

OPERATION MANUAL

TH3311/TH3312/TH3321/TH3331

Digital Power Meter

Tonghui Electronic Co.,Ltd.

www.tonghui.com.cn

Contents

Chapter 1 Introduction	1
1.1 Introduction to Instrument.....	1
1.2 Unpacking	2
1.3 Power Connection	2
1.4 Fuse.....	3
1.5 Environment	3
1.6 Warm-up.....	3
1.7 Other Features	3
Chapter 2 Introduction to Front and Rear Panels.....	4
2.1 Introduction to Front Panel.....	4
2.2 Introduction to Rear Panel.....	5
Chapter 3 Basic Operation	7
3.1 Starting Up	7
3.2 Display zone	8
3.3 Display interface switch	8
3.3.1 DISP key.....	8
3.3.2 SETUP key	9
Chapter 4 Basic Interface Display & Parameter Settings	10
4.1 <MEAS DISP> Interface.....	10
4.1.1 Test mode	11
4.1.2 Test range	12
4.1.3 Measurement parameters.....	13
4.1.4 HOLD key (lock the measurement result).....	14
4.1.5 Energy integral key.....	14
4.1.6 SYNC key (Synchronized sampling)	15
4.2 <COMP DISP> Interface	15

4.2.1 CompON	15
4.2.2 Sound.....	16
4.2.3 Main display area	16
4.2.4 Handle parameter selection	16
4.2.5 Compare output description	17
4.3 <BIN DISP> Interface.....	18
4.3.1 Bin parameters.....	18
4.3.2 Bin Mode.....	19
4.3.3 Sound.....	19
4.3.4 Bin ON	20
4.3.5 Load Bin.....	20
4.3.6 Main display area	20
4.4 <HARM DISP> Interface.....	20
4.4.1 HARM Common Display.....	22
4.4.2 HARM List Display	23
4.4.3 HARM Bar Display.....	24
4.5 <WAVE DISP> Interface.....	24
4.5.1 Waveform display description.....	25
4.5.2 Waveform display with harmonics.....	26
4.6 <MEAS SETUP> Interface	26
4.6.1 MODE	27
4.6.2 TRIG.....	27
4.6.3 DELAY	27
4.6.4 SYNC	28
4.6.5 LineFilt.....	28
4.6.6 Range.....	29
4.6.7 AVG	29
4.6.8 EMode.....	29
4.6.9 E_Time	30
4.7 <COMP SETUP> Interface.....	30

4.7.1 Handle Parameters Setup.....	30
4.7.2 Compare Limit Setup	31
4.7.3 Independent comparison switch	31
4.8 <BIN SETUP> Interface	32
4.8.1BIN parameter selection	33
4.8.2 Data Mode	33
4.8.3 Nom	33
4.8.4 BIN Limit Settings	33
4.9 <HARM SETUP> Interface	34
4.9.1 HarmON	34
4.9.2 HarmItem.....	35
4.9.3 HarmForm	35
4.9.4 CalStd	35
4.9.5 DataMode	36
4.10 <Handle SETUP> Interface.....	36

Chapter 5 System Setup and File Manage37

5.1 System Setup	37
5.1.1 Key Sound	37
5.1.2 Language	37
5.1.3 Password.....	38
5.1.4 Bus Mode	38
5.1.5 Baud Rate	38
5.1.6 485 Addr.....	39
5.1.7 Setting Time and Date	39
5.1.8 Command mode setting	40
5.2 <File Manage>	40
5.2.1 File Management Function Interface.....	40
5.2.2 Introduction to Save/Recall	41
5.2.3 Structure of File Folder/File in a U Disk.....	42
5.2.4 File Management Operation Procedure	43

5.2.5 Data Save Settings	45
5.3 System Tools	46
5.3.1 System Reset	46
5.3.2 Default Set	46
5.3.3 Update	46
5.3.4 DPS Version	47
Chapter 6 Correct Measurement	48
6.1 Wiring method.....	48
6.1.1 Internal connection of current terminal	48
6.1.2 External connection of current terminal	48
Chapter 7 Basic Principles and Technical Specifications	50
7.1 Basic principles	50
7.1.1 Measurement parameters and symbols.....	51
7.1.2 Calculation formula	51
7.1.3 Hardware range	53
7.2 Instrument parameter.....	53
7.2.1 Overview of overall parameters	53
7.2.2 Specific input indicators	54
7.3 Precision index	55
7.3.1 Voltage test accuracy.....	55
7.3.2 Current test accuracy	55
7.3.3 Test accuracy for other parameters.....	56
Chapter 8 Remote Control.....	58
8.1 RS232C Connection	58
8.1.1 SCPI (Standard Commands for Programmable Instruments).....	59
8.1.2 ModeBus Command Protocol	59
8.2 RS485 Interface Description	59
8.2.1 RS485 address	59
8.3 USBTMC Remote Control System	60

8.3.1 System Configuration.....	60
8.3.2 Install the Driver.....	60
8.4 USBCDC Virtual Serial Port.....	61
Chapter 9 SCIP Command Reference.....	62
9.1 IEEE488.2 Common Command.....	63
9.1.1 *IDN?	63
9.1.2 *TRG	63
9.1.3 *RST.....	63
9.1.4 *CLS.....	64
9.1.5 *ESE.....	64
9.1.6 *ESR.....	64
9.1.7 *OPC	64
9.1.8 *SRE?.....	65
9.1.9 *STB?.....	65
9.2 SCPI Commands	65
9.2.1 DISPlay Subsystem Commands	65
9.2.2 FUNcTION Subsystem Commands.....	66
9.2.3 COMPare Subsystem Commands	69
9.2.4 BINset Subsystem Commands	70
9.2.5 HARMonic Subsystem Commands.....	72
9.2.6 WAVE Subsystem Commands.....	73
9.2.7 SYSTem Subsystem Commands	74
9.2.8 MEMory Subsystem Commands.....	75
9.2.9 TRIGger Subsystem Commands	75
9.2.10 FETCh Subsystem Commands	76
9.2.11 HANDle Subsystem Commands	78
9.3 ModeBus commands	79
9.3.1 Command format.....	79
9.3.2 CRC16 calculation method - look-up table method	80
9.3.3 Command function comparison table.....	82

Chapter 10 Handler Interface	87
10.1 Port definitions	87
10.2 Specific description of the port.....	87
10.3 HANDLER Timing Diagram	88
10.4 Introduction to HANDLE SETUP.....	88

Declaration

The descriptions contained in this manual may not cover all information about this instrument. Introductions to the improvements of the instrument in performance, function, internal structure, outer appearance, accessories, packing material, etc. are subject to change without notice. If you find any inconformity of this manual with our instruments, please contact us for further consultation by the address listed on the cover.

Chapter 1 Introduction

Thank you for your purchase and use of our products! This chapter will introduce the basic instrument performance, which is followed by notes of unpacking and installing.

1.1 Introduction to Instrument

TH33XX series single-phase digital power analyzer (digital power meter) uses high-speed 32-bit processor and professional DSP digital signal processor. With fast speed, wide frequency bandwidth, complete function, compact structure, stable test, simple operation and good human-machine interface, it is a new generation of digital power analyzer and the main parameters that can be measured are: voltage and current RMS, voltage and current AC component, voltage and current DC component, active power, reactive power, apparent power, energy timing, power factor, frequency, voltage and current peak factor, voltage and current peak-to-peak value. Depending on the instrument model, some models do not have harmonic analysis function.

The contents of this manual cover the TH3311/TH3312/TH3321/TH3331 four instruments (the common points of the four instruments indicated by TH33XX in the below introduction and the specific models are marked when having different points), all of which belong to the single-phase power analyzer. The advantages of the input bandwidth (45~400Hz) cover most of the power supply on the market. In addition to the basic electrical parameter measurements, the four instruments also provide a comparatively intuitive input waveform display as well as the HANDLER interface, RS232C/ RS485 interface and USBTMC, USB CDC interface, supplying conditions for the instrument to be used for automatic sorting system and computer remote operation; the difference between different models is mainly in the current measurement range and whether it has harmonic analysis function. The maximum test current is 40A with stable accuracy. The specific difference can be seen in the following instrument model comparison table.

The main features of the instrument:

- 4.3 inch LCD display;
- Soft power switch;
- Chinese and English optional operation interface;
- Input frequency range (45~400Hz);
- Range automatic / manual is controllable;
- The maximum test current is 40A (depending on the model), and the minimum current can be up to 1uA (depending on the model);
- Controllable synchronous trigger source;
- Provide 5kHz line filter switch;
- Flexible energy integration control;
- Parameter comparison and Handle controllable output function;
- Parameter file selection function;
- Harmonic analysis function (related to the specific model);

- Waveform display function;
- Support U disk file storage, upgrade the instrument program through U disk;
- Serial interface: RS-232C/RS485 and USB virtual serial port provide great convenience for serial communication between instruments and peripherals. Peripherals can set various functions and parameters of the instrument through this interface, which can basically replace the function of the panel keyboard; the interface commands are uniformly written using the internationally-used programmable instrument standard command (SCPI) format, which greatly facilitates user programming.
- HANDLE interface: This interface synchronizes the instrument with the mechanical processing equipment of the component and detects the sorting component, and outputs the bin result to the mechanical processing device.

1.2 Unpacking

Inspect the shipping container for damage after unpacking it. It is not recommended to power on the instrument in the case of a damage container.

If the contents in the container do not conform to the packing list, notify us or your dealer.

The instrument model and basic functions are compared as shown in Table 1-1 below:

Model	Difference and function description
TH3311	Conventional, 600V/20A, without harmonic analysis function
TH3312	Conventional, 600V/20A, with harmonic analysis function
TH3321	Micro current type, 600V/2A, with harmonic analysis function
TH3331	Large current type, 600V/40A, with harmonic analysis function

Table 1-1 Instrument model and basic function comparison table

Note: It is best to keep the packing box of the instrument after unpacking, so as to avoid unnecessary damage to the instrument during the transportation process due to the unsuitable packing.

1.3 Power Connection

- 1) Power supply: 200~240VAC
- 2) Power supply frequencies: 47~63Hz
- 3) Power supply power range: $\leq 30\text{VA}$
- 4) L (line wire), N (neutral wire) and E (earth ground wire) of the power supply input socket should correspond to the power plug of the instrument.
- 5) The instrument has been specially designed for decreasing noise jamming caused by the input in AC power terminal, but it is also recommended to use it in the environment of low noise. If noises cannot be avoided, install a power source filter please.

WARNING: To avoid injury to personnel and damage to the instrument resulting from electric shock, do sure that the earth ground wire is safely grounded.

1.4 Fuse

The fuse is a standard configuration, so use the included custom fuse please.

1.5 Environment

- Normal working temperature: 0 °C to 40 °C, humidity: 20~80%RH
- Reference operating temperature: 20 °C ± 8 °C, humidity: < 80% RH
- Transportation environment temperature: 0 °C~55°C, humidity: ≤93%RH
- Do not store or use the instrument where it could be exposed to many dusts, great vibration, direct sunshine and corrosive gas.
- For high accuracy, do not block the left air vent so as to ensure good ventilation.
- The instrument has been specially designed for decreasing noise jamming caused by the AC power input, but it is also recommended to use it in the environment of low noise. If noise cannot be avoided, install a power filter please.
- If the instrument is not used for a long time, please store it in the original box or similar box in a ventilated room with a temperature of 5 °C ~ 40 °C and a relative humidity of not more than 85%RH. The air should not contain corrosive harmful impurities and should avoid direct sunlight.

1.6 Warm-up

- 1) For accurate measurement, the warm-up time should not be less than 30 minutes.
- 2) Do not turn on or off the instrument frequently. This may cause internal data confusion.

1.7 Other Features

- 1) Consumption: ≤16VA
- 2) Machine dimension (W*H*D): 215mm*88mm*335mm;
- 3) Outline dimension (W*H*D): 235mm*105mm*360mm;
This dimension is the final packaging size.
- 4) Weight: Approx. 3.85kg

Chapter 2 Introduction to Front and Rear Panels

This chapter will describe the basic operation of TH33XX. Before using the instrument, please read this chapter carefully.

2.1 Introduction to Front Panel

Figure 2-1 shows the front panel of TH33XX.

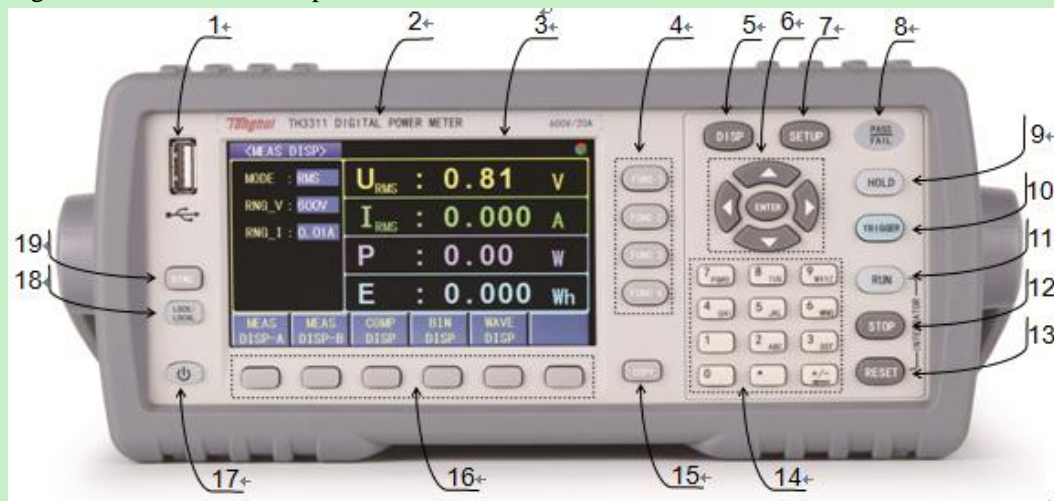

Figure 2-1 Front Panel

1) USB HOST

HOST interface of USB for USB storage and upgrade

2) Trademark and Model

Show instrument trademark and model

3) LCD and touch screen

480*272dot matrix LCD screen for human-computer interaction display

4) FUNC key

Modify the measurement parameters of the corresponding position, only applicable to the measurement display A page

5) [DISP]

Press [DISP] to enter into the MEAS DISP page

6) Universal Arrow Keys

Up, down, left and right direction buttons and confirmation button

7) SETUP key

Used to enter the MEAS SETUP page and quickly switch to the SYSTEM SETUP page.

8) PASS/FAIL display

In BIN DISP or COMP DISP interface, the result of the comparison will be displayed by PASS/FAIL.

9) HOLD

It is the measurement result hold button. Press the key in the measurement display page to hold/release the current result lock, and has an LED indication, which is suitable for the measurement display A/B page.

10) [TRIGGER]

When the trigger mode is manual (MAN) mode, press this button once to perform a trigger measurement, which is only applicable to each test page.

11) RUN

Energy integration start button, the red LED light is on during the energy integration operation, and the LED is not on when the timing is stopped, which is suitable for the measurement display A/B page.

12) STOP

Energy integration stop button, “Run LED” does not light after energy integration stops, which is suitable for the measurement display A/B page.

13) RESET

Energy integral reset button, after the integral timing stops, press RESET to make zero, which is only applicable to the measurement display A/B page.

14) English and numeric keys

Input the English characters and numbers

15) COPY

Press this button to capture the current interface to the PIC folder of the U disk.

16) Soft key area

After the direction key moves the cursor position, the soft key area corresponds to different functions, press to modify the corresponding parameter value.

17) POWER

The power switch is green when the instrument is turned on and the button is red when the power is off.

18) LOCK

Press LOCK key once, the button enters the locked state and has the LED indication, press the key again, the button is unlocked.

19) SYNC

Switching the sync source button, that is, the fast switching function of the sync source and the sync instrument power, which is only applicable to each measurement display page.

2.2 Introduction to Rear Panel

Figure 2-2 shows the rear panel of TH33XX.

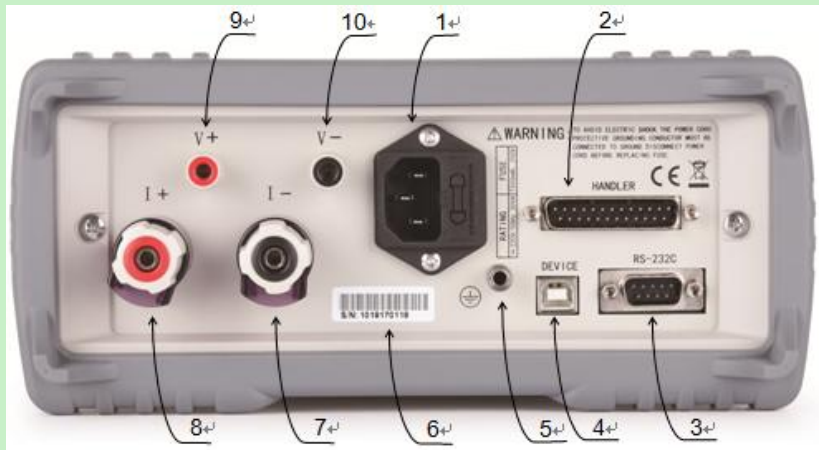

Figure 2-2 Rear Panel

1) Power Socket

It is used to input AC power.

2) HANDLER Interface

Through HANDLER interface, an automatic test system can be conveniently constructed to realize auto test. The instrument outputs the comparison result signal and contact signal through the interface, and at the same time obtains a "start" signal. It is only available for compare display pages.

3) RS232C/485 Interface

It realizes serial communication of the instrument with PC.

4) USB Device

The computer can communicate with TH33XX series instruments through the USB DEVICE interface.

5) Ground Terminal

This terminal connects the instrument chassis thus to protect or shield ground connection.

6) Label

Indicate the specific S/N number of the instrument.

7) Current measurement input terminal negative terminal (I-)

8) Current measurement input terminal positive terminal (I+)

9) Voltage measurement input terminal positive terminal (V+)

10) Voltage measurement input terminal negative terminal (V-)

Chapter 3 Basic Operation

The basic operation steps for TH33XX:

- 1) Use [DISP], [SETUP] and soft keys to enter into the page required to display.
- 2) Use arrow buttons ([←] [↑] [→] [↓]) to move the cursor to desired zone and the corresponding area will change to the cursor color (blue).
- 3) The soft key function corresponding to the parameter of the current cursor area will be displayed in the “soft key area”. Use the common soft keys below the LCD to perform the corresponding operation or press the ENTER key to quickly cycle through the enumerated state of the selected parameters (for some numeric input parameters, when pressing this confirmation button, there will be input information prompt, indicating that the value can be entered by the numeric keys).

3.1 Starting Up

Ensure the power earth (ground) wire is grounded, plug into a 3-wire power socket. Press down the power switch on the bottom left corner of the front panel, the instrument will be started up and a boot screen will be displayed.

Figure 3-1 shows the boot screen of TH33XX, indicating product information such as instrument trademark, model and version.



Figure 3-1 Boot screen

If the password protection is enabled, you will be asked to input your password. After inputting your password, press [ENTER] to enter into the main menu page.

NOTE: This series of products have enabled password protection and the default password is 33XX (the model of the instrument, such as 3311). You can reset the password by yourself. Refer to the password function on <SYSTEM SETUP> page for more details.

3.2 Display zone

TH33XX adopts 24-bit 4.3-inch color LCD screen with a resolution of 480*272. The display screen is divided into the following zones, as shown in figure 3-2.

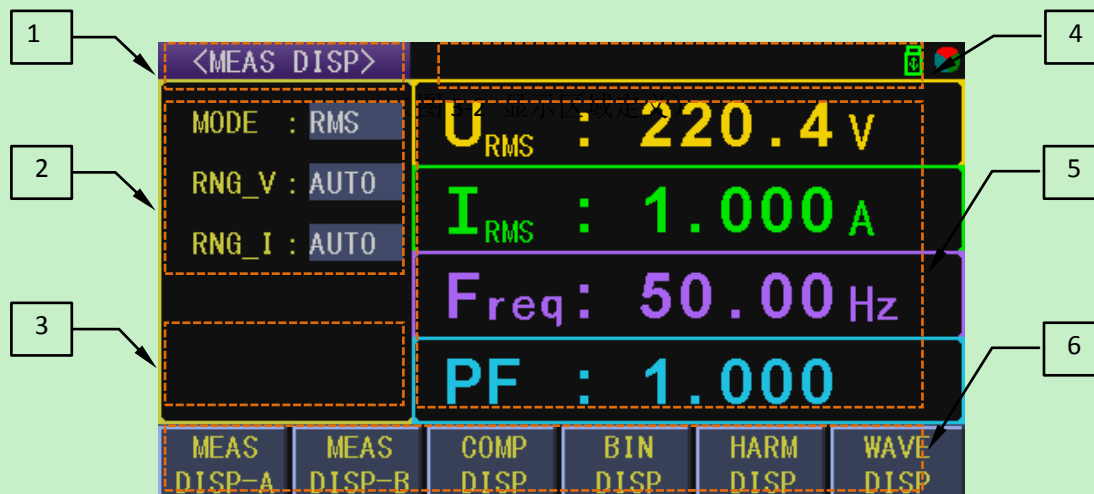

Figure 3-2 Display zone

1	Main menu area	This zone shows the current page name.
2	Test Condition Area	This area is used to display and quickly modify the test common conditions.
3	Message Prompt Area	This area is used to display various prompts during the test and setup process.
4	Icon prompt area	This area is used to display the U disk, keyboard lock and test speed icon indication.
5	Measurement result display area	This area displays the test parameter results. The current page can be set to different measurement parameters in 4 windows.
6	Soft Key Area	This area is used to display the function menu corresponding to the cursor area.

Table 3-1 Explanation of each area

Remarks: Due to the different layouts of different pages, the display information of different pages (2, 3 and 5) is not necessarily the same, and is only for comparison reference.

3.3 Display interface switch

The DISP key and the SETUP key are the two most frequently used keys in the page switching process, which are the entrances to the test related pages and the setting related pages.

3.3.1 DISP key

Press the DISP key to enter the measurement display home page (the measurement display A page). The function page menu corresponding to the soft key area is as follows:

MEAS DISP A	----<MEAS DISP A>
MEAS DISP B	----< MEAS DISP B>
COMP DISP	----<COMP DISP>
BIN DISP	----<BIN DISP>
HARM DISP	----<HARM DISP>
WAVE DISP	----<WAVE DISP>

Note: 1. According to the instrument model, some models have no harmonic function (refer to the instrument model comparison for details).

2. If entering the measurement setting page in the measurement display B page, press the DISP key, the page will first return to the measurement display B page. If necessary, you can press the DISP key again to return to the measurement display A page. At this time, the function of the soft key menu is optional.

3.3.2 SETUP key

Press the SETUP key to enter the measurement setup page. The function page menu corresponding to the soft key area is as follows:

MEAS SETUP	----<MEAS SETUP>
COMP SETUP	----<COMP SETUP>
BIN SETUP	----<BIN SETUP>
HARM SETUP	----<HARM SETUP>
HANDLE SETUP	----<HANDLE SETIP>
SYSTEM SETUP	----<SYSTEM SETUP>

Note: 1. According to the instrument model, some models have no harmonic function (refer to the instrument model comparison for details).

2. Under the SYSTEM SETUP page, press the arrow keys to move the cursor to the **FILE**. At this time, **INTER File** and **EXTER File** will be displayed in the soft key area. Press **INTER File** to enter the internal file management page and press **EXTER File** to enter the external file management page. The condition of entering the external file management page is that the external U disk is inserted and available, and the formatting of the U disk is limited. For details, see the file management chapter.

Chapter 4 Basic Interface Display & Parameter

Settings

The conventional setting method of TH33XX series instruments is as follows:

- 1) Use the arrow keys to move the cursor to the position of the parameter to be modified;
- 2) For the enumerated parameters, according to the function prompts of the six soft keys, press the corresponding soft key to complete the modification of the parameter value or press the ENTER key to cyclically modify the enumerated parameter value;
- 3) For numeric parameter values,
 - a. According to the function prompts of the six soft keys, press the corresponding soft key to achieve fine adjustment (increase or decrease) of the logarithmic value;
 - b. You can also input the value you want to set accurately through the numeric keypad. After the numeric key is input, you need to select the appropriate order magnitude according to the soft key function prompt or press ENTER to confirm quickly.

Note: The parameter setting of the measurement display page is only to provide the user with a quick setting entrance, and the measurement setting interface is a more comprehensive setting.

4.1 <MEAS DISP> Interface

Press DISP, the <MEAS DISP> page will be displayed in the screen shown as figure 4-1. The measurement display page is divided into two modes: classic mode display (A) and full-screen parameter mode display (B), which are defined as A and B display styles; the style switching method can be seen in the software zone function prompt.

<Measurement display A> belongs to the traditional measurement display style. The visible measurement parameters can be modified by the function keys on the right side of the display; <Measurement display B> belongs to the full parameter display style, making full use of the display resources of the LCD to show more measurement parameters. The user is free to choose according to the usage habits.

<Measurement display A> as shown in Figure 4-1, <Measurement display B> is shown in Figure 4-2:

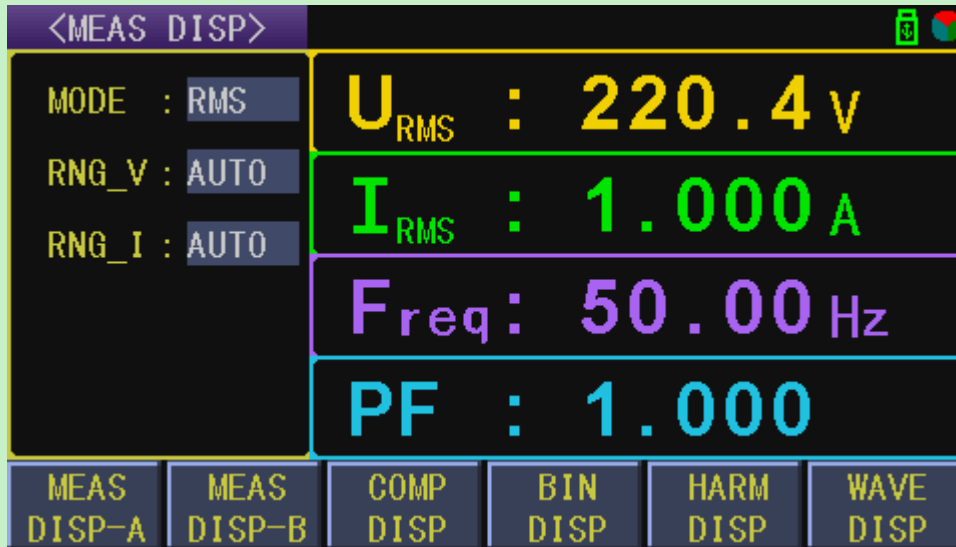

Figure 4-1 Measure Display A



Figure 4-2 Measure Display B

(Note: if you want to return to the measurement display B after entering the measurement display B, due to the different function of the soft key area , you need to press the DISP key to return to the measurement display A page;

In addition, if you enter the setting page under the measurement display B page, when you press DISP again, in order to give the user convenience, you will return to the measurement display B page first, and then press the DISP button again to return to the measurement display A page.)

4.1.1 Test mode

There are three measurement modes for TH33XX: True RMS measurement mode (RMS), AC measurement mode (AC), DC measurement mode (DC), and factory default setting: True RMS mode (RMS).

The main difference between the test mode selection is voltage and current, that is, the voltage and current values (U_{rms} & I_{rms} , U_{ac} & I_{ac} , U_{dc} & I_{dc}) in the three modes respectively represent the

true RMS value, the AC component size, and the DC component size of the input signal; The other parameters do not distinguish the measurement mode, which are the calculation results of the displayed true RMS value data (whether in RMS mode, AC mode or DC mode). For example, power (P) refers to active power.

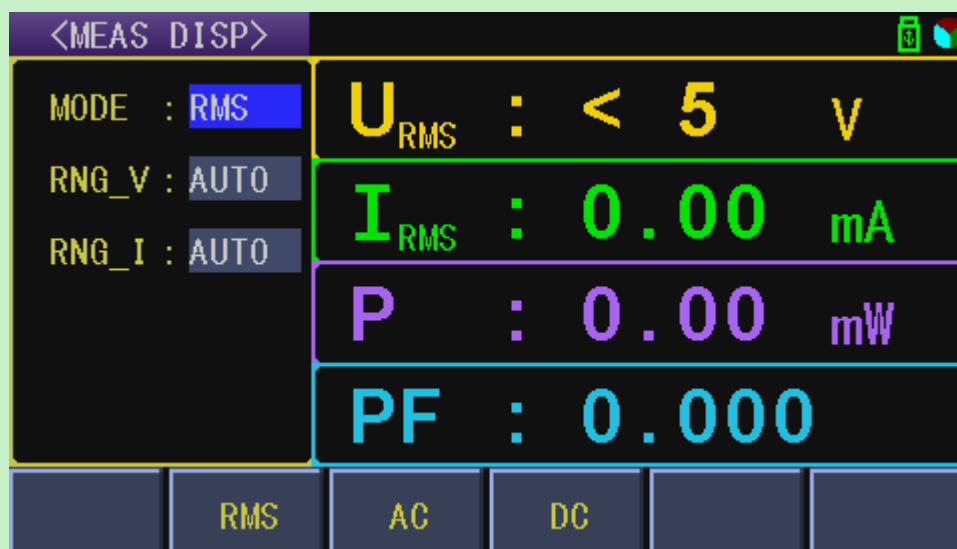

Figure 4-3 Setting measurement mode in Measurement display interface

Note: As shown in Figure 4-3 below, after the cursor moves to the corresponding parameter, parameter function and selection operation of the corresponding soft key area are only compared on this page, and other pages are basically the same as this operation, so for the modification of other page parameter values, please refer to the screenshot description here.

Setup steps:

- 1) Move the cursor to the MODE area, and the following soft keys are displayed in the soft key area of the screen, as shown in Figure 4-3.
 - RMS: true rms measurement mode
 - AC: AC measurement mode
 - DC: DC measurement mode
- 2) Press the corresponding soft key or press the ENTER key to complete the corresponding settings.

Note: Under the measurement display B page, the setting mode can be directly based on the soft key function prompt.

4.1.2 Test range

TH33xx has 4 voltage test ranges: 75V, 150V, 300V, 600V;

TH331x has 7 current test ranges: 10mA, 30mA, 100mA, 400mA, 1.5A, 5A, 20A;

TH332x has 7 current test ranges: 1mA, 3mA, 10mA, 40mA, 150mA, 500mA, 2A;

TH333x has 8 current test ranges: 10mA, 30mA, 100mA, 400mA, 1A, 3A, 10A, 40A;

Factory default settings:

The voltage is at the maximum voltage range (600V);

The current is in the maximum current range (2A/20A/40A), corresponding to the instrument model;

Setup steps:

1) Move the cursor to the RNG V/I area, and the following soft keys are displayed in the soft key area of the screen.

- AUTO: Used to set the range to automatic mode
- HOLD: For quick viewing of the current range, the range switches from automatic mode to hold mode.
- ↓ (-) : Used to select a small range downward
- ↑ (+) : Used to select a large range upward

2) Press the corresponding soft key or press the ENTER key to complete the corresponding settings.

Note: Under the measurement display B page, the setting mode can be directly based on the soft key function prompt.

4.1.3 Measurement parameters

The measurement parameter settings under the measurement display A page (displaying 4 measurement parameters)

Factory default settings: voltage (U), current (I), power (P), power factor (PF);

Setup steps:

1) Press the function key FUNC 1/2/3/4 corresponding to the 4 parameters directly on the current page;

(Note: The four function keys on the right side of the screen are only valid here.)

The options that can be set for each parameter are as follows:

FUN1 can set the displayed parameters (voltage, current, active power, power factor, frequency, voltage peak factor, voltage positive peak and voltage negative peak)

FUN2 can set the displayed parameters (voltage, current, active power, current peak factor, current positive peak and current negative peak)

FUN3 can set the displayed parameters (voltage, current, active power, power factor and frequency)

FUN4 can set the displayed parameters (voltage, current, active power, power factor, frequency, total power, virtual power and energy)

Note: The voltage and current in the above parameters are based on the measurement mode, that is, the measurement mode is different, the physical meaning of the voltage and current is different, of course, there is a subscript prompt; in addition, when the measurement mode is DC (DC), the displayed four measurement parameters will be fixed to (voltage, current, power, energy) and cannot be modified.

The physical meanings of the specific measurement mode and corresponding setting parameters are shown in Table 4-1:

Measurement mode	Setup parameter	Physical meaning
RMS	U/I	Voltage and current true RMS
AC	U/I	Voltage and current AC component
DC	U/I	Voltage and current DC component
RMS/AC/DC	P	Active power
RMS/AC	PF	Power Factor
RMS/AC	F	Frequency
RMS/AC	CFu/CFi	Voltage and current peak factor
RMS/AC	VA/VAR	Total work/virtual work
RMS/AC/DC	E	Active power versus time

Table 4-1 Physical meaning of the measurement mode and corresponding setting parameters

4.1.4 HOLD key (lock the measurement result)

In the continuous test process, press this key to capture the current test result and make the test result locked. It facilitates the user to capture the instantaneous test result.

Setup steps: lock each time when you press once;

Note: This button is only valid under the measurement display A/B page.

4.1.5 Energy integral key

Mainly related to the (start, stop, reset button settings) of the energy integral (statistics)

Setup steps:

- 1) First, you need to confirm that the integral control mode (integration mode) and energy timing have been set on the measurement setup page (for detailed settings, see the measurement setup page).
- 2) The following three energy control related buttons can be seen on the front panel.
 - RUN button: used to start the energy integration (statistics) function;
 - STOP button: used to stop the energy integration (statistics) function;
 - RESET button: After the energy integration function stops, press the reset button to reset the integral timing and accumulated energy. If the energy integration is stopped, if you do not press the RESET button to reset the integral timing and accumulated energy, press the RUN button directly, the last clock count and accumulated energy will be counted to continuously perform energy statistics;

(Note: These 3 keys are only valid under the measurement display A/B page. If the RUN key is pressed, there is no action after the corresponding RUN red light flashes once, indicating that the integration time is over, and you need to try again after pressing the RESET key to reset the energy integration and timing clock.

If the non-measurement display A/B page is entered during the running of the integral function, the integral operation will enter the pause state, and will continue to run when it returns to the measurement display A/B page again.

4.1.6 SYNC key (Synchronized sampling)

Used for fast switching source synchronization (automatic synchronization) and line power synchronization, only valid on each test page;

Setup steps:

Press once to switch (switch between auto and power);

For instructions and suggestions on using the synchronization function, see the Synchronization Signals section of the <Measurement Settings> page.

4.2 <COMP DISP> Interface

Press <DISP> and select the **COMP DISP** soft key to enter into the <COMP DISP> page shown as figure 4-5.

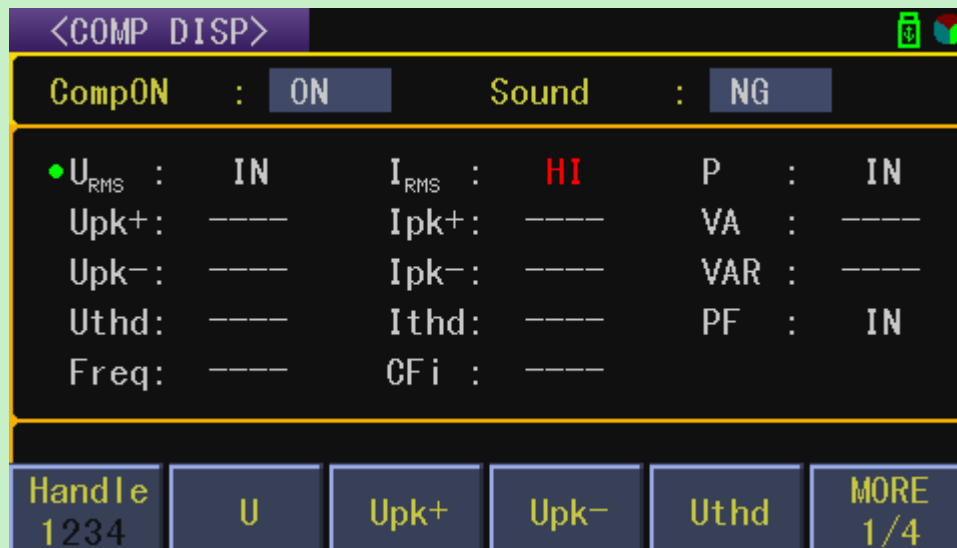

Figure 4-5 Compare display interface

There are 14 (or 12) comparable parameters (U, Upk+, Upk-, Uthd, I, Ipk+, Ipk-, Ithd, P, VA, VAR, PF, Freq, CFi).

Note: The instrument without harmonic analysis function has only 12 parameters, no (Uthd and Ithd);

For instruments with harmonic analysis, the prerequisite for effective comparison of Uthd or Ithd is that the harmonic analysis switch is turned on (see the Harmonic Switch section of the <Harmonic Setup> page for the opening method).

4.2.1 CompON

It is used to control the total switch status of the compare function; the factory default setting is ON (ON).

Setup steps:

1) Move the cursor to the CompON area, and the following soft keys are displayed in the soft key

area of the screen.

- OFF: used to turn off the comparison function
- ON: used to turn on the comparison function

2) Press the corresponding soft key or press the ENTER key to complete the corresponding settings.

Function description: Only when the comparison function main switch is turned on, the independent switch of each comparison parameter is valid.

4.2.2 Sound

It is used to set the sound output mode of the comparison result; the factory default setting is bad (NG).

Setup steps:

1) Move the cursor to the Sound area, and the following soft keys are displayed in the soft key area of the screen.

- (NG): used to generate a sound when the comparison result is bad
- (GD): used to generate a sound when the comparison result is good
- OFF: used to turn off the output function of the comparison sound

2) Press the corresponding soft key or press the ENTER key to complete the corresponding settings.

Product comparison judgment description:

- NG is a unqualified product, and the judgment condition is that one or more of the comparison results of all the parameters participating in the comparison are unqualified;
- GD is a qualified product, and the judgment condition is that all the comparison parameters are qualified.

4.2.3 Main display area

The main display area is used to display comparison parameters and comparison results.

Display instructions:

- Red (HI/LO): indicates that the comparison result is too high or too low;
- White (IN): indicates qualified;
- “---”: indicates that the parameter does not enable the comparison function (the comparison independent switch of any parameter can be set on the comparison setting page);

Note: The middle strip area of the main display area and the soft key area is used as the default human-computer interaction information prompt area.

4.2.4 Handle parameter selection

Since TH33XX series provides four external Handle output ports on the rear panel, the comparison result of the four parameters can be selected in the comparison parameter to control the output of the corresponding four Handle ports.

The default parameters of the four channels are the voltage (U), current (I), power (P), and power factor (PF). The parameters that can be set are shown in Figure 4-5 of the <COMP DISP> page.

Setup steps:

- 1) Move the cursor in the COMP DISP area (that is, at the initial position of the page), and the screen soft key area is displayed as shown in Figure 4-5.
- 2) Press the first soft key Handle [1/2/3/4] on the left to confirm the current Handle channel that needs to be set. When selecting, observe the main display area. If there is green dot before the comparison parameter, it is the parameter that has been set for the channel;
- 3) Observe the soft key area function prompt, select the parameter that needs to control the output or press ENTER key to select;

Note: U and I in the above parameters have subscripts, indicating the current parameter measurement mode (ie RMS/AC/DC), which indicates that the comparison values of U and I are related to the current measurement mode, and data of other parameters are under the calculation of the effective value. In addition, according to the specific model of the instrument, TH3311 does not have the harmonic analysis function, so there is no voltage total harmonic (U_{thd}) and current total harmonic (I_{thd}) listed above.

4.2.5 Compare output description

The specific Handle output state control is described in the Handle Interface Description section.

Qualified and unqualified judgment description:

- One or more of the comparison results in the parameters participating in the comparison are unqualified, that is, the overall comparison result is unqualified;
- The comparison results in the parameters participating in the comparison are all qualified, that is, the overall comparison result is qualified;

When the comparison switch is ON (determined based on the result of the comparison parameter):

1) PASS/FAIL lamp output status

- The comparison result is unqualified, and the red FAIL light is on;
- The comparison result is qualified, and the green PASS light is on;

2) Buzzer output status

- The comparison result is unqualified. If the “Sound” is selected as “GD” at this time, it means that when all the comparison results are qualified, it will have the corresponding signal output, and this is the unqualified state (the buzzer will not beep); If “NG” is selected at this time, it means that if there is a failure, there will be a corresponding input, and this is the unqualified state (the buzzer is in long beep);
- The comparison result is qualified. If the “Sound” is selected as “GD” at this time, it means that when all the comparison results are qualified, it will have the corresponding output, and this is the qualified state (the buzzer is in short beep); If “NG” is selected at this time, it means that if there is a failure, there will be a corresponding output, and at this is a qualified state (the buzzer will not beep);

Note: If “Sound” selects “OFF”, the buzzer has no output response;

When the comparison switch is OFF:

All parameter comparison functions are turned off, the PASS light and FAIL are not lit, the buzzer will not beep, and the Handle port is also in the reset state.

Note: When the sound judgment condition is satisfied, the measurement speed will decrease due to waiting for the buzzer sound time.

4.3 <BIN DISP> Interface

Press <DISP> and select the **BIN DISP** soft key to enter into the <BIN DISP> page shown as figure 4-6 and 4-7.



Figure 4-6 Bin mode in Bin display



Figure 4-7 Compare mode in Bin display

4.3.1 Bin parameters

The bin parameters can be set on the current page or on the <BIN SETUP> page (see the bin settings page for details).

The parameters that can be set are shown in Figure 4-5 of the <COMP DISP> page and their

introduction.

Setup steps:

- 1) Move the cursor to the BIN DISP area (in the initial position), and the screen soft key area is displayed as shown in Figure 4-6.
- 2) Observe the soft key area function prompt, select the parameter that needs to control output or press ENTER key to select;

Remarks: The bin function belongs to the refinement function of the comparison function. The comparison item (bin parameters) of the bin comparison is derived from one of the comparison parameters of the comparison page, so there is difference between with and without harmonic, available with or without voltage and current total harmonic distortion.

4.3.2 Bin Mode

It is used to select the mode of bin sorting. The factory default setting is Bin mode.

Setup steps:

- 1) Move the cursor to the Bin mode area, and the following soft keys are displayed in the soft key area of the screen.

- **COMPARE:** that is, whether the comparison is qualified under the specified bin;
- **BIN:** Sort the selected parameters, that is, sort out the tested products, a total of 6 bins can be set to participate in the selection;

- 2) Press the corresponding soft key or press the ENTER key to complete the corresponding settings.

Note: The bin sorting does not involve Handle output control, only with sound output and LED output.

4.3.3 Sound

It is used to set the buzzer output bin No. corresponding to the bin result. The factory default setting is NG.

Setup steps:

- 1) Move the cursor to the Sound area, and the following soft keys are displayed in the soft key area of the screen.

- **NG:** It is used when the bin result is unqualified.
- **GD:** It is used when the bin result is qualified.
- **OFF:** It is used to turn off the bin beep function.

- 2) Press the corresponding soft key or press the ENTER key to complete the corresponding settings.

Product selection decision description:

- NG is unqualified product and the judgment condition is that the bin parameter comparison is unqualified in Compare mode or does not find a suitable bin in Bin mode;
- GD is qualified product and the judgment condition is that the bin parameter comparison is qualified in Compare mode or finding a suitable bin in Bin mode.

4.3.4 Bin ON

It is used to control the switch state of the bin sorting function and the factory default setting is ON.

Setup steps:

1) Move the cursor to the Bin ON area, and the following soft keys are displayed in the soft key area of the screen.

- **OFF**: Used to turn off the bin function
- **ON**: Used to turn on the bin function

2) Press the corresponding soft key or press the ENTER key to complete the corresponding settings.

4.3.5 Load Bin

It is used to load the specified bin comparison range in Compare mode. The factory default setting is BIN1.

Setup steps:

1) Move the cursor to the Load BIN area, and the following soft keys are displayed in the soft key area of the screen.

- **Increase +**: used to increase the bin number
- **Decrease -**: used to decrease the bin number

2) Press the corresponding soft key or press the ENTER key to complete the corresponding settings.

4.3.6 Main display area

In the Compare mode, the comparison result (HI/LO/IN/ ----) of the selection parameter in the fixed bin is displayed, correspondingly, "higher/lower/moderate/not compared", and the current measurement result is displayed below. The reason for not comparing is that the upper and lower limits of the corresponding parameter are not set or the Bin ON is not turned on;

In the Bin mode, the bin number (BIN1~6 or OUT) of the bin parameter is displayed. The judge and comparison rule of the bin number is searching from the BIN 1 to BIN 6. When finding a bin, it will not continue to search. It shows that the comparison range of BIN1 to BIN 6 is theoretically included, that is, the range of BIN 1 should be the finest; at the same time, the measurement result of the current BIN parameter is shown below, as shown in the figure: U_{RMS} : 220.2V.

Note: The middle strip area of the main display area and the soft key area is used as the default human-computer interaction information prompt area.

4.4 <HARM DISP> Interface

Press <DISP> and select the **HARM DISP** soft key to enter into the <HARM DISP> page. The harmonic display is divided into three display modes, namely, common display, list display and

bar graph display, and the factory default setting is list display; the display form can be modified by pressing the SHOW FORM in soft key area on the <HARM DISP> page and then change the corresponding display form, or you can move the cursor to the SHOW FORM area on the <HARM SETUP> page and press the corresponding soft key to modify. The three display forms are shown in Figure 4-8, Figure 4-9 and Figure 4-10:

Harmonic analysis function introduction: Using the phase-locked loop circuit to synchronize with the fundamental frequency, analyze the harmonic distortion of the power frequency signal (50/60Hz) voltage or current, and provide two commonly used harmonic distortion calculation standards, namely IEC and CSA; the maximum number of analyses reaches 50 harmonics; the harmonic display refresh rate is about 2 times/second. For the non-power frequency signal, TH33XX series instruments do not mention the accuracy index. If you want to check the relevant harmonic state, you should first turn off the line filter in the measurement setting page.

Note: Some models such as TH3311 has no harmonic analysis function, so users can ignore this chapter.

● **HARM ON/OFF**

The factory default is ON, you can choose to switch the harmonic analysis function: ON/OFF;

● **SHOW FORM**

The factory default is list display, you can choose normal display, list display or bar display according to the sub-function menu prompt or ENTER key.

● **HARM ITEM**

The factory default setting is voltage, you can choose voltage, current, voltage and current according to the sub-function menu prompt or ENTER key.

● **DATA MODE**

The factory default setting is percentage mode, you can choose percentage, absolute value according to the sub-function menu prompt or ENTER key.

Note: Percentage: the percentage value of the corresponding value (0~100%)

Absolute value: the real number relative to the percentage

The total harmonic distortion is displayed as a percentage, so the data mode does not apply to the total harmonic data.

● **RETURN**

Only appears in the submenu, press this soft key to return to the previous soft key menu.

4.4.1 HARM Common Display

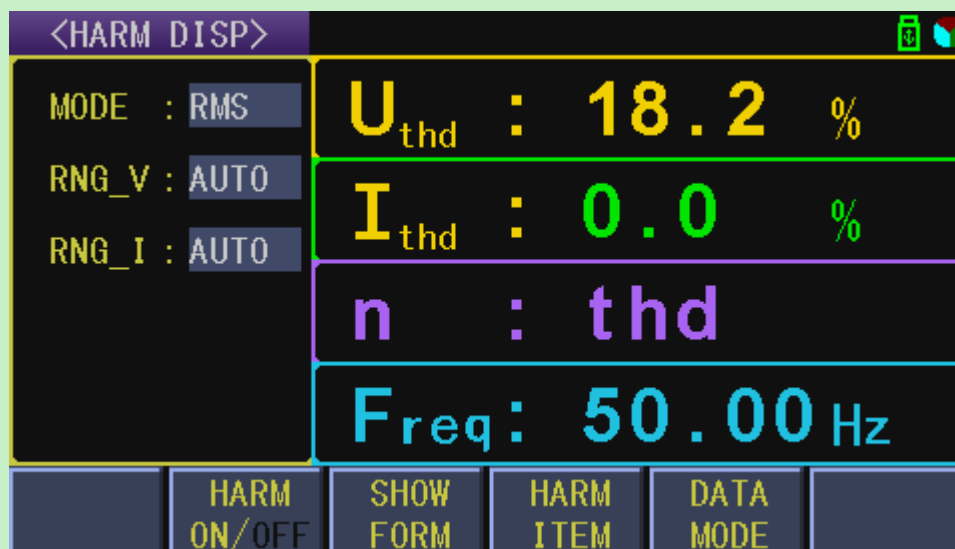

Figure 4-8 Common display for Harmonic display interface

The left area is a simple display of the current test conditions and cannot be modified. If necessary, the modification operation can be completed before entering the page. The other area content definitions are similar to the <MEAS DISP A> page;

In this common display form, there are two cases for the definition of the corresponding four window parameters, as shown in Tables 4-2 and 4-3:

1) Under the condition of only analyzing voltage or current:

Window position	Corresponding display function
Functional parameter 1	Fixed display percent of voltage or current total harmonic
Functional parameter 2	Display the harmonic (value or percentage) of the corresponding nth harmonic.
Functional parameter 3	Display the harmonic order n (2~50), you can press the up/down direction keys to switch.
Functional parameter 4	Fixed display the frequency of the input signal.

Table 4-2 Only analyzing voltage harmonic or current harmonics

2) Under conditions of simultaneous analysis of voltage and current:

Window position	Corresponding display function
Functional parameter 1	According to the value of n, when the value of n is not in the range of (2~50), the total harmonic percentage of the voltage is displayed, otherwise the voltage of the nth harmonic is displayed.
Functional parameter 2	According to the value of n, when the value of n is not in the range of (2~50), the total harmonic percentage of the current is displayed, otherwise the current of the nth harmonic is displayed.
Functional parameter 3	Display harmonic order n (2~50) or total harmonic mark, you can press the up/down direction keys to switch the number of times.
Functional parameter 4	Fixed display the frequency of the input signal

Table 4-3 Simultaneous analysis of voltage and current harmonic

4.4.2 HARM List Display



<HARM DISP>			
Order (U)	Harm(%)	Order (I)	Harm(%)
2nd	15.0	2nd	0.0
3th	0.0	3th	0.0
4th	10.1	4th	0.0
5th	0.0	5th	0.0
6th	2.0	6th	0.0
7th	0.0	7th	0.0
8th	0.0	8th	0.0
9th	0.0	9th	0.0
10th	0.0	10th	0.0

Common List Bar return

Figure 4-9 List display for Harmonic display interface

- The main display area is divided into two groups. The left side of each group shows the harmonic order, and the right side shows the corresponding result;
- When the harmonic analysis item is set to voltage and current, the harmonic analysis list results are shown in Figure 3-9. The left group shows the results of voltage harmonic analysis, and the right group shows the results of current harmonic analysis. The parameter symbol and unit prompt are displayed in the above of the results to indicate whether the result of the column is voltage or current;
- If the harmonic analysis item is set to voltage or current, the left and right groups display the harmonic analysis result of voltage or current, and the harmonic order rises in order;
- Press the up/down direction key to perform the page turning operation. There is a scroll bar on the right side of the result area to turn the page to display the harmonic analysis results of other times.

4.4.3 HARM Bar Display



Figure 4-10 Bar graph display for Harmonic display interface

- The above figure shows the results displayed in the bar show form of the harmonic analysis. The abscissa indicates the harmonic order of the 2~50th harmonic;
 - The ordinate indicates the percentage corresponding to each harmonic, up to 45%;
- If the harmonic analysis item is set to voltage and current, the voltage harmonics are displayed on the left side of the same histogram, and the current harmonics are displayed on the right side. The color is different.

Setup steps:

- 1) Press the up and down direction keys to adjust the display range of the vertical ordinate; It is mainly to adjust the maximum display limit and the default display range is 0~50%; you can press the up and down keys to adjust the maximum limit. The adjustable range is: 0~5%, 0~10%, 0~15%, 0~20%, 0~25%, 0~30%, 0~35%, 0~40%, 0~45%, 0~50%;
- 2) Press the left and right direction keys to adjust the display range of the horizontal coordinate; It is mainly to adjust the maximum harmonic display times, the default display range is 2~50; press the left and right keys to adjust the maximum harmonic display times. The adjustable range is: 2~10, 2~15, 2~20, 2~25, 2~30, 2~35, 2~40, 2~45, 2~50;

Note: After adjusting properly, you can adjust the aspect ratio of the graphic display, which makes the graphic display more full and detailed.

4.5 <WAVE DISP> Interface

Press <DISP> and select the **WAVE DISP** soft key to enter into the <WAVE DISP> page shown as figure 4-11. The waveform display only provides the user with basic source data information. The display details of the waveform cannot be compared with the oscilloscope.

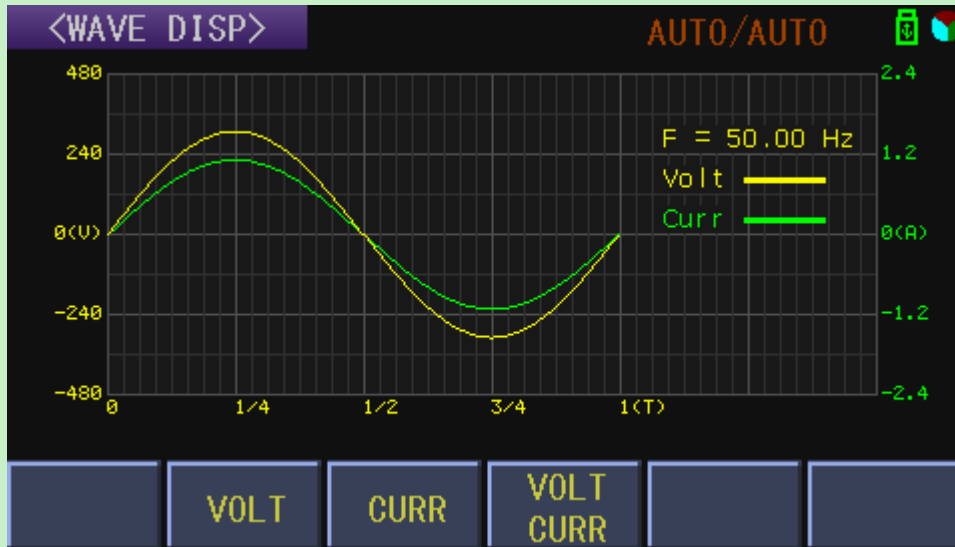

Figure 4-11 Waveform display interface

4.5.1 Waveform display description

The result of the waveform display is to show the data in one source period.

- Waveform drawing parameters can be selected through the soft key: **VOLT**, **CURR**, **VOLT and CURR**;

- When selecting **VOLT**: the waveform and the label are both yellow, and the frequency corresponds to the frequency of the voltage channel;

When selecting **CURR**: the waveform color changes to green, and the frequency corresponds to the current channel frequency;

When selecting **VOLT and CURR**: the left side is marked yellow, the corresponding yellow waveform indicates the voltage waveform and the corresponding label of the voltage waveform; the right side is marked with green, and the corresponding green waveform indicates the current waveform and the corresponding label of the current waveform; the corresponding parameters of frequency test, refer to the special instructions below;

Special note: When the voltage and current waveforms are displayed at the same time, the frequency has an automatic search function; the user can see whether the current frequency belongs to the voltage path or the current path according to color change of the frequency measurement result and compare the color of the waveform.

- If the waveform is truncated, the measurement data is over-range. If the voltage or current range is automatic, the corresponding label will automatically adjust with the range change. Generally, this phenomenon does not occur.
- The result of waveform display is through zero synchronization adjustment, but the original phase difference between voltage and current is not changed; if the input voltage and current are both DC, waveform data is not displayed.

4.5.2 Waveform display with harmonics

With the harmonic component input, turning on the waveform display, the waveform effect with the harmonic input will be displayed, as shown in Figure 4-12 below.

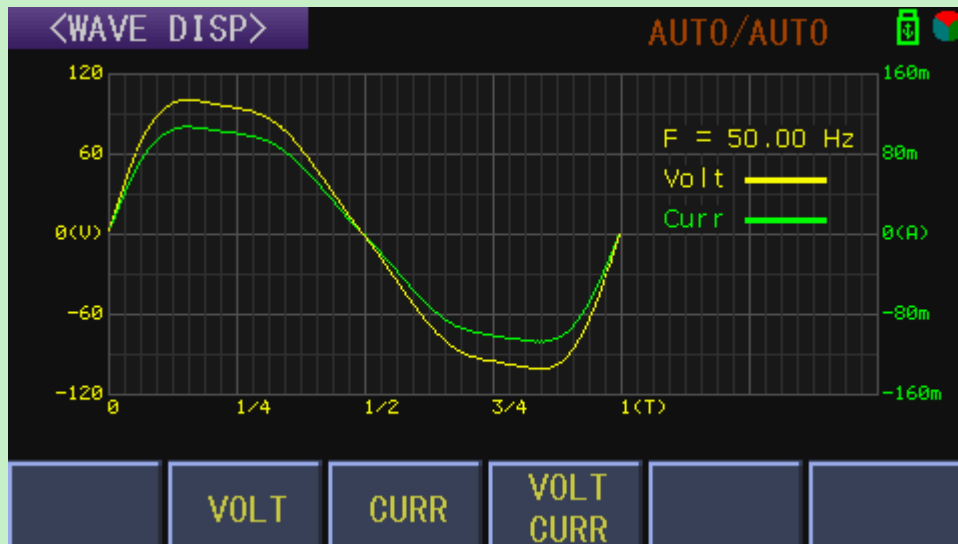

Figure 4-12 Input waveform with harmonic components

4.6 <MEAS SETUP> Interface

Press the SETUP key and then press MEAS SETUP in the soft key area to enter the <MEAS SETUP> page. As shown in Figure 4-13.

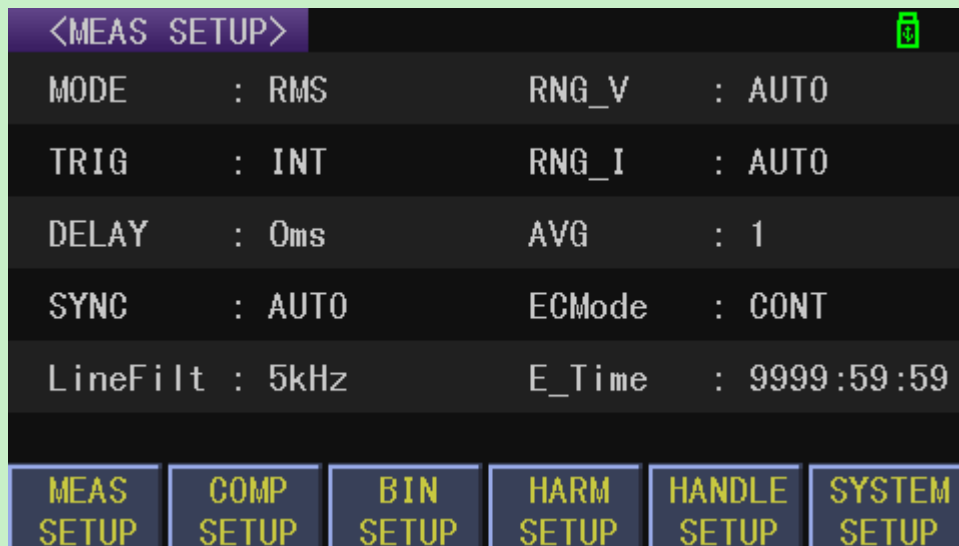

Figure 4-13 The measurement setup interface

This page is mainly to provide the necessary test conditions for normal measurement. The specific parameters that can be set are as follows.

4.6.1 MODE

Setup steps: See the test mode settings under the <Measurement Display A> page.

4.6.2 TRIG

TH33XX series has the following four trigger modes: internal trigger (INT), manual trigger (MAN), external trigger (EXT) and bus trigger (BUS). The factory default setting is internal trigger (INT).

Setup steps:

- 1) Move the cursor to the **TRIG** area, and the following soft keys are displayed in the soft key area of the screen.
 - **INT**: make continuous measurement of the DUT and output of the results;
 - **MAN**: press the TRIGGER button in the panel, the meter will make a measurement and display the result, otherwise it is in the waiting state;
 - **EXT**: after receiving the “start” signal (usually the falling edge, which cannot be modified) from the outside through the HANDLER port on the rear panel, perform a measurement and output the measurement result, and then enter the waiting state again;
 - **BUS**: used to set the trigger test by bus instruction;
- 2) Press the corresponding soft key or press ENTER to complete the corresponding settings.

4.6.3 DELAY

It is used to set the delay time between receiving the trigger signal and executing the test. The factory default setting is 0ms.

Setup steps of method 1:

- 1) Move the cursor to the **DELAY** area, and the following soft keys are displayed in the soft key area of the screen.
 - **INCR++**: increase the setting data with larger interval;
 - **INCR+** : increase the setting data with smaller interval;
 - **DECR-**: decrease the setting data with larger interval;
 - **DECR--**: decrease the setting data with smaller interval;
- 2) Press the corresponding soft key to complete the increase or decrease setting.

Setup steps of method 2:

- 1) Move the cursor to the **DELAY** area, the screen soft key area displays the same as above, directly input the number to be set on the numeric keypad, and the following soft keys are displayed in the soft key area of the screen.
 - **ms**: Enter the entered number in ms units as the final value input;
 - **s** : Enter the entered number in s as the final value;
- 2) Press the corresponding soft key or ENTER key to complete the corresponding settings.

Remarks: The data range is 0ms~60.00s and the resolution is 1ms.

4.6.4 SYNC

It is used to set the synchronization source of AD sampling. The factory default setting is AUTO.

Setup steps:

1) Move the cursor to the **SYNC** area, and the following soft keys are displayed in the soft key area of the screen.

- **AUTO**: used to set the AD sampling synchronization as automatic selection;
- **VOLT**: used to set the AD sampling synchronous to lock on the voltage channel;
- **CURR**: used to set the AD sampling synchronous to lock on the current channel;
- **POWER**: used to set the AD sampling synchronization to lock on the instrument fundamental frequency power supply;

2) Press the corresponding soft key or press the ENTER key to complete the corresponding settings.

Considering the actual use, TH33XX series instruments divide the test synchronization into signal source synchronization and line power synchronization and adopt the flexible semi-automatic control mode.

Suggestions and instructions for use:

a) For regular signals, it is recommended to keep the initial setting and set the SYNC to AUTO, the system will select the appropriate signal to complete the synchronization. If the test input signal is pure DC or the frequency is too low (less than 40Hz), in order to speed up the measurement, the system will temporarily switch the synchronization source to the line power frequency (50/60Hz), which is beneficial to test the DC signal. If the input terminal suddenly inputs a valid AC signal, the system will synchronize back to the signal source for synchronization;

b) If the input source is independent of the line power and is a valid AC source (45Hz~400Hz), it is recommended to set the SYNC to “Source” synchronization, otherwise, the test result may cause errors due to out of sync.

c) If the input source is used in parallel with the line power (instrument AC power supply), in order to speed up the test stability, it is recommended to set the SYNC to “line power” synchronization (50/60Hz), so that the unlock of the phase-locked loop due to the loss of the signal will not occur when replacing the measured load, thus making the phase-locked loop inside the instrument in a stable working state at all times;

d) For special system tests, the voltage or current signal may be distorted and the signal test is abnormal. Here, the synchronous channel lock setting is provided. For example, when some motor is tested, the voltage signal will be deformed, and the current signal is relatively consistent with the standard sine wave. The SYNC can be locked on the current channel; if the related equipment such as the inverter is tested, the current will be deformed, and the voltage signal is relatively in accordance with the standard, and the synchronization signal can be locked in the voltage channel.

4.6.5 LineFilt

It is used to set the filtering function for signal processing, the factory default setting is 5 kHz, that is, the filter switch is turned on.

Setup steps:

1) Move the cursor to the LineFilt area, and the following soft keys are displayed in the soft key area of the screen.

- **5kHz**: Turn on the 5kHz line filter switch;
- **OFF**: Turn off the line filter switch;

2) Press the corresponding soft key or press the ENTER key to complete the corresponding settings.

Note: If there is a need to see the harmonic state of the non-power frequency signal input, this filter needs to be turned off, otherwise the harmonic signal may be attenuated severely.

4.6.6 Range

See the test range in the <Measurement Display> page for details.

4.6.7 AVG

It is used to set the average number of times required for sampling, that is, the average value is counted as one display after N times of sampling. The factory default setting is 1.

Setup steps of method 1:

1) Move the cursor to the **AVG** area, and the following soft keys are displayed in the soft key area of the screen.

- **INCR +**: increase the average number of times;
- **DECR -**: reduce the average number of times;

2) Press the corresponding soft key to complete the increase or decrease setting

Setup steps of method 2:

1) Move the cursor to the **AVG** area, the screen soft key area displays the same as above, directly input the number to be set on the numeric keypad, and the following soft keys are displayed in the soft key area of the screen.

- **x1**: Enter the entered number as the final value;

2) Press the corresponding soft key or ENTER key to complete the corresponding settings.

Remarks: Data range is 1~32.

4.6.8 ECMode

It is used to set the control mode for energy integral, the factory default setting is CONT (continuous control).

Setup steps:

1) Move the cursor to the **ECMode** area, and the following soft keys are displayed in the soft key area of the screen.

- **Manual (MAN)**: Set the energy integral model to manual control;
- **Continuous (CONTU)**: Set the energy integral model to continuous control;

2) Press the corresponding soft key or ENTER key to complete the corresponding settings.

Function Description:

- Manual control means that the energy integral function is activated by manually pressing the RUN button, and the integral clock (positive timing) is displayed at the dialog box position until the STOP button is pressed manually;
- Continuous control means that the energy integral function is activated after the RUN button is pressed manually, and the integral clock (countdown) is displayed at the dialog box position, and the stop integral function is stopped when the set integral time is reached or the STOP button is pressed;

4.6.9 E_Time

It is used to set the countdown time in the energy continuous integral control mode. The factory default setting is the maximum time, which is 9999 hours, 59 minutes and 59 seconds.

Setup steps:

See the procedure for the date and time setting on the <SYSTEM SETUP> page.

4.7 <COMP SETUP> Interface

Press the SETUP key and then press **COMP SETUP** in the soft key area to enter the <COMP SETUP> page.

This page mainly provides comparison conditions for the comparison function of the <COMP DISP > page. The specific parameters that can be set are as follows, as shown in Figure 4-14.



<COMP SETUP>							
Handle1	:	U		Handle2	:	I	
Handle3	:	P		Handle4	:	PF	
Para	Low	High	ON	Para	Low	High	ON
U _{RMS}	0	600.0	✓	I _{RMS}	0	0	✓
Upk+	-999.9	999.9	✓	Ipk+	0	0	✓
Upk-	-999.9	999.9	✓	Ipk-	0	0	✓
Uthd	0%	99.99%	✓	Ithd	0%	0%	✓
P	0	0	✓	PF	0	0	✓
VA	0	0	✓	Freq	0	0	✓
VAR	0	0	✓	CFi	0	0	✓

MEAS SETUP COMP SETUP BIN SETUP HARM SETUP HANDLE SETUP SYSTEM SETUP

Figure 4-14 The compare setup interface

4.7.1 Handle Parameters Setup

It is used to set the corresponding control parameters of the four Handle output ports. The default parameters of the four channels are the voltage (U), current (I), power (P), and power factor (PF).

TH3311 series only provide four Handle output control ports and the control parameters of the four ports can be arbitrarily selected between the parameters displayed in the soft key area. For the parameters that can be set, see Figure 4-5 in the <COMP DISP> page and its introduction;

After setting, you need to set the external output mode of the corresponding output port on the <HANDLE SETUP> page, and then enter the <COMP DISP> page. When the comparison switch is turned on, the comparison result of the corresponding parameters will directly control the corresponding signal output of the Handle port.

Setup steps:

- 1) Move the cursor to the Handle [1~4] area respectively;
- 2) According to the soft key prompt or press ENTER to select the setting.

The instrument with no harmonic analysis function has only 12 parameters, no Uthd and Ithd;

For instruments with harmonic analysis, the precondition for selecting (Uthd or Ithd) is that the harmonic analysis switch is turned on (see the Harmonic Switch section of the <HARM SETUP> page for the open mode); otherwise the comparison switch for these two parameters cannot be turned on.

4.7.2 Compare Limit Setup

It is used to set the upper and lower limits of the comparison function. The factory default setting is 0.

Setup steps:

- 1) Move the cursor to the **LOW** and **HIGH** areas on the right side of the corresponding parameter, and the following soft keys are displayed in the soft key area of the screen.

- **CLEAR**: Clear the original data at the current cursor position;
- **LINE CLEAR**: Clear the upper and lower limit data of the corresponding parameter at the current cursor position;

- 2) You can press the relevant soft key to operate or directly input the data you want to set using the numeric keypad.

- 3) After the number is input, the cursor area changes to the red input state, and the soft key area displays the order of magnitude and unit corresponding to the relevant parameter;

- 4) Press the corresponding soft key or press the ENTER key to complete the setting;

Note: Considering that the set value has a usable value, there are some basic setup requirements when setting the upper and lower limits:

- The lower limit must be smaller than the upper limit;
- The maximum settable value of different parameters is limited by the instrument. When the input value is out of range, it will be automatically set to the limit value.

4.7.3 Independent comparison switch

TH33XX series instruments can be set up for each comparison parameter. The factory default setting only turns on the comparison switch of 4 parameters, namely U, I, P, PF.

Setup steps:

- 1) Move the cursor to the corresponding “**ON**” area on the right side of the parameter. The

following soft keys are displayed in the soft key area of the screen.

- **OFF**: it is used to turn off the comparison switch of the corresponding parameter;
- **ON**: it is used to turn on the comparison switch of the corresponding parameter;

2) Press the corresponding soft key or press the ENTER key to complete the setting.

Switch status description:

The color of the open function "✓" for the corresponding parameter indicates the open state of the switch, gray indicates "OFF", means that the parameter does not participate the comparison; Green means "ON".

4.8 <BIN SETUP> Interface

Press the SETUP key and then press **BIN SETUP** in the soft key area to enter the <BIN SETUP> page.

This page is mainly for the corresponding limit setting of the instrument sorting function. The corresponding upper and lower limits can be entered directly in absolute mode, or the corresponding nominal and percentage offsets can be set in percentage mode.

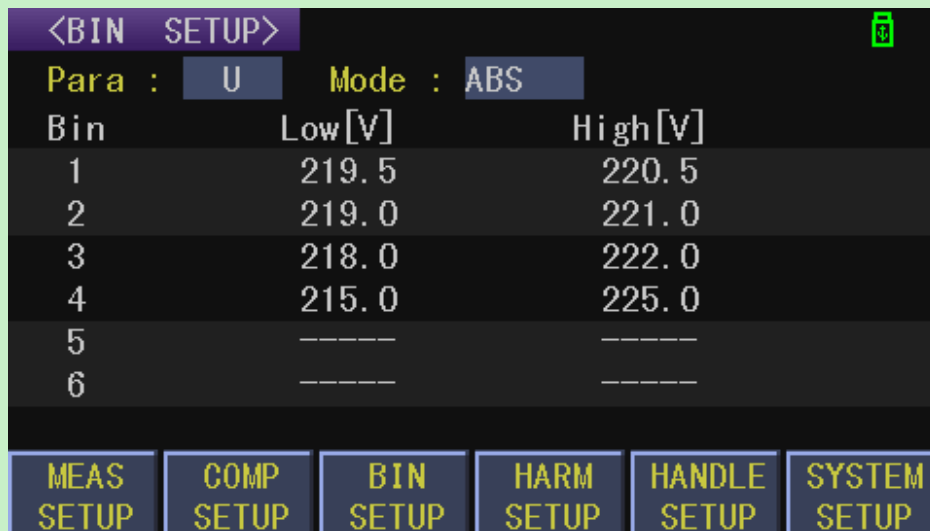

Figure 4-15 BIN setup interface - absolute value mode



Figure 4-16 BIN setup interface - percentage mode

4.8.1 BIN parameter selection

It is used to select the BIN parameter in BIN page. The factory default setting is voltage (U). To set the parameter that needs to be sorted. For the parameter that can be set, see Figure 4-5 of the <COMP DISP> page and its introduction.

Setup steps:

- 1) Move the cursor to the **Para** area, and the screen soft key area displays the parameters that can be set;
- 2) Press the corresponding soft key area or press the ENTER key to complete the modification.

4.8.2 Data Mode

It is used to indicate the data mode for limit setting data. The factory default setting is the absolute value mode.

Setup steps:

- 1) Move the cursor to the **Mode** area and the following soft keys are displayed in the soft key area of the screen.

- **Percentage (%)**: used to set the upper and lower limits to display as a percentage error mode;
- **Absolute value (ABS)**: used to set the upper and lower limits to display the absolute value error mode.

- 2) Press the corresponding soft key or press the ENTER key to complete the setting.

Note: in the percentage mode, the nominal value of the corresponding parameter should be available.

4.8.3 Nom

The nominal value used to provide the offset for the file selection data mode in percent mode. The factory default setting is 0.

Setup steps:

- 1) Move the cursor to the **Nom** area and the following soft keys are displayed in the soft key area of the screen.

- **CLEAR**: Clear the original data at the current cursor position;
- 2) You can press the relevant soft key to operate or directly enter the data you want to set using the numeric keypad.
 - 3) After the number key is input, the cursor area changes to the red input state, and the soft key area displays the order of magnitude and unit corresponding to the relevant parameter;
 - 4) Press the corresponding soft key or press the ENTER key to complete the setting;

4.8.4 BIN Limit Settings

It is used to provide upper and lower limits for the comparison function. The factory default setting is 0. According to different modes, the upper and lower limits are divided into percentage

values (-100~100) and absolute values.

Setup steps:

1) Move the cursor to the **High** and **Low** limit areas on the right side of the corresponding bin number, and the following soft keys are displayed in the soft key area of the screen.

- **CLEAR**: clear the original data at the current cursor position;
- **LINE CLEAR**: clear the upper and lower limit data of the corresponding parameter of the current cursor position;

2) You can press the relevant soft key to operate or directly enter the data you want to set using the numeric keypad.

3) After the number key is input, the cursor area changes to the red input state, and the soft key area displays the order of magnitude and unit corresponding to the relevant parameter;

4) Press the corresponding soft key or press the ENTER key to complete the setting;

Note: The rule of sorting comparison: compare the test result of the selected parameter with the upper and lower limits of BIN1~BIN6, once the appropriate value range is found, the current BIN number is sorted and the result is sorted; The low and high limit are the same and the value is the initial value (0 or empty), and the sorting is also finished, indicating that the following comparison from the current number will have no meaning; here, the range setting of BIN1~BIN6 is included, and the control range of BIN1 is stricter. Users need to pay attention to this comparison rule when setting the limits of each file.

4.9 <HARM SETUP> Interface

Press the SETUP key and then press **HARM SETUP** in the soft key area to enter the <HARM SETUP> page.



Figure 4-17 Harmonic setup interface

4.9.1 HarmON

It is used to set the status switch for setting harmonic analysis, the factory default setting is ON.

Setup steps:

1) Move the cursor to the **HarmON** area, and the following soft keys are displayed in the soft key area of the screen.

- **OFF**: turn off the switch for harmonic analysis
- **ON**: turn on the switch for harmonic analysis

2) Press the corresponding soft key or press the ENTER key to complete the setting;

4.9.2 HarmItem

It is used to set the object for harmonic analysis. The factory default setting is voltage (U).

Setup steps:

1) Move the cursor to the **HarmItem** area, and the following soft keys are displayed in the soft key area of the screen.

- **U**: Set harmonic analysis display only for voltage test
- **I**: Set harmonic analysis display only for current test
- **U+I**: set harmonic analysis display for both voltage and current test

2) Press the corresponding soft key or press the ENTER key to complete the setting;

4.9.3 HarmForm

It is used to set the display form of the harmonic analysis result display. The factory default setting is List.

Setup steps:

1) Move the cursor to the **HarmForm** area, and the following soft keys are displayed in the soft key area of the screen.

- **Normal**: Set the harmonic analysis result to display in normal display
- **List**: Set the harmonic analysis results to display in a list display
- **Bar**: Set the harmonic analysis results to display as a bar display

2) Press the corresponding soft key or press the ENTER key to complete the setting;

4.9.4 CalStd

It is used to provide different standards for total harmonic calculation and the factory default setting is IEC.

Setup steps:

1) Move the cursor to the **CalStd** area, and the following soft keys are displayed in the soft key area of the screen.

- **IEC**: International Electrotechnical Commission Standard
- **CSA**: Canadian Standards Association Standard

2) Press the corresponding soft key or press the ENTER key to complete the setting;

Note: Detailed calculation methods and calculation formulas are described in the section on calculation formulas of the basic principles.

4.9.5 DataMode

It is used to set the harmonic analysis data display mode of each result. The factory default setting is percentage (PER).

Setup steps:

1) Move the cursor to the **DataMode** area, and the following soft keys are displayed in the soft key area of the screen.

- **PER**: Display harmonic analysis results in percentage format
- **ABS**: Display harmonic analysis results in absolute value format

2) Press the corresponding soft key or press the ENTER key to complete the setting;

Note: Data displays involving total harmonics are displayed in percentage format.

4.10 <Handle SETUP> Interface

Press the SETUP button and then press the **HANDLE SETUP** button in the soft key area to enter the <HANDLE SETUP> page. As shown in Figure 4-18:

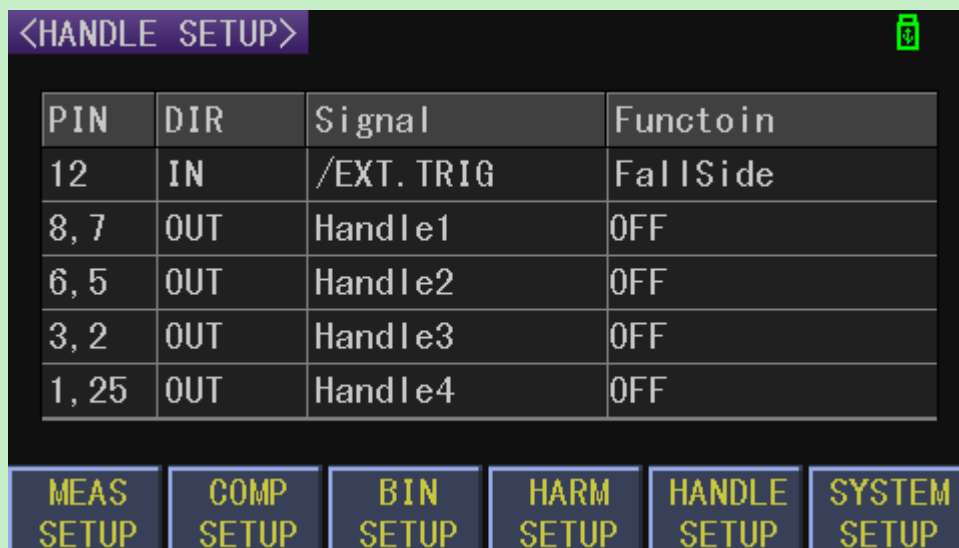

The screenshot shows the <HANDLE SETUP> interface. At the top, there is a title bar with '<HANDLE SETUP>' on the left and a battery icon on the right. Below the title bar is a table with four columns: PIN, DIR, Signal, and Functoin. The table contains five rows of data. At the bottom of the screen, there is a row of six buttons: MEAS SETUP, COMP SETUP, BIN SETUP, HARM SETUP, HANDLE SETUP, and SYSTEM SETUP.

PIN	DIR	Signal	Functoin
12	IN	/EXT. TRIG	FallSide
8, 7	OUT	Handle1	OFF
6, 5	OUT	Handle2	OFF
3, 2	OUT	Handle3	OFF
1, 25	OUT	Handle4	OFF

Figure 4-18 Handle Setup

See the HANDLE Settings section of the Handle Interface Description for details.

Chapter 5 System Setup and File Manage

5.1 System Setup

Press the SETUP button and then press the **SYSTEM SETUP** button in the soft key area to enter the <SYSTEM SETUP> page. As shown in Figure 5-1:



Figure 5-1 System Setup

On this page, the following functions can be set: Key sound, Language, Password, Bus Mode, Baud Rate, 485 Addr, Date and Time.

5.1.1 Key Sound

This function is used to control the opening and closing of button tones. The factory default setting is ON.

Steps for setting the key sound

Touch **Key Sound**, the following soft keys will be displayed:

■ ON

Touch this key to turn on the key sound.

■ OFF

Touch this key to turn off the key sound.

Press the corresponding soft key or press ENTER to complete the corresponding setting.

5.1.2 Language

The function is used to set the language.

Steps for setting the language

Touch **Language**, the following soft keys will be displayed:

- **English**

Touch this soft key to set the language as English.

- **Chinese**

Touch this soft key to set the language as Chinese.

Press the corresponding soft key or press ENTER to complete the corresponding setting.

5.1.3 Password

The function is used to control the password protection mode of the instrument.

Steps for setting the password

Touch **Password**, the following soft keys will be displayed:

- **OFF**

Touch this key to turn off the password protection function.

- **ON**

Touch this key to enable the password function, that is, the power-on password.

- **MODIFY**

Touch this key to modify the password.

Press the corresponding soft key to complete the corresponding setting, or press ENTER to quickly switch the ON or OFF status.

NOTE: The default password is instrument model (33XX). The factory default setting is OFF.

5.1.4 Bus Mode

Touch this zone to select the communication interface.

Steps for setting the bus mode

1) Touch **Bus Mode**, the following soft keys will be displayed:

- **RS232C/485**: one of the two choices, there is no need to install the soft key drive;

- **USBTMC**: there is need to install the soft key driver;

- **USBCDC**: USBVCOM virtual serial port, there is need to install the soft key driver;

Press the corresponding soft key or ENTER key to complete the corresponding settings.

NOTE: USBTMC shares a USB interface with USBCDC, which is the USB device port on the rear panel.

5.1.5 Baud Rate

Touch this key, the following six baud rates is selectable:

- 9600

- 19200
- 28800
- 38400
- 96000
- 115200

5.1.6 485 Addr

It is used to set the bus address used in the optional 485 communication interface and ModeBus command analysis mode. The setting range is from 1 to 31.

Operation Procedures 1:

Touch **485 Addr**, the following items will be displayed in the soft key zone.

- ↑↑ (+ +)

Touch this key, the instrument increases the number of bus address at large intervals.

- ↑ (+)

Touch this key, the instrument increases the number of bus address at small intervals.

- ↓ (-)

Touch this key, the instrument decreases the number of bus address at small intervals.

- ↓↓ (- -)

Touch this key, this instrument decreases the number of bus address at large intervals.

Press the corresponding soft key to complete the increase or decrease setting.

Operation Procedures 2:

1) Move the cursor to the **485 Addr** area, the screen soft key area displays the same as above, directly enter the address size to be set on the numeric keypad, and the following soft keys are displayed in the soft key area of the screen.

- **x1**: 1 times the order of magnitude, namely, to multiply the number to be entered by 1 as the final value input.

2) Press the corresponding soft key or ENTER key to complete the corresponding settings.

5.1.7 Setting Time and Date

It is used to set the correct time for the local time zone.

For example, on the morning of August 15, 2017, 9:13:25, the display format is: 17-08-15 09:13:25.

Operation Procedures 1:

Touch the time zone to be modified, the following items will be displayed.

- ↑↑ (+ +)

Touch this key, the time will increase rapidly at large intervals.

- ↑ (+)

Touch this key, the time will increase at small intervals.

- ↓ (-)

Touch this key, the instrument will decrease at small intervals.

- ↓↓ (- -)

Touch this key, the instrument will decrease at large intervals.

Operation Procedures 2:

1) Move the cursor to the time setting area, the screen soft key area displays the same as above, directly input the number of the number to be set on the numeric keypad, and the following soft keys are displayed in the soft key area of the screen.

- **x1:** 1 times the order of magnitude, namely, to multiply the number to be entered by 1 as the final value input.

2) Press the corresponding soft key or ENTER key to complete the corresponding settings.

(**Note:** Year setting range: 2011~2099, input 11~99)

5.1.8 Command mode setting

The command mode is used to select the command resolution protocol selection in RS232 bus mode.

Setup steps:

1) Move the cursor to the **Cmd Mode** area. The following soft keys are displayed in the soft key area of the screen.

- **SCPI:** this protocol is selected by default;
- **ModeBus:** used by processors with special requirements such as PLC;

2) Press the corresponding soft key or ENTER key to complete the corresponding settings.

(**Note:** ModeBus command analysis mode is only selected for RS232 communication mode)

5.2 <File Manage>

TH33XX series instruments can store user-set parameters in the form of files in the non-volatile memory inside the instrument. The next time you want to use the same settings, the user does not need to reset these parameters, just load the corresponding file, you can get the last set parameters.

5.2.1 File Management Function Interface

After pressing the SETUP key, press **SYSTEM SETUP** button in the soft key area, or press the SETUP key continuously to enter the <SYSTEM SETUP> page, as shown in Figure 5-1. Press the arrow keys on this page to move the cursor to get the file management entry, as shown in Figure 5-2.



Figure 5-2 System file management

The file management entry can be selected to enter the internal file, the external file management page, or enter the management settings of the data save. If the U disk is not detected when the external file is selected, the external file cannot be accessed.

5.2.2 Introduction to Save/Recall

By the function of save/recall, user can save measurement results and configuration information to the internal Flash or external U disk; meanwhile user can recall data from the internal Flash or external U disk. Test results and screenshots can only be saved on an external USB stick.

Symbol Description:

E: is the abbreviation of External, which represents external memory, namely: U disk.

I: is short for Internal, which stands for internal memory, which is the internal Flash of the instrument.

U disk instructions: This instrument is suitable for FAT32 file system, and the allocated unit size is not more than 4096 bytes (U disk formatted settings).

The table below shows the applicable save methods and applications:

Table 5-1 Methods and Applications of Save

Save method		Recall	Application
Type	File format		
Configuration save (internal Flash)	*.STA	Yes	Save the current configuration to internal Flash.
Configuration save (external U disk)	*.STA	Yes	Save the current configuration to a U disk.
Data save (external U disk)	*.CSV	No	Save measurement results to a U disk.
Screen save (external U disk)	*.BMP	No	Save the screen information to a U disk.

5.2.3 Structure of File Folder/File in a U Disk

The internal file management page only provides the root directory operation of the internal storage, that is, the internal file management does not provide folder management; and TH33XX series instrument automatically generates three dedicated folders (namely CSV folder, STA Folder, PIC folder) in the external file (U disk file) management page; STA folder is used to store the parameter setting file (internal files are copied to the external default under this folder), PIC folder is used to store user screenshot files, and CSV folder is used to store test results data.

Under the internal file page, the save file is saved in the root directory of the internal file;

Under the external file page, the saved file location is related to the file path of the previous operation. It can be the root directory of the external file or the currently entered folder. When saving the information to the USB flash drive, it is recommended that the user use the pre-established folder in the memory and root directory of the USB flash drive, as shown in Table 5-2.

Table 5-2 Folders in the USB flash drive

Folder	Maximum Amount of File	Description
CSV	102	Including measurement result, like *.CSV file.
STA	102	Including configuration data, like *.STA file.
PIC	102	Including screen information, like *.bmp file.

NOTE: CSV, STA and PIC folders are automatically generated when a U disk is connected.

Structure of Folder/File in a U disk is shown in figure 5-3.

E: (U disk)

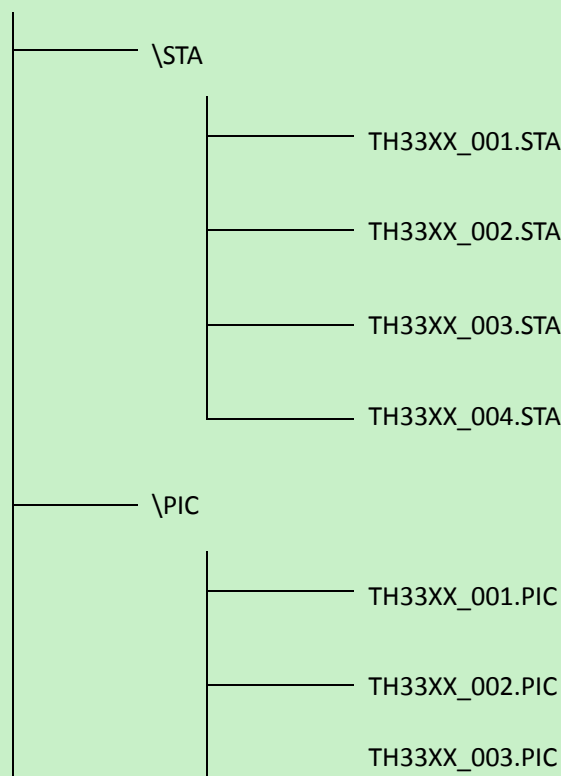

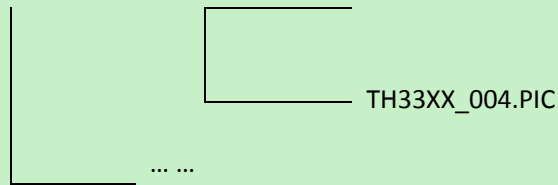

Figure 5-3 file structure in a U disk

When using a U disk on TH33XX, you should pay special attention to the following points:

1. Use a U disk with the USB2.0 interface.
2. This instrument is suitable for FAT32 file system, and the allocated unit size is no more than 4096 bytes (U disk formatted settings).
3. Before connecting the USB flash drive to the TH33XX series, you are advised to back up the data saved on the USB flash drive. Tonghui is not responsible for data loss in the USB storage device when the USB storage device is used with the instrument.
4. In order to rapidly save the instrument data to a U disk, it is not recommended to store too many files or folders.

5.2.4 File Management Operation Procedure

Move the cursor to the file option on the instrument system setting page, and then select **INTER File** or **EXTER File** in the soft key area to enter the internal and external file pages, as shown in Figure 5-4. In addition, after entering the internal and external files, the internal and external file pages can be quickly switched according to the soft key function prompts.

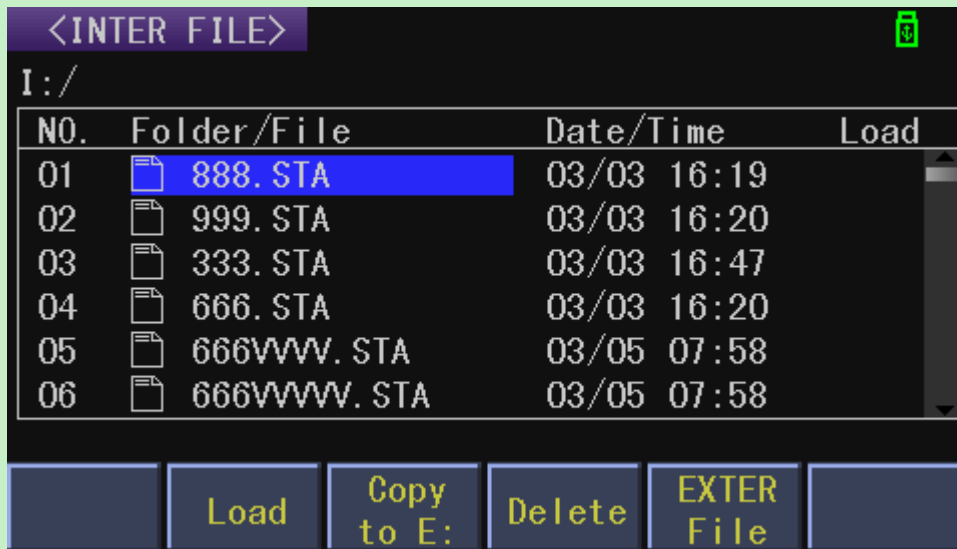

Figure 5-4 Internal file page

The internal file is similar to the operation of the external file. The internal file operation is taken as an example to describe the specific steps of the file operation.

The internal file page and the external file display information of 6 files per page, including the file name and the file storage time.

The various operations on the file are as follows:

Move the cursor to the file name to be edited, and the screen soft key area is displayed as follows:

- **Save**
 When the cursor moves to the empty file area, **SAVE** will be displayed in the soft key area. When this soft key area is pressed, the screen soft key area displays **YES** or **NO**. Select "**NO**" to cancel the current save file operation; select "**YES**", the numerical keyboard will pop up and then you can input the file name and press [ENTER] to finish inputting. The instrument will save the current set parameters to this file.
- **Load**
 When the file name corresponding to the cursor is not empty, and the file type is a configuration file (*.STA file), the soft key area displays **Load**. When this soft key area is pressed, the screen soft key area displays **YES** or **NO**. Select "**NO**" to cancel the current operation; select "**YES**", the instrument will recall the settings in the file and reconfigure the corresponding parameter settings of the instrument according to the recalled content. If the loading operation is performed under the internal file, this loaded file is called each time the power is turned back on to initialize the instrument settings.
- **UnLoad**
 Under the internal file page, when the file corresponding to the cursor has been loaded, the soft key area display **UnLoad**. When this soft key area is pressed, the screen soft key area displays **YES** or **NO**. Select "**NO**" to cancel the current operation; select "**YES**", the instrument will clear the status flag of the file being loaded.
- **Delete**
 When the file name corresponding to the cursor is not empty, the soft key area is displayed **Delete**. When this soft key area is pressed, the screen soft key area displays **YES** or **NO**. Select "NO" to cancel the current operation; select "YES", the instrument will delete the file where the cursor is located.
- **Copy to E:**
 When the file name corresponding to the cursor is not empty, the soft key area display is **Copy to E:**. When this soft key area is pressed, the screen soft key area displays **YES** or **NO**. Select "NO" to cancel the current operation; select "YES", the instrument will copy the file at the cursor to the USB flash drive (in the STA folder).
- **Copy to I:**
 When the file name corresponding to the cursor is not empty, the soft key area display is **Copy to I:**. When this soft key area is pressed, the screen soft key area displays **YES** or **NO**. Select "NO" to cancel the current operation; select "YES", the instrument will copy the file at the cursor to the internal storage (under the root directory).
- **Sub Dir**
 Under the external file page, when the cursor position is not a file but a folder, the soft key area displays the **Sub Dir**. Pressing this soft key area or pressing the ENTER key will enter the subdirectory of the corresponding folder.
- **Parent Dir**
 Under the external file page, when the cursor is not in the root directory of the USB flash drive, the soft key area displays the **Parent Dir**. Pressing this soft key area will return to the parent directory of the corresponding folder.
- **INTER File/EXTER File**
 Quickly switch to the internal and external file display page.

5.2.5 Data Save Settings

After entering the <SYSTEM SETUP> page, press the arrow keys to move the cursor to the **FILE** area. The **DATA SAVE** button can be displayed in the soft key area prompt function. Press this soft key to open or close the data save setting function. After opening the settings, as shown in Figure 5-5, including control mode, count snap or time snap and save switch.

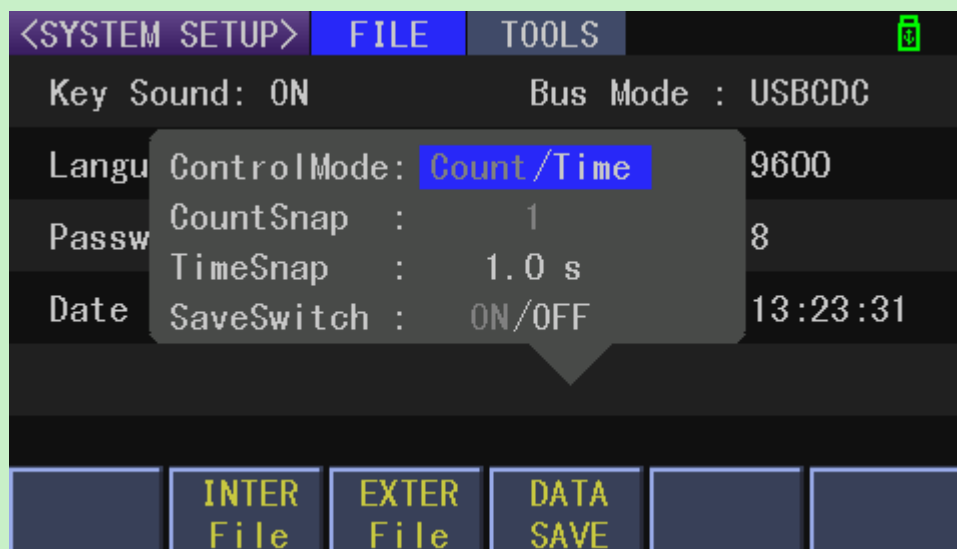

Figure 5-5 Data save settings

Control Mode: used to set the control mode when the test data is saved, that is, count control or time control, and the time control is set by default. The function of the count control is to save the last test result after a certain test count intervals (controllable); the function of the time control is to save the last test result after a certain time interval (controllable).

Count Snap: used for interval setting in the count mode, ranging from 1 to 999;

Time Snap: used for interval setting in the time mode, ranging from 0.2s to 999.9s;

Save Switch: the switch setting for data saving. The data save function will be executed only after it is turned on (requires an available external USB flash).

Setup steps:

- 1) Move the cursor to the **Control Mode** area, press ENTER to switch, white is the selected mode;
- 2) According to the selected control mode, move the cursor to the **CountSnap** or **TimeSnap** area, press the numeric keys to input the desired count intervals or time interval, press ENTER to confirm;
- 3) Move the cursor to the **Save Switch** area and press the ENTER key to switch the switch state of the data save;
 - After ON, the system automatically creates a 33xx_XXX.CSV file in the CSV folder of the USB flash drive, which is used to enter the test page and record the test results (excluding harmonics or waveform data);
 - After OFF, the data saving ends;

(Note: In order to ensure that the data is not too large and reduce the readability of the data or the lack of space on the U disk, please close the current data save function in time after reading the valid data.)

5.3 System Tools

After pressing the SETUP key, press the **SYSTEM SETUP** in the soft key area, or press the SETUP key continuously to enter the <SYSTEM SETUP> page, as shown in Figure 5-1. Press the arrow keys on this page to move the cursor to the **TOOLS** area, as shown in Figure 5-6.



Figure 5-6 System tool options

Tool options include system reset, restore default settings, system update, and query DSP software version.

5.3.1 System Reset

After pressing this **System Reset** soft key, the system will restart.

5.3.2 Default Set

After pressing this **Default Set** soft key, the screen soft key area displays **YES** or **NO**. Select "**NO**" to cancel the current operation; select "**YES**", the instrument will restore all settings to the factory default settings and restart the system;

5.3.3 Update

After the instrument leaves the factory, if the user encounters a bug in the software that needs to be repaired or needs to be customized to modify a certain function during use, after communicating with the company, the designer will upgrade the software according to the questions and needs of the user. After generating the upgrade file (*.SEC), the user can save the obtained upgrade file to the root directory of his U disk, insert the U disk into the instrument, and operate the instrument to perform the upgrade operation.

(Note: The upgrade file needs to be placed in the root directory of the U disk);

5.3.4 DPS Version

A quick entry to the DSP software version is provided to check if the upgraded software is compatible with the DSP program. The DSP program upgrade needs to use the RS-232 interface on the rear panel. Note that you need to modify the jumper cap after removing the chassis to perform the DSP upgrade operation. The steps to upgrade the DSP are as follows:

1) After removing the chassis, switch the jump caps on the DSP side and serial port position as follows:

	Pin 1 - Pin 2	Pin 2 - Pin 3
P5	Short-circuit the two pins with a short-circuit cap during the upgrade, and the two legs are disconnected in normal operation.	
JP43	Right, 232/485 communication	Left, DSP upgrade
JP44	Right, 232/485 communication	Left, DSP upgrade
JP45	Right, 232/485 communication	Left, DSP upgrade
JP46	Right, 232/485 communication	Left, DSP upgrade
Table 0-3 DSP Upgrade jump cap status explanation		

2) After confirming that the P5 short-circuit cap on the left side of the DSP has been plugged in and the JP43, JP44, JP45, and JP46 states are switched correctly, turn the instrument on. Connect the serial communication cable to the computer at the RS232 interface on the rear panel, and use the dedicated programming. Software C2Prog (can be downloaded online or contact the company for sales), load the DSP upgrade program provided by the company to upgrade;

3) After confirming that the DSP upgrade is complete, you need to restore the status of the jump cap of Table 5-3 to the original state, that is, install the chassis after the normal working state.

Chapter 6 Correct Measurement

6.1 Wiring method

TH33XX series instruments provide four test wiring input terminals, namely high voltage, low voltage, high current, low current.

Since the voltage and current are floating inputs, there are many combinations of test wiring methods. The corresponding test circuit can be changed in different applications. Here are two recommended measurement circuit wiring methods.

Tip: Considering the existence of distributed capacitance may affect the test, in order to reduce the influence of distributed capacitance on the test circuit, it is recommended to make the current test end as close as possible to the ground of the input source, that is, the current terminal is connected to the low end of the test circuit.

6.1.1 Internal connection of current terminal

This method is suitable for low-power testing, that is, the test current is relatively small, it is recommended to use, so that the current test is more accurate, and the voltage measurement will produce a small error due to the voltage drop generated by the current on the current meter flow (this error can be ignored). The wiring method and brief principle are shown in Figure 6-1.

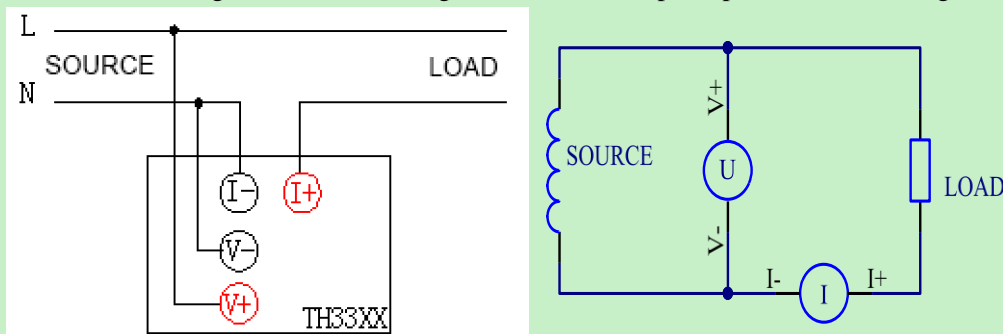

Figure 6-1 Internal connecting method ----- suitable for small current

6.1.2 External connection of current terminal

This method is suitable for high-power load test, that is, the test current is relatively large, it is recommended to use, so that the voltage test is more accurate, and the current measurement will cause a small error due to the voltmeter shunt (this kind of error can be ignored). The wiring method and brief principle are shown in Figure 6-2:

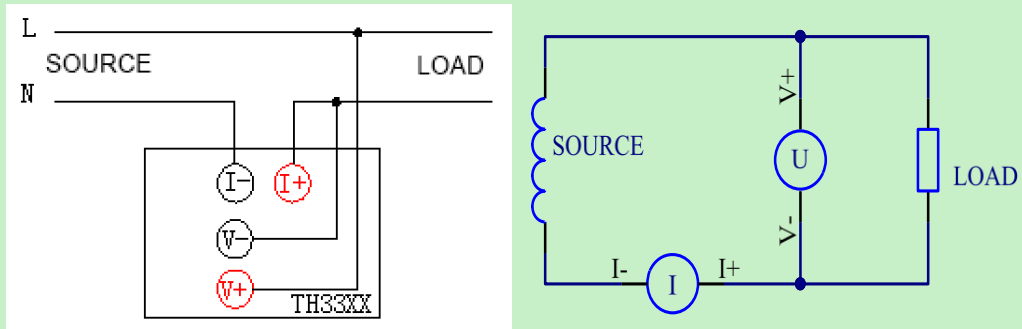

Figure 6-2 External connecting method ----- suitable for large current

Recommended process for connecting the test lines:

1. First connect the positive and negative terminal of the current in series with the load (connected into a loop, and connect the negative terminal to the null line);
2. According to requirements, connect the positive and negative terminal of the voltage to both terminals of the load or both terminals of the input source (that is, the positive terminal of the voltage is connected to the live line, and the negative terminal of the voltage is connected to the positive terminal of the current or the negative terminal of the current);
3. Confirm that the input source's live line is connected to the positive terminal of the voltage and the input source's null line is connected to the negative terminal of the current.

Chapter 7 Basic Principles and Technical Specifications

7.1 Basic principles

System principle and principle block diagram, as shown in Figure 7-1:

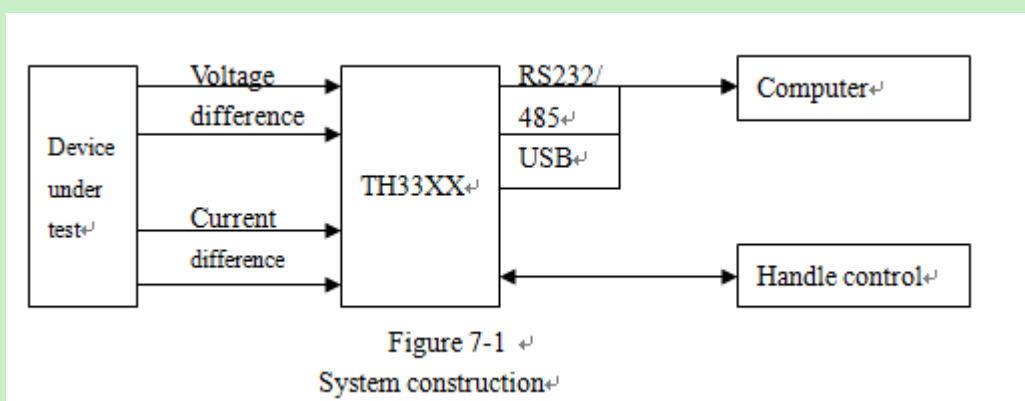

Figure 7-1 System construction

The main structure of the TH33XX series single-phase power meter is to input the voltage and current after being differentiated of the device under test to the instrument, through the internal amplification, filtering, sampling, AD conversion, that is, the analog signals of voltage and current are synchronously sampled and converted into digital quantities U_i and I_i , and then the CPU obtains parameters such as voltage RMS, current RMS, active power and power factor according to the following formula through discrete integration method and sent to the liquid crystal display. Because the calculation of the effective value includes the AC component and the DC component, and the AC waveform may become a non-standard waveform due to partial distortion, so the RMS calculation here is the true effective value, that is, the true RMS value. The calculated power also contains the AC and DC components of the voltage and current, so the power calculation belongs to the average power, which is also the real power value, that is, the active power. The sign of the power represents the flow of power (respectively indicating the energy supplied by the power supply to the load or the energy supplied by the load to the power supply). The power factor is the ratio of active power to apparent power (total power). Theoretically, there is no sign of power factor. However, the application of power meter uses positive and negative signs to determine the phase relationship of voltage and current. Between $-1 \sim +1$, a positive value represents the voltage leading current, and a negative sign represents a voltage behind current.

In addition to the RMS test mode, this series of instruments also provides AC and DC test modes. If the input source includes AC component and DC component, the switchable mode can view the corresponding AC component and DC component respectively.

For harmonics, some instrument models do not have harmonic analysis function, while instruments with harmonic analysis function are for power frequency power signals (50/60Hz). For harmonic results of non-power frequency signals, this series of instruments can view but there is no precision indicator. This series of instruments provides a selectable opening of the 5 kHz

filter. This filter is not suitable for non-power frequency power supplies and needs to be manually turned off (optional in the MEASURE SETUP). The number of harmonics that can be analyzed and viewed is 2~50 times.

7.1.1 Measurement parameters and symbols

U_{RMS} : real available value of Voltage I_{RMS} : real available value of Current
 U_{AC} : voltage AC component RMS I_{AC} : current AC component RMS
 U_{DC} : voltage DC component I_{DC} : current DC component
 Freq: frequency of the input source PF: power factor
 CFu: voltage peak factor P: active power
 CFi: current peak factor VA: total power
 Up-p: voltage peak-to-peak VAR: virtual power
 Ip-p: current peak-to-peak value E: electrical energy
 Upk+/Upk- : voltage positive peak and voltage negative peak
 Ipk+/Ipk- : current positive peak and current negative peak
 Uthd/Ithd: voltage/current total harmonic size (%)
 Uh_n/Ih_n: each harmonic of voltage/current, n: 2~50

7.1.2 Calculation formula

Measured parameters	Calculation formula / calculation method
U_{RMS}	$\sqrt{\frac{1}{T} \int_0^T u^2(t) dt}$
I_{RMS}	$\sqrt{\frac{1}{T} \int_0^T i^2(t) dt}$
P	$\frac{1}{T} \int_0^T u(t)i(t) dt$
VA	$U_{RMS} * I_{RMS}$
VAR	$\sqrt{VA^2 - P^2}$
PF	$\frac{P}{VA}$
U_{DC}	$\frac{1}{T} \int_0^T u(t) dt$
I_{DC}	$\frac{1}{T} \int_0^T i(t) dt$
U_{AC}	$\sqrt{U_{RMS}^2 - U_{DC}^2}$

I_{AC}	$\sqrt{I_{RMS}^2 - I_{DC}^2}$
U_{PK+}	Maximum value in one sampling period $u(t)$
U_{PK-}	Minimum value in one sampling period $u(t)$
I_{PK+}	Maximum value in one sampling period $i(t)$
I_{PK-}	Minimum value in one sampling period $i(t)$
CF_i	The ratio of the absolute value of the sample with the largest absolute value to the current RMS value in one sampling period
THD_u / THD_i	Two calculation standards for the calculation of the total harmonics of voltage and current, namely IEC standard and CSA standard. For details, please see the notes below the table.
$Energy$	$\int_0^T u(t)i(t)dt$ Here, T is the integration time set by the user.
$Freq$	Obtained through the Zero crossing detection

Based on the International Electrotechnical Commission (IEC standard) and the Canadian Standards Association (CSA standard), two calculation methods of the total harmonic calculation are given (optional on the harmonic setting page), which are described as follows:

IEC standard: Calculate the ratio (%) of the root mean square of the effective value of the harmonic components of the 2nd to 50th harmonics and the effective value of the fundamental wave (ie, the first harmonic). The calculation formula is as follows:

$$THD = \sqrt{\sum_{k=2}^N (C_k)^2} / C_1 \quad \text{Total harmonic calculation}$$

$$C_k \% = C_k / C_1 * 100\% \quad \text{kth harmonic percentage component calculation}$$

CSA standard: Calculate the ratio (%) of the root mean square of the effective value of the harmonic components from the 2nd to the 50th harmonics and the root mean square of the 1st to 50th effective values. The calculation formula is as follows:

$$THD = \sqrt{\sum_{k=2}^N (C_k)^2} / \sqrt{\sum_{k=1}^N (C_k)^2} \quad \text{Total harmonic calculation}$$

$$C_k \% = C_k / \sqrt{\sum_{k=1}^N (C_k)^2} * 100\% \quad \text{kth harmonic percentage component calculation}$$

The meaning of the characters used in the above two formulas is explained:

C_1 : the effective value of the fundamental wave (ie, the first harmonic) of U (voltage) or I (current);

C_k : the effective value of the kth harmonic of U (voltage) or I (current);

k: harmonic order index, 2~50

N: maximum harmonic coefficient, which is 50.

$C_k\%$: the percentage component calculation result of the kth harmonic of the voltage or current.

7.1.3 Hardware range

Dual range controllable: voltage range and current range

Mode: automatic, manual (hold, increase, decrease)

The four voltage range is as shown in the following table:

Voltage range is the same for TH33XX series				
Voltage range number	0	1	2	3
Voltage range	75V	150V	300V	600V

The current range is divided into 7 or 8 according to the specific model, as shown in the following table:

Range No. Range /A	0	1	2	3	4	5	6	7
TH3321(2A)	1mA	3mA	10mA	40mA	150mA	500mA	2A	
TH3311/ TH3312(20A)	10mA	30mA	100mA	400mA	1.5A	5A	20A	
TH3331(40A)	10mA	30mA	100mA	400mA	1A	3A	10A	40A

Note: If you are measuring at a fixed range, be sure to select the appropriate range, otherwise the measurement accuracy will be affected.

7.2 Instrument parameter

7.2.1 Overview of overall parameters

Model /name	Digital Power Meter			
	TH3311	TH3312	TH3321	TH3331
Essential feature	AC/DC, power test, precision	AC/DC, power test, harmonic analysis, precision	AC/DC, micro current, power test, harmonic analysis, precision	AC/DC, wide current, power test, harmonic analysis, precision
Display	4.3 inch color TFT display			
Measured parameters	Data, waveform	Data, waveform, harmonic bar graph		
Basic measurement accuracy	0.15% reading+0.2%range+1digit			
Voltage range	5V~600V, Minimum resolution:0.01V			
Current range	0.5mA~20A Minimum resolution:10uA	0.05mA~2A Minimum resolution:1uA	0.5mA~40A Minimum resolution:10u A	
Power range	5mW-12kW	0.5mW-1.2kW	5mW-24kW	
Frequency range	Fundamental frequency range:DC/45Hz-400Hz, bandwidth: 21kHz, filter:5kHz			
Power factor range	-1.000~1.000			
Electric energy integration range	0~99999kWh			
Lock function	Data locking			
Range mode	Auto/manual			
Test speed	8 times / sec (50Hz)	8 times / sec (50Hz), harmonic function is on: 4 times / sec (50Hz)		
Input impedance	$\geq 1M\Omega$ (all voltage ranges)			
Comparator and sorting output	Over-limit sound, light alarm, relay output			
Communication mode	RS232C/RS485, USB, USB waveform, setting files storage			
Power supply	AC220V $\pm 10\%$, 50/60Hz $\pm 5\%$, soft power switch			
Volume and weight	235mm*105mm*360mm (W*H*D); including the shell			

7.2.2 Specific input indicators

Item	Voltage	Current					
	All models	TH3321		TH331X		TH3331	
Range	75V/150V/ 300V/600V	1mA/3mA/ 10mA/40mA	150mA/ 500mA/ 2A	10mA/30mA/ 100mA/400mA	1.5A/5A/ 20A	10mA/30mA/ 100mA/400mA	1A/3A/ 10A/40A
Input impedance	> 1MΩ	2Ω	200mΩ	200mΩ	4mΩ	200mΩ	2mΩ
1s instantaneous maximum allowable input	1000V	4A		40A		80A	
Continuous maximum allowable input	700V	3A		30A		60A	
Maximum display	Range*110%						

7.3 Precision index

(This basic accuracy is obtained at a temperature of 20°C ± 5°C; temperature coefficient: ±0.005%/°C)

7.3.1 Voltage test accuracy

Model: TH33XX			
Range	Resolution	Basic accuracy (one year)	
		DC, 45~75Hz	75~400Hz
75V	0.01V(<100V) 0.1V(>=100V)	±(0.15%reading+0.2%range+1 digit)	±(0.3%reading+0.2%range+1 digit)
150V			
300V			
600V			

7.3.2 Current test accuracy

Model: TH3321(microcurrent 2A)			
Range	Resolution	Basic accuracy (one year)	
		DC, 45~75Hz	75~400Hz
1mA/3mA	1uA	$\pm(0.15\% \text{ reading} + 0.2\% \text{ range} + 1 \text{ digit})$	$\pm(0.3\% \text{ reading} + 0.2\% \text{ range} + 1 \text{ digit})$
10mA/40mA/ 150mA	10uA(<0.1A) 0.1mA(0.1A~1A)		
500mA/2A	1mA(>=1A)		

Model: TH3311/TH3312(regular 20A)							
Range	Resolution	Basic accuracy (one year)					
		DC, 45~75Hz		75~400Hz			
10mA/30mA 100mA	0.01mA (<0.1A) 0.1mA(0.1A~1A) 1mA(1A~10A) 10mA(>=10A)	$\pm(0.15\% \text{ reading} + 0.2\% \text{ range} + 30 \text{ digit})$		$\pm(0.3\% \text{ reading} + 0.2\% \text{ range} + 30 \text{ digit})$			
400mA		$\pm(0.15\% \text{ reading} + 0.2\% \text{ range} + 10 \text{ digit})$		$\pm(0.3\% \text{ reading} + 0.2\% \text{ range} + 10 \text{ digit})$			
1.5A		<1A	$\pm(0.15\% \text{ reading} + 0.2\% \text{ range} + 10 \text{ digit})$		<1A	$\pm(0.3\% \text{ reading} + 0.2\% \text{ range} + 10 \text{ digit})$	
		>=1A	$\pm(0.15\% \text{ reading} + 0.2\% \text{ range} + 1 \text{ digit})$		>=1A	$\pm(0.3\% \text{ reading} + 0.2\% \text{ range} + 1 \text{ digit})$	
5A/20A		$\pm(0.15\% \text{ reading} + 0.2\% \text{ range} + 1 \text{ digit})$		$\pm(0.3\% \text{ reading} + 0.2\% \text{ range} + 1 \text{ digit})$			

Model: TH3331(large current 40A)			
Range	Resolution	Basic accuracy (one year)	
		DC, 45~75Hz	75~400Hz
10mA/30mA/ 100mA/	0.01mA (<0.1A)	$\pm(0.15\% \text{ reading} + 0.2\% \text{ range} + 30 \text{ digit})$	$\pm(0.3\% \text{ reading} + 0.2\% \text{ range} + 30 \text{ digit})$
400mA/1A	0.1mA(0.1A~1A) 1mA(1A~10A)	$\pm(0.15\% \text{ reading} + 0.2\% \text{ range} + 10 \text{ digit})$	$\pm(0.3\% \text{ reading} + 0.2\% \text{ range} + 10 \text{ digit})$
3A/10A/40A	10mA(>=10A)	$\pm(0.15\% \text{ reading} + 0.2\% \text{ range} + 1 \text{ digit})$	$\pm(0.3\% \text{ reading} + 0.2\% \text{ range} + 1 \text{ digit})$

7.3.3 Test accuracy for other parameters

Model :TH33XX				
Parameter	Test range	Minimum resolution	Basic accuracy (one year)	
			DC, 45~75Hz	75~400Hz
Active power	U*I*PF	0.001mW(TH3321) 0.01mW(other)	±(0.2%reading+0.3%range)	
Power factor	0.1~1.000	0.001	±0.01	
Frequency	45~400	0.01	0.1% reading +1digit	0.1%reading+1digit
Energy accumulation	0~99999kWh	0.001Wh	±(0.2%reading+0.3% range)	
Energy timing	0~9999:59:59	1second	±0.05%	
Harmonic test	2~50 times		±(5% reading +0.3% range)	No

Remark: Voltage and current overload limit is 1.1 times of full scale; power factor measurement accuracy requires that the voltage amplitude is higher than 10% range and current amplitude is higher than 1% range; frequency test requires that the voltage amplitude is higher than 10% range or current amplitude is higher than 1% range.

Chapter 8 Remote Control

8.1 RS232C Connection

RS-232 standard, also called as asynchronous serial communication standard, has already been widely used for data communication between computers, computer and external equipment. RS is the English abbreviation of Recommended Standard; 232, the standard number. This standard is issued by EIA in 1969, which rules to send one bit in a data line every time.

As most serial interfaces, the serial interface of TH33XX is also not strictly based on RS-232 standard but only uses the smallest subset of this standard. The signals are listed in the following table.

Signal	Code	Connector Pin Number
Transmitted Data	TXD	2
Received Data	RXD	3
Signal Ground Common	GND	5

Table 8-1 RS-232 Signal and Pin Connector

The reason is that the use of three lines is much more inexpensive and much simpler than that of five lines or six lines, which is the biggest advantage of using serial interface for communication.

The connection of the instrument with PC is shown in figure 8-1.

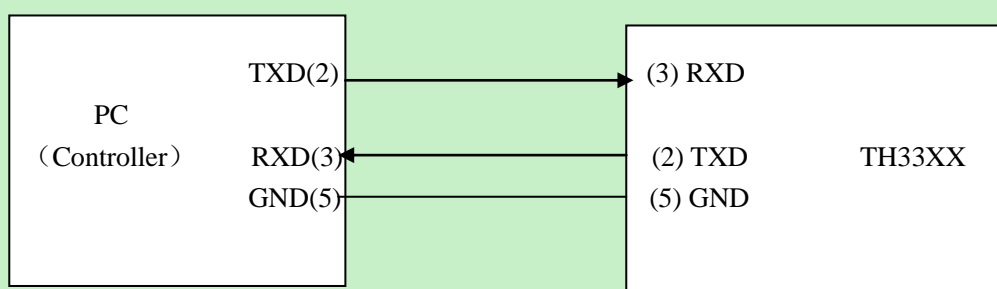

Figure 8-1 Connection of the instrument with PC

Figure 8-1 shows that the serial interface pin definition of this instrument is different from that of 9 pin connector used in the computer. User can purchase the serial interface cable from our company.

RS232 interface characterizes with a baud rate ranging from 9600 to 115200, no parity, 8-bit data bit, 1-bit stop bit.

The instrument commands comply with the SCPI standard. When a command string is transmitted to the instrument, it is required to send LF (hexadecimal: 0AH) as the terminating character. Each

time the maximum receivable number of SPCI command string is 2kB.

For result data formats transmitted to a PC from the instrument, see Commands Reference.

8.1.1 SCPI (Standard Commands for Programmable Instruments)

SCPI is a new general command based on the IEEE488.2-1987 standard. (SCPI is the same as TMSL, a system language for measurement testers adopted by HP.)

8.1.2 ModeBus Command Protocol

In order to be compatible with PLC instruction processing such as PLC, which is not good at string processing, the instrument provides ModeBus instruction analysis mode in RS232 communication mode. For detailed instruction format and instrument function instruction list, see Section 9.3 ModeBus instruction.

8.2 RS485 Interface Description

RS485 interface adopts a combination of balanced driver and differential receiver, which has enhanced anti-common-mode interference capability, that is, good anti-noise interference. In addition, RS485 signal transmission distance (about 1219m) is farther than RS232, and a bus generally supports up to 32 nodes. If a special 485 chip is used, the number of mountable nodes will increase.

The interface comparison is shown in Table 8-2.

Signal	abbreviation	Connector pin number
Data+	485+	1
Data-	485-	4

Table 8-2 Instrument RS485 signal and pin comparison

RS485 uses two-wire connection method and shares an external interface with RS232, which is easy to use and does not interfere with each other.

TH33XX series instrument has a hardware decoder which can transfer 485 to 232. If the user customizes the instrument with 485 communication protocol, the baud rate, parity bit, data bit, stop bit and other related configurations required for communication should be configured before the specific communication.

8.2.1 RS485 address

RS485 serial communication interface bus mode address range is 1~31, its setting can refer to the bus address item in <SYSTEM SETUP> page.

8.3 USBTMC Remote Control System

USB (Universal Serial Bus) remote control system controls the instrument through the USB interface. This connection conforms to USBTMC-USB488 and USB2.0 protocols.

8.3.1 System Configuration

Connect the USB interface on the rear panel of the TH33XX series instrument to the USB interface on PC via a USB cable.

8.3.2 Install the Driver

When TH33XX is first connected to a PC through a USB cable, the prompt information –Found New Hardware will show on the right bottom of the computer desktop, as is shown below:

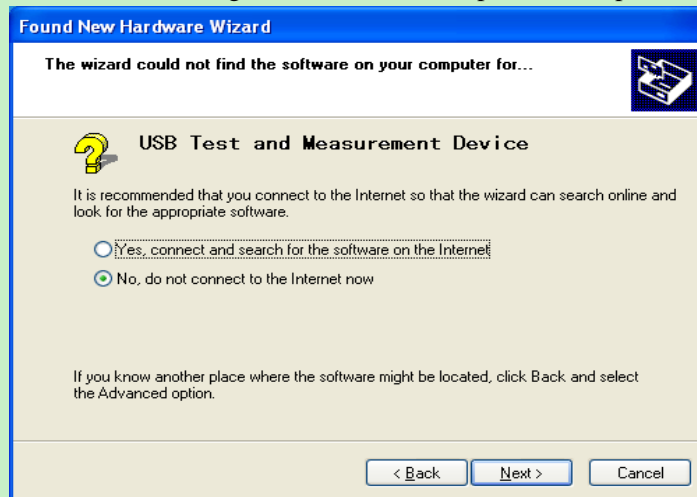

Figure 8-2 Procedure 1 of Installing USB Driver

Click “NEXT”, dialogue 8-3 will pop up. Choose “Install the software automatically (recommended)”.



Figure 8-3 Procedure 2 of Installing USB Driver

When the installation of driver is finished, user can see “USB test and measurement device” in the device manager of PC, as is shown in the following figure.

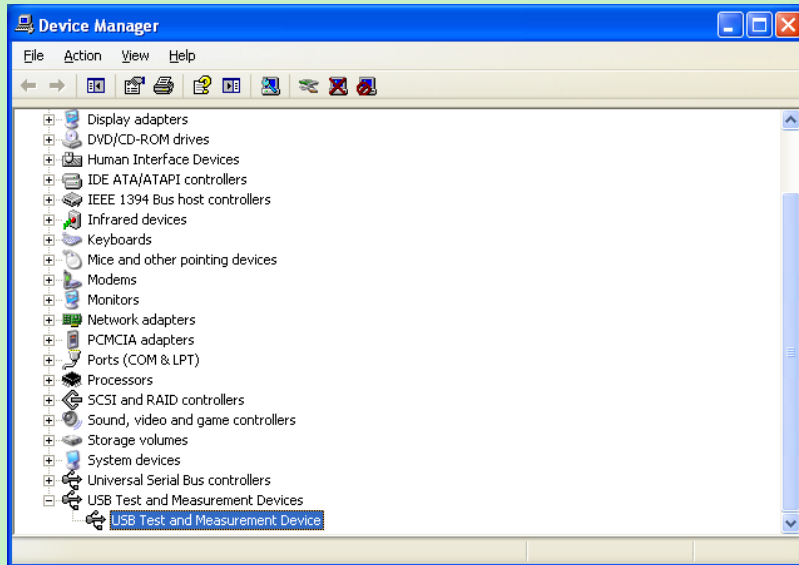

Figure 8-4 USBTMC Display of PC Device Manager

When user is using USBTMC interface, labview software can be used to access the instrument.

8.4 USBCDC Virtual Serial Port

The method of installing the driver for USBCDC is the same as the method of installing the driver with USBTMC. Once the driver is installed, the user can see "usb VCom port" in the device manager of the computer.

Now, usb VCom port acts as a serial port. When PC has no serial port, the communication software based on this serial port can be used as USB virtual serial port.

Chapter 9 SCIP Command Reference

You can log in to the company website www.tonghui.com.cn for reference.

SCPI (Standard Command for Programmable Instruments) is an ASCII-based instrument command language used in test and measurement instruments. SCPI commands are based on a hierarchical structure (also known as a tree system). In this system, related commands are grouped under a common node or root, thus forming a subsystem.

According to the command syntax, most commands (and some parameters) are represented by a mixture of uppercase and lowercase letters. Uppercase letters indicate the abbreviation of the command. For shorter program lines, you can send commands in abbreviated format. If you want better program readability, you can send long format commands.

Grammatical conventions:

```
[SOURce[1|2]:]VOLTage:UNIT {VPP|VRMS|DBM}
```

```
[SOURce[1|2]:]FREQuency:CENTer {<frequency>|MINimum|MAXimum|DEFAULT}
```

Note: Command syntax conventions:

- The braces ({ }) contain the parameter options for the given command string. Braces are not sent with the command string.
- A vertical bar (|) separates multiple parameter selections for a given command string. For example, in the above command, {VPP|VRMS|DBM} means you can specify "VPP", "VRMS" or "DBM". The bars are not sent with the command string.
- The angle brackets (< >) in the second example indicate that you must specify a value for the parameter inside the parentheses. For example, in the above syntax statement, the parameter in angle brackets is <frequency>. Angle brackets are not sent with the command string. You must specify a value for the parameter (for example "FREQ: CENT 1000") unless you choose another option (such as "FREQ: CENT MIN") that appears in the syntax.
- Some syntax elements (such as nodes and parameters) are enclosed in square brackets ([]). This means that the element is optional and can be omitted. Angle brackets are not sent with the command string. If no value is specified for the optional parameter, the instrument will choose the default value. In the above example, "SOURce[1|2]" means that you can refer to source channel 1 by "SOURce" or "SOURce1", or "SOUR1" or "SOUR". Also, since the entire SOURce node is optional (in square brackets), you can also refer to channel 1 by completely omitting the SOURce node. This is because channel 1 is the default channel for the SOURce language node. On the other hand, to refer to channel 2, you must use "SOURce2" or "SOUR2" in the program line.
- ^END: The EOI (end) signal of the IEEE-488 bus.

9.1 IEEE488.2 Common Command

Standard SCPI command:

- *IDN ●*TRG ●*RST ●* CLS
- *ESE ●*ESR ●*OPC ●*SRE
- *STB

Note: This machine mainly uses the first three commonly used instructions.

9.1.1 *IDN?

Description: Read product information.

Syntax: *IDN?

The query returns: {string 1}, {string 2}, {string 3}, {string 4} <newline><^END>

Read the data information as follows: "Manufacturer", "Product Model", "Product Serial Number", "Software Version Number"

- {string 1} Tonghui.
- {string 2} Model number (TH3311/TH3312/TH3321/TH3331).
- {string 3} Product serial number, which is the SN number.
- {string 4} Software version number.

Example:

```
*IDN?
```

9.1.2 *TRG

Description: When the instrument's trigger mode is set to bus (BUS) mode trigger, this command triggers the instrument to perform a measurement and the instrument actively returns the measurement data after performing this measurement. Return the format of the data reference: FETCh? command.

Syntax:

```
*TRG
```

9.1.3 *RST

Description: Resets the machine to the factory default state, including the value set by the parameter. Automatically restart after reset is complete.

Syntax:*RST

Example:

```
*RST
```

9.1.4 *CLS

Description: Clear the following event

Syntax: *CLS

Status Byte Register

Standard Event Status Register

Operation Status Event Register

Example:

*CLS

9.1.5 *ESE

Description: Set the Standard Event Status Enable Register.

Syntax: *ESE <?|numeric>

Parameter:

	<numeric>
Description	Set the value of the standard event status enable register.
Range	0-255
Initial value	0
Step	1

Return format: { numeric }<newline><^END>

9.1.6 *ESR

Description: Reads the value of the Standard Event Status Register. Executing this command clears the value of this register.

Syntax: *ESR?

Return format: { numeric }<newline><^END>

9.1.7 *OPC

Description: Sets the Standard Event Status Register OPC bit (bit0) after all pending operations are completed. (cannot be queried)

Syntax: *OPC

Description: Read 1 after all pending operations are completed. (only for inquiry)

Syntax: *OPC?

Return format: { 1 }<newline><^END>

9.1.8 *SRE?

Description: Set or query the value of the Service Request Enable Register.

Syntax: *SRE <numeric>

Syntax:*SRE?

Parameter:

	<numeric>
Description	Set the value of the service request enable register.
Range	0-255
Initial value	0
Step	1

Return format: { numeric }<newline><^END>

9.1.9 *STB?

Description: Query the value of the Status Byte Register.

Syntax: *STB?

The query returns: { numeric }<newline><^END>

9.2 SCPI Commands

Subsystem commands for TH33XX:

- DISPlay ●FUNction ●COMParE ●BINset
- HARMonic ●WAVE ●SYSTem ●MEMory
- TRIGger ●FETCh ●HANDle

9.2.1 DISPlay Subsystem Commands

It mainly involves switching instructions for each display page.

- Description: Control page switching and query

Syntax: :DISPlay:page {<? | PageName>}

Parameters: The value of PageName is MEASurement | COMParE | bin | HARMonic | wave | MSETup | compset | binset | harmset | HANDle | SYSTem | FLISt

Example:

:DISPlay:page ? ---- Returns the name of the page corresponding to the setting;

:DISPlay:page meas ----Enter the measurement display page (the original display A or B page);

:DISPlay:page msetup ----Enter the measurement settings page;

Special case:

:DISPlay:page meas A ----Enter the measurement display page A page

:DISPlay:page meas B ----Enter the measurement display page B page

● Description: page test data display function switch

Syntax: :DISPlay: SWITCh {? | ON | OFF}

Parameter: ON ---- Set the page refresh to display the measurement result

OFF ----Set the page does not refresh the display measurement results

Example:

:DISPlay: SWITCh ? ----Query and return the measurement data display function;

:DISPlay: SWITCh on ----Open measurement data display function;

:DISPlay: SWITCh off ---- Turn off the measurement data display function;

9.2.2 FUNCTION Subsystem Commands

It mainly involves querying and setting the relevant parameters in the measurement display page and measurement setting page.

● Description: Voltage range query and control

Syntax: :FUNCTion:VOLTage:RANGe {? | VRangeNum | auto}

:FUNCTion:VOLTage:RANGe:AUTO {? | ON | OFF}

Parameter: VRangeNum is 0/1/2/3.

Example:

:FUNCTion:VOLTage:RANGe ? ----Query and return the current voltage range;

:FUNCTion:VOLTage:RANGe 1 ----Set the voltage range to switch to Range 1;

:FUNCTion:VOLTage:RANGe auto ----Set the voltage range to switch to auto range;

:FUNCTion:VOLTage:RANGe:AUTO ? ----Query the automatic range of voltage range;

:FUNCTion:VOLTage:RANGe:AUTO ON ----Set the voltage range automatically;

:FUNCTion:VOLTage:RANGe:AUTO OFF ----Set the voltage range is not automatic;

VRangeNum	Query the return content.
	Range (automatically with AUTO-prefix)
0	75V(AUTO-75V)
1	150V
2	300V
3	600V

● Description: Current range query and control

Syntax: :FUNCTion:CURREnt:RANGe {? | IRangeNum | auto}

:FUNCTion:CURREnt:RANGe:AUTO {? | ON | OFF}

Parameters: IRangeNum is 0/1/2/3/4/5/6/7

Example:

:FUNCTion:CURREnt:RANGe ? ----Query and return the current current range;

:FUNCTion:CURREnt:RANGe 1 ----Set the current range to Range1;

:FUNCTion:CURREnt:RANGe auto ----Set the current range to auto range;

:FUNCTION:CURRENT:RANGE:AUTO ? ----Query the automatic state of the current range;

:FUNCTION:CURRENT:RANGE:AUTO ON ----Set the current range to AUTO ON;

:FUNCTION:CURRENT:RANGE:AUTO OFF ----Set the current range to AUTO OFF;

(Note: Only the TH3331 instrument has Range 7 and the other instruments do not have Range 7.)

IRangeNum	Query the return content.		
	Range (with AUTO-prefix in AUTO ON)		
	TH331X	TH3321	TH3331
0	10mA	1mA	10mA
1	30mA	3mA	30mA
2	100mA	10mA	100mA
3	400mA	40mA	400mA
4	1.5A	150mA	1A
5	5A	500mA	3A
6	20A	2A	10A
7			40A

● Description: Measurement display A page settings and query 4 measurement parameters

Syntax: :FUNCTION:{funca|funcb|funcc|funcd} {? | STR}

Parameters: funca|funcb|funcc|funcd----window parameter markers representing a/b/c/d respectively

STR is the parameter name corresponding to each window, and the value is u/i/p/pf/f/va/var/e/cfu/Cfi/upk+/upk-/ipk+/ipk-

Example:

:FUNCTION:{funca|funcb|funcc|funcd} ? ----Return the parameter name of the corresponding window

:FUNCTION:funca {u|i|p|pf|f|cfu|upk+|upk-} ----Set the measurement parameters of window A

:FUNCTION:funcb {u|i|p|cfi|ipk+|ipk-} ----Set the measurement parameters of window B

:FUNCTION:funcc {u|i|p|pf|f} ----Set the measurement parameters of window C

:FUNCTION:funcd {u|i|p|pf|f|va|var|e} ----Set the measurement parameters of window D

(Note: The optional parameters are different for each window, please write instructions according to the given example)

● Description: Test mode settings

Syntax: :FUNCTION:mode {?|rms|ac|dc}

Parameters: RMS|AC|DC ---- represent the test mode of "effective value / AC / DC"

Example:

:FUNCTION:mode ? ----Query and return the current test mode

:FUNCTION:mode rms ----Modify the test mode to the RMS test mode

(Note: In DC test mode, the parameters corresponding to 4 windows cannot be modified.)

● Description: Test synchronization settings

Syntax: :FUNCTION:SYNChro {?|SOURce/AUTO|line|VOLTage|CURRent}

Parameters: SOURce/AUTO ----Select sync signal to automatically switch

VOLTage ---- locks the sync signal on the voltage channel

CURRent ----Lock sync signal on current channel

Line ---- Lock sync signal on the power supply (power frequency signal)

Example:

:FUNCTION:SYNChro ? ----Return the current synchronization settings

:FUNCTION:SYNChro SOURce ----Modify the sync line of the setup test

:FUNCTION:SYNChro AUTO ---- Function as above

:FUNCTION:SYNChro VOLTage ---- Synchronous locking of the voltage channel

:FUNCTION:SYNChro CURRent ----Synchronous locking of the current channel

:FUNCTION:SYNChro LINE ---- Synchronous locking the power frequency channel

● Description: Test line 5kHz filter function setting

Syntax: :FUNCTION:linefilt {?|ON|OFF}

Parameters: ON/OFF ---- respectively represent the "ON/OFF" status of the test filtering function

Example:

:FUNCTION:linefilt ? ----Query and return the current sync line

:FUNCTION:linefilt {ON|OFF} ----Modify the setup testing 5kHz filtering function

● Description: The settings of the average number of measurements

Syntax: :FUNCTION:avg {?|<NUM>}

Parameters: NUM takes values from 1 to 32

Example:

:FUNCTION:avg ? ----Query and return the current average number of measurements

:FUNCTION:avg 6 ----Modify the average number of measurements to 6 times

● Description: Set the energy integral control method

Syntax: :FUNCTION:ecmode {?|MAN|CONTInue}

Parameters: MAN | CONTInue respectively stands for "Manual / Continue" control

Example:

:FUNCTION: ecmode? ----Query and return the current energy integral control mode

:FUNCTION: ecmode {MAN|CONTInue} ----Set the energy integration control mode

● Description: Set the energy integral control method

Syntax: :FUNCTION:etime {?|< ehour,emin,esec>}

Parameters: ehour, emin, esec represent "hour, minute, second" control

ehour value range: 0~9999

emin, esec value range: 0~59

Example:

:FUNCTION: etime? ----Query and return the current energy integration limit time

:FUNCTION: etime 1,22,33 ----Modify the setting energy integration limit time to 1 hour 22 minutes 33 seconds

● Description: Control energy integration running status

Syntax: :FUNCTION:ENERgy {?|run | stop | reset}

Parameters:

run ---- start running

Stop ---- stop running

Reset ---- cumulative result and cumulative time reset

Example:

:FUNCTION: ENERgy ? ----Query and return the current energy integration running status

:FUNCTION: ENERgy run ----Start running energy score

:FUNCTION: ENERgy stop----Stop running energy score

:FUNCTION: ENERgy reset----Reset energy integration result and timing status

9.2.3 COMPare Subsystem Commands

It mainly involves querying and modifying the related parameters in the comparison display page and the comparison setting page.

● Description: Set the comparison function main switch

Syntax: :COMPare:SWITCh {?|ON|OFF}

Parameters: ON|OFF stands for "ON/OFF"

Example:

:COMPare:SWITCh ? ----Query and return the current comparison switch status

:COMPare:SWITCh {ON|OFF} ----Modify the setting of comparison switch status

● Description: Set the comparison beeper control

Syntax: :COMPare: BEEPer{?|NG|GD|OFF}

Parameters: NG|GD|OFF stands for "bad/good/off"

Example:

:COMPare: BEEPer? ----Query and return the current comparison status

:COMPare: BEEPer{NG|GD|OFF } ----Modify the setting of comparison beeper control state

● Description: parameter settings of the comparison output channel

Syntax: :COMPare:HANDle[1|2|3|4] {?|STR}

Parameters: HANDle[1|2|3|4] represents the output of 4 channels;

STR is the channel optional parameter name, which is:

u / upk+ / upk- / uthd

I / ipk+ / ipk- / ithd

P / va / var

PF / f / cfi

Example:

:COMPare:HANDle2 ? ----Query and return the controlled parameters of output channel 2

:COMPare:HANDle3 PF ----Modify the setting controlled parameter of output channel 3 to PF.

(Note: Since some instruments do not have harmonic analysis function, there is no corresponding Uthd and Ithd option.)

- Description: Set the upper and lower limits of the comparison parameters and the corresponding independent switch states.

Syntax: :COMPare:PARAMeter:{ STR }:<LOW | HIGH> {? | float}
:COMPare:PARAMeter:{ STR }: SWITCh {? | ON | OFF}

Parameters: STR is the parameter name corresponding to each channel. The value is:

u / upk+ / upk- / uthd

I / ipk+ / ipk- / ithd

P / va / var

PF / f / cfi;

LOW / HIGH represents the lower or upper limit respectively;

Float represents the floating point data size;

SWITCh represents an independent comparison switch corresponding to the selected parameter;

ON/OFF represents the independent comparison switch state corresponding to the selected parameter;

Example:

:COMPare:PARAMeter:u:LOW ? ----Return the lower limit of the voltage comparison

:COMPare:PARAMeter:u: SWITCh ?----Return voltage comparison independent switch state

:COMPare:PARAMeter:u:HIGH 600.6 ----Set the upper limit of voltage comparison to 600.6V

:COMPare:PARAMeter:u: SWITCh on ----Turn on the independent switch for voltage comparison

(Note: Since some instruments do not have harmonic analysis function, there is no corresponding Uthd/Ithd option for STR.)

- Description: Clear the upper and lower limits of all parameters and independent switch settings

Syntax: :COMPare clear

parameter:

Example:::COMPare clear ---- Return OK after successful execution

9.2.4 BINset Subsystem Commands

It mainly involves querying and modifying related parameters in the bin display page and the bin setting page.

- Description: Set the bin mode

Syntax: :BINset:BINMode {?|COMPare|BIN}

Parameters: COMPare|BIN stands for "single bin comparison/bin comparison"

Example:

:BINset:BINMode ? ----Query and return the current bin mode

:BINset:BINMode BIN ----Modify the bin mode as BIN mode

- Description: Set bin comparison beeper control

Syntax: :BINset:BEEPer {?|NG|GD|OFF}

Parameters: NG|GD|OFF stands for "bad/good/off"

Example:

:BINset:BEEPer ? ----Query and return the current bin comparison beeper status

:BINset:BEEPer NG ----Modify the setting bin comparison beeper control status to NG

● Description: Set bin comparison function switch

Syntax: :BINset:SWITCh {?|ON|OFF}

Parameters: ON|OFF stands for "ON/OFF"

Example:

:BINset:SWITCh ? ----Query and return the current bin comparison switch status

:BINset:SWITCh ON ----Modify the setting bin comparison switch status to ON

● Description: Set the bin number in the single bin comparison state

Syntax: :BINset:LOADbin {?|<NUM>}

Parameter: NUM value range 1~6 represents the bin number of the 6 groups of bins

Example:

:BINset:LOADbin ? ----Query and return the currently loaded bin number

:BINset:LOADbin 1 ----Modify the setting single bin comparison range to the data under BIN 1

● Description: Set the bin parameter

Syntax: :BINset:PARAMeter {?|STR}

Parameters: STR is the parameter name participating in the bin sorting. The value is:

u / upk+ / upk- / uthd

I / ipk+ / ipk- / ithd

P / va / var

PF / f / cfi;

Example:

:BINset:PARAMeter ? ----Query and return the controlled parameters of output channel 2

:BINset:PARAMeter pf ----Modify the controlled parameter of output channel 3 to PF

(Note: Since some instruments do not have harmonic analysis function, there is no corresponding Uthd and Ithd option)

● Description: Set the data mode corresponding to the upper and lower limit data of the bin comparison.

Syntax: :BINset:DATAMode {?|ABS|PERcent}

Parameters: ABS|PERcent means "absolute value mode / percentage mode"

Example:

:BINset:DATAMode ? ----Query and return the data mode of the upper and lower limits of the bin comparison.

:BINset:DATAMode ABS ----Modify the data mode of the upper and lower limits of the bin comparison to the absolute value mode

(Note: The ABS here is the same as the rest of the instrument, it does not mean the true absolute value, but only the real number distinguishing from the percentage, the data involved will have positive and negative points.)

- Description: Set the nominal value of the upper and lower limit data of bin comparison in percentage mode

Syntax: :BINset:NORMal {?|float}

Parameters: float represents a floating point data size (real number with realistic significance corresponding to the bin sorting parameter)

Example:

:BINset:NORMal ? ----Query and return the current nominal value data size

:BINset:NORMal 220.2 ----Modify the the current nominal value data size to 220.2

- Description: Set the parameter settings of the comparison output channel

Syntax: :BINset:bin{<1|2|3|4|5|6>} {<lowabs | highabs | lower | higher | low | high>} {? | float}

Parameters: bin[1|2|3|4|5|6] respectively represent the 6 sets of data numbers for bin sorting;

Lowabs | highabs represents the upper and lower limit data size in absolute value mode;

Lower | higher indicates the upper and lower limit data size in percentage mode, and the corresponding size ranges from 0.00 to 100.0.

Low | high means to set the data in the current data mode,

Float represents the size of the floating point data;

Example:

:BINset:bin1:lowabs ? ----Return the lower limit value in the absolute value mode for BIN 1

:BINset:bin1:higher ? ----Returns the upper limit value in the percentage mode for BIN 1

:BINset:bin1:high ? ----Returns the upper limit of the current data mode for BIN 1

:BINset:bin1 lowabs 99.99 ----Set the lower limit of the absolute value mode for BIN 1

:BINset:bin1 higher 99.99 ----Set the upper limit in the percentage mode for BIN 1

:BINset:bin1 high 88.88 ----Set the upper limit of the current mode for BIN 1

- Description: Clear the upper and lower limit setting data of each bin for the current bin sorting parameter, including the nominal value data.

Syntax: :BINset clear

Parameters:

Example: BINset clear ---- Return OK after execution

9.2.5 HARMonic Subsystem Commands

- Description: Set the harmonic analysis function to analyze the switch status

Syntax::HARMonic:SWITCh {?|ON|OFF}

Parameters: ON|OFF stands for "ON/OFF"

Example:

:HARMonic:SWITCh ? ----Query and return the current harmonic analysis switch status

:HARMonic:SWITCh ON ----Modify the setting harmonic analysis switch status to ON

- Description: Set the harmonic analysis parameter item

Syntax::HARMonic:item {?|VOLTage|CURRent|all}

Parameter: VOLTage|CURRent|all means to analyze harmonic data of “voltage/current/voltage

and current”

Example:

:HARMonic:item ? ----Query and return the parameters of the current harmonic analysis

:HARMonic:item VOLTage ----Modify the setting harmonic analysis parameter item to voltage

:HARMonic:item CURRent ----Modify the setting harmonic analysis parameter item to current

:HARMonic:item all ----Modify the harmonic analysis parameter item to voltage and current

● Description: Set the calculation standard for harmonic analysis data

Syntax::HARMonic:calstd { ?|IEC|CSA }

Parameters: IEC|CSA stands for two calculation standards of "International Electrotechnical Commission / Canadian Standards Association"

Example:

:HARMonic:calstd ? ----Query and return the calculation standard of the current harmonic analysis data

:HARMonic: calstd IEC ----Modify the calculation standard for harmonic analysis as IEC standard

● Description: Set the display form of the harmonic analysis result

Syntax::HARMonic:form { ?|COMMon|list|bar }

Parameters: COMMON|list|bar means three display forms of "normal / list / histogram"

Example:

:HARMonic:form ? ----Query and return the display form of the current harmonic analysis result

:HARMonic:form list ----Modify the display of harmonic analysis results as a list form

● Description: Set the data mode corresponding to the harmonic analysis data

Syntax::HARMonic:DATAmode { ?|ABS|PERcent }

Parameters: ABS|PERcent means "absolute value mode / percentage mode"

Example:

:HARMonic:DATAmode ? ----Query and return the data mode of the current harmonic analysis

:HARMonic:DATAmode PERcent ----Modify the data mode of setting harmonic analysis to percentage mode

● Description: Set the up and down direction key response of the harmonic display page

Syntax::HARMonic:key { up|down }

Parameters: up|down means "up/down"

Example:

:HARMonic:key up ----Upward direction key response effect of the harmonic display page

:HARMonic:key down ----Downward direction key response effect of the harmonic display page

9.2.6 WAVE Subsystem Commands

● Description: Set the waveform display parameter item

Syntax: :wave:item { ?|VOLTage|CURRent|all }

Parameters: VOLTage|CURRent|all respectively represent the waveforms for analyzing "voltage/current/voltage and current"

Example:

:wave:item ? ----Query and return the parameter of the current waveform

:wave:item VOLTage ----Modify the setting waveform parameter item to voltage

:wave:item CURRent ----Modify the setting waveform parameter item as current

:wave:item all ----Modify the setting waveform parameters for voltage and current

9.2.7 SYSTem Subsystem Commands

● Description: Set button beeper switch

Syntax: :SYSTem:BEEPer {?|ON|OFF}

Parameters: ON|OFF stands for "ON/OFF"

Example:

:SYSTem: BEEPer ? ----Query and return the current button beeper switch status

:SYSTem: BEEPer {ON|OFF} ----Modify the setting button beeper switch control status "ON or OFF"

● Description: Perform system software upgrade operations

Syntax: :SYSTem:update

parameter:

Example:

:SYSTem:update ----Execute system software upgrade operation

● Description: Set the system language

Syntax: :SYSTem:LANGUage {?|ENGLISH|CHinese}

Parameters: English | CHinese stands for "English/Chinese"

Example:

:SYSTem:LANGUage ? ----Query and return the current system language

:SYSTem:LANGUage ch ----Modify the setting system language to Chinese

● Description: Set the system date----year

Syntax: :SYSTem:year {? | NUM}

Parameter: NUM value range 11~99

Example:

:SYSTem:year 17 ----Modify the setting date to 2017

● Description: Set the system date----month

Syntax: :SYSTem:MONth {? | NUM}

Parameter: NUM value range 1~12

Example:

:SYSTem:MONth 01 ----Modify the setting date to January

● Description: Set the system date----day

Syntax: :SYSTem:date {? | NUM}

Parameter: NUM value range 1~31

Example:

:SYSTem:date 01 ----Modify the setting date to 01

● Description: Set the system time ---- hour

Syntax: :SYSTem:hour {? | NUM}

Parameter: NUM value range 0~23

Example:

:SYSTem:hour 12 ----Modify the setting date to 12 hours

● Description: Set the system time----minute

Syntax: :SYSTem:MINute {? | NUM}

Parameter: NUM value range 0~59

Example:

:SYSTem:min 12 ----Modify the setting date to 12 minutes

● Description: Set the system time ---- second

Syntax: :SYSTem:SECond {? | NUM}

Parameter: NUM value range 0~59

Example:

:SYSTem:sec 12 ----Modify the setting date to 12 seconds

9.2.8 MEMory Subsystem Commands

● Description: Load the internal settings file

Syntax: :MEMory:load NUM

Parameter: NUM value range 1~102

Example:

:MEMory:load 1 ----Load the setting file No. 1 in the internal file list

● Description: Save the current parameter settings to an internal file

Syntax: :MEMory:save {NUM,Fname}

Parameter: NUM value range 1~102

The value of Fname is a string of characters, which is a reasonable file name. The length is no more than 8. If the file name has a suffix of .STA, the length is no more than 12 characters.

Example:

:MEMory:store 1,abc ----Save the current setting of the parameter to the file number 1 with the file name "ABC.STA"

:MEMory:store 1,abc.STA---- the same as above

9.2.9 TRIGger Subsystem Commands

● Description: Perform a bus trigger test

Syntax::TRIGger[:IMMEDIATE]

Parameter: [:IMMediate] can be omitted

Example:

:TRIGger or

:TRIGger:IMMediate

● Description: Set the trigger mode

Syntax::TRIGger:SOURce {? | INTernal | EXTernal | BUS | MAN}

Parameter: INTernal | EXTernal | BUS | MAN means "internal/external/bus/manual"

Example:

:TRIGger:SOURce ? ----Query and return the measurement trigger mode of the current system

:TRIGger:SOURce BUS ----Set the measurement trigger mode to bus trigger

● Description: Set the trigger delay time

Syntax::TRIGger:DELay {? | min | max | NUM}

Parameter: min means the minimum value, that is, the minimum delay time is 0s.

Max means the maximum value, that is, the maximum delay time is 60s.

NUM ranges from 0.000 to 60.00

Example:

:TRIGger:DELay ? ----Query and return the measurement trigger delay time of the current system

:TRIGger:DELay min ----Set the measurement trigger delay time to the minimum delay 0s

:TRIGger:DELay max ----Set the measurement trigger delay time to the minimum delay of 60s

:TRIGger:DELay 0.001 ----Set the measurement trigger delay time to 1ms

9.2.10 FETCh Subsystem Commands

● Description: Query and return relevant measurement data of the current page

Syntax: :FETCh?

Parameter:

Example:

:FETCh? ---- Measurement display page A returns the measurement results of 4 windows in turn;

---- Measurement display page B returns all displayed results in turn;

----Compare display page returns the test results and comparison results of all displayed parameters;

----BIN display page returns the test results and bin sorting results of the selected bin parameters;

----Harmonic display page returns the calculation results of Uthd and Ithd;

----Waveform display page returns the same as the measurement display B page;

Note: the order of the parameters returned by the measurement display B page is:

volt, curr, power, pf, freq, va, var, energy, cfu, cfi, upk+, upk-, ipk+, ipk-, upp, ipp, a total of 16 parameters ;

Compare result parameters return order:

Voltage U, voltage positive peak UPK+, voltage negative peak UPK-, [voltage total harmonic UTHD], Current I, current positive peak IPK+, current negative peak IPK-, [current total harmonic ITHD], Active power P, total power VA, virtual work VAR, Power factor PF, frequency

Freq, current peak factor CFi.

Bin sorting result return content: the test result, the bin comparison result.

● Description: Measurement data is automatically returned to the settings

Syntax: :FETCh:auto {? | ON | OFF}

Parameters: ON ---- set the data automatically returns to the host computer after each test, the return data is the same as the above syntax;

OFF ----Set to turn off the automatic return function of measurement data;

Example:

:FETCh:auto ? ----Query and return the current automatic data return function switch status

:FETCh:auto on ----Set the data to automatically return to the host computer after each test

:FETCh:auto off ----Set to turn off the measurement data auto return function

● Description: Query 16 basic measurement results, which is equivalent to the query result of measurement display B, you use this command to query the basic data in any page.

Syntax::FETCh all

Returns: parameter order: volt, curr, power, pf, freq, va, var, energy, cfu, cfi, upk+, upk-, ipk+, ipk-, upp, ipp, a total of 16 parameters;

Example:

:FETCh all ----Query the test results in the current test mode, that is, the above 16;

● Description: Query the measurement result of the specified parameter

Syntax::FETCh {VOLTage | CURRent | ...}

Parameters: See the returned data order introduction of the measurement display B page, the listed parameters can be entered as optional parameters. The parameters can also be directly sent the corresponding values 0~15.

Example:

:FETCh CURRent ----Query the test result of the current in the current test mode

:FETCh 1 ----Features are equivalent to the above

● Description: Query the harmonic analysis data of the specified number of times

Syntax::FETCh:HARMonic:{VOLTage | CURRent} {NUM | ALL | "n0,n1"}

Parameters: VOLTage | CURRent----Two choices, indicating the query of harmonics of voltage or current

NUM ---- Specify the number of single harmonic to be queried

ALL ----Query all harmonic data, ie 2~50 harmonic data

"n0,n1" ----Query the harmonic data of the specified number of intervals, n0<=n1, and the value ranges from 2 to 50.

(Note: you need to send double quotes together)

Example:

:FETCh:HARMonic:VOLTage 2 ----Return 2 times of voltage harmonic data

:FETCh:HARMonic:VOLTage all ----Return 2~50 times of all voltage harmonic data

:FETCh:HARMonic:VOLTage "6,9"----Return 6~9 times of voltage harmonic data

:FETCh:HARMonic:CURRent 3 ----Return 3 times of current harmonic data

:FETCh:HARMonic:CURRent all ----Return 2~50 times of all current harmonic data

:FETCh:HARMonic:CURRent "2,9"----Return 2~9 times of current harmonic data

● Description: Query the composition of the total harmonics of voltage and current

Syntax: :FETCh:HARMonic THD

Parameters:

Example:

:FETCh:HARM THD ----Return total voltage and current harmonics

● Description: Query voltage or current waveform data

Syntax::FETCh:wave {VOLTage | CURRent}

Parameters: VOLTage | CURRent----Two choices, which indicates querying the waveform data of the voltage or current.

Example:

:FETCh:wave VOLTage ----Query the voltage waveform data

:FETCh:wave CURRent ----Query the current waveform data

Note: Since the waveform data is relatively more, only 128 points of waveform data are returned here. The source of the 128-point data is the point data of the even-point position obtained by sampling in one cycle, which is enough to describe the waveform.

● Description: Query the comparison results of comparable parameters

Syntax: :FETCh COMPare

Parameters:

Example:

:FETCh COMPare ----Return the comparison result

● Description: Query the bin sorting result of the current parameter

Syntax::FETCh BIN

Parameters:

Example:

:FETCh BIN ----Return the bin sorting result

9.2.11 HANDLE Subsystem Commands

● Description: Query and return the control mode of Handle output signal

Syntax::HANDLe:HANDLe[1/2/3/4]:FUNCTion {? | failcont | passcont | failpulse | Passpulse | off}

or :HANDLe:HANDLe[1/2/3/4]:FUNCTion {? | f2 | f3 | f4 | f5 | f6}

Parameter: HANDLe[1/2/3/4] indicates the corresponding 4 output channels

Failcont | passcont it means "failed conduction / qualified conduction"

Failpulse | passpulse it means "failed pulse / qualified pulse"

Off it means to turn off the output function of the corresponding channel

F2 | f3 | f4 | f5 | f6 One-to-one correspondence between the position and the above function, and one-to-one correspondence with the corresponding soft key position

Example:

:HANDle:HANDle1:FUNction ? ---- Query and return the function control mode corresponding to channel 1.

:HANDle:HANDle1:FUNction failcont ----Set the output control of channel 1 to unqualified conduction.

:HANDle:HANDle2:FUNction passcont----Set the output control of channel 2 to qualified conduction.

:HANDle:HANDle3:FUNction failpulse----Set the output control of channel 3 to unqualified pulse.

:HANDle:HANDle4:FUNction passpulse----Set the output control of channel 4 to qualified pulse.

:HANDle:HANDle1:FUNction off ----Set the output control of channel 1 to OFF.

9.3 ModeBus commands

9.3.1 Command format

Writing the command

➤ Sending format

Instrument address	Function code	High address	Low address	High bytes	Low bytes	Number of data	Data byte 1	Data byte n	CRC Low	CRC High
--------------------	---------------	--------------	-------------	------------	-----------	----------------	-------------	-------	-------------	---------	----------

➤ Return format

Instrument address	Function code	High address	Low address	High bytes	Low bytes	CRC Low	CRC High
--------------------	---------------	--------------	-------------	------------	-----------	---------	----------

a) Instrument address

It refers to the local address of the instrument, which can be set in the bus address of the instrument's system setting interface. The value range is: 1~31

b) Function code: 0x0F

This command can write one data or multiple data, so its code is: 0x0F

c) High address and low address

It refers to the storage address of the data in the instrument, which can be a real storage address or a mapped address.

d) High bytes and low bytes

It refers to the total number of bytes written for this operation.

e) Number of data

It refers to the total number of data written by this operation. If it is to write one data, the value is: 0x01

f) Data byte 1~data byte n

Write these data content to the instrument.

g) CRC high and CRC low

CRC 16-bit check, we use the look-up table method for CRC check.

➤ Example: The specific instruction and function setting relationship is detailed in the Appendix Table ModeBus command function comparison table (Section 9.3.3);

Set the voltage range, set to Range 2 (ie 300V), the storage address of voltage range parameter in the instrument is 0x0003, the instrument bus address is 8.

Then the command is:

0x08	0x0F	0x01	0x03	0x00	0x01	0x01	0x02	2B	3C
------	------	------	------	------	------	------	------	----	----

Where, Data byte 1~data byte 4 are the values of the frequency, the type is float, which is 4 bytes.

The return information is as follows:

0x08	0x0F	0x01	0x03	0x00	0x01	0x64	0x92
------	------	------	------	------	------	------	------

Reading the command

➤ Sending format

Instrument address	Function code	High address	Low address	High bytes	Low bytes	CRC Low	CRC High
--------------------	---------------	--------------	-------------	------------	-----------	---------	----------

➤ Return format

Instrument address	Function code	High address	Low address	High bytes	Low bytes	Number of data	Data byte 1	Data byte n	CRC Low	CRC High
--------------------	---------------	--------------	-------------	------------	-----------	----------------	-------------	-------	-------------	---------	----------

The function code is: 0x03

➤ Example: The specific instruction and function setting relationship is detailed in the Appendix Table ModeBus command function comparison table (Section 9.3.3);

To read the test value of the voltage in the current mode, the storage address is 0x00A0, the instrument number is 8.

Then the command is:

0x08	0x03	0x00	0xA0	0x00	0x04	0x44	0xB2
------	------	------	------	------	------	------	------

The return information is as follows:

0x08	0x03	0x00	0xA0	0x00	0x04	Data byte 1	Data byte n	CRC Low	CRC High
------	------	------	------	------	------	-------------	-------	-------------	---------	----------

9.3.2 CRC16 calculation method - look-up table method

a) First define two 256-byte checklists

// CRC high byte value table

```
const BYTE chCRCHTalbe[] = // CRC high byte value table
{
0x00, 0xC1, 0x81, 0x40, 0x01, 0xC0, 0x80, 0x41, 0x01, 0xC0, 0x80, 0x41,
0x00, 0xC1, 0x81, 0x40, 0x01, 0xC0, 0x80, 0x41, 0x00, 0xC1, 0x81, 0x40,
0x00, 0xC1, 0x81, 0x40, 0x01, 0xC0, 0x80, 0x41, 0x01, 0xC0, 0x80, 0x41,
0x00, 0xC1, 0x81, 0x40, 0x00, 0xC1, 0x81, 0x40, 0x01, 0xC0, 0x80, 0x41,
0x00, 0xC1, 0x81, 0x40, 0x01, 0xC0, 0x80, 0x41, 0x01, 0xC0, 0x80, 0x41,
0x00, 0xC1, 0x81, 0x40, 0x01, 0xC0, 0x80, 0x41, 0x00, 0xC1, 0x81, 0x40,
```

```

0x00, 0xC1, 0x81, 0x40, 0x01, 0xC0, 0x80, 0x41, 0x00, 0xC1, 0x81, 0x40,
0x01, 0xC0, 0x80, 0x41, 0x01, 0xC0, 0x80, 0x41, 0x00, 0xC1, 0x81, 0x40,
0x00, 0xC1, 0x81, 0x40, 0x01, 0xC0, 0x80, 0x41, 0x01, 0xC0, 0x80, 0x41,
0x00, 0xC1, 0x81, 0x40, 0x01, 0xC0, 0x80, 0x41, 0x00, 0xC1, 0x81, 0x40,
0x00, 0xC1, 0x81, 0x40, 0x01, 0xC0, 0x80, 0x41, 0x01, 0xC0, 0x80, 0x41,
0x00, 0xC1, 0x81, 0x40, 0x00, 0xC1, 0x81, 0x40, 0x01, 0xC0, 0x80, 0x41,
0x01, 0xC0, 0x80, 0x41, 0x00, 0xC1, 0x81, 0x40, 0x01, 0xC0, 0x80, 0x41,
0x00, 0xC1, 0x81, 0x40, 0x00, 0xC1, 0x81, 0x40, 0x01, 0xC0, 0x80, 0x41,
0x00, 0xC1, 0x81, 0x40, 0x01, 0xC0, 0x80, 0x41, 0x01, 0xC0, 0x80, 0x41,
0x00, 0xC1, 0x81, 0x40, 0x01, 0xC0, 0x80, 0x41, 0x00, 0xC1, 0x81, 0x40,
0x00, 0xC1, 0x81, 0x40, 0x01, 0xC0, 0x80, 0x41, 0x01, 0xC0, 0x80, 0x41,
0x00, 0xC1, 0x81, 0x40, 0x01, 0xC0, 0x80, 0x41, 0x01, 0xC0, 0x80, 0x41,
0x00, 0xC1, 0x81, 0x40, 0x01, 0xC0, 0x80, 0x41, 0x01, 0xC0, 0x80, 0x41,
0x00, 0xC1, 0x81, 0x40
};

```

// CRC low byte value table

```

const BYTE chCRCLTable[] =
{
0x00, 0xC0, 0xC1, 0x01, 0xC3, 0x03, 0x02, 0xC2, 0xC6, 0x06, 0x07, 0xC7,
0x05, 0xC5, 0xC4, 0x04, 0xCC, 0x0C, 0x0D, 0xCD, 0x0F, 0xCF, 0xCE, 0x0E,
0x0A, 0xCA, 0xCB, 0x0B, 0xC9, 0x09, 0x08, 0xC8, 0xD8, 0x18, 0x19, 0xD9,
0x1B, 0xDB, 0xDA, 0x1A, 0x1E, 0xDE, 0xDF, 0x1F, 0xDD, 0x1D, 0x1C, 0xDC,
0x14, 0xD4, 0xD5, 0x15, 0xD7, 0x17, 0x16, 0xD6, 0xD2, 0x12, 0x13, 0xD3,
0x11, 0xD1, 0xD0, 0x10, 0xF0, 0x30, 0x31, 0xF1, 0x33, 0xF3, 0xF2, 0x32,
0x36, 0xF6, 0xF7, 0x37, 0xF5, 0x35, 0x34, 0xF4, 0x3C, 0xFC, 0xFD, 0x3D,
0xFF, 0x3F, 0x3E, 0xFE, 0xFA, 0x3A, 0x3B, 0xFB, 0x39, 0xF9, 0xF8, 0x38,
0x28, 0xE8, 0xE9, 0x29, 0xEB, 0x2B, 0x2A, 0xEA, 0xEE, 0x2E, 0x2F, 0xEF,
0x2D, 0xED, 0xEC, 0x2C, 0xE4, 0x24, 0x25, 0xE5, 0x27, 0xE7, 0xE6, 0x26,
0x22, 0xE2, 0xE3, 0x23, 0xE1, 0x21, 0x20, 0xE0, 0xA0, 0x60, 0x61, 0xA1,
0x63, 0xA3, 0xA2, 0x62, 0x66, 0xA6, 0xA7, 0x67, 0xA5, 0x65, 0x64, 0xA4,
0x6C, 0xAC, 0xAD, 0x6D, 0xAF, 0x6F, 0x6E, 0xAE, 0xAA, 0x6A, 0x6B, 0xAB,
0x69, 0xA9, 0xA8, 0x68, 0x78, 0xB8, 0xB9, 0x79, 0xBB, 0x7B, 0x7A, 0xBA,
0xBE, 0x7E, 0x7F, 0xBF, 0x7D, 0xBD, 0xBC, 0x7C, 0xB4, 0x74, 0x75, 0xB5,
0x77, 0xB7, 0xB6, 0x76, 0x72, 0xB2, 0xB3, 0x73, 0xB1, 0x71, 0x70, 0xB0,
0x50, 0x90, 0x91, 0x51, 0x93, 0x53, 0x52, 0x92, 0x96, 0x56, 0x57, 0x97,
0x55, 0x95, 0x94, 0x54, 0x9C, 0x5C, 0x5D, 0x9D, 0x5F, 0x9F, 0x9E, 0x5E,
0x5A, 0x9A, 0x9B, 0x5B, 0x99, 0x59, 0x58, 0x98, 0x88, 0x48, 0x49, 0x89,
0x4B, 0x8B, 0x8A, 0x4A, 0x4E, 0x8E, 0x8F, 0x4F, 0x8D, 0x4D, 0x4C, 0x8C,
0x44, 0x84, 0x85, 0x45, 0x87, 0x47, 0x46, 0x86, 0x82, 0x42, 0x43, 0x83,
0x41, 0x81, 0x80, 0x40
};

```

b) then calculate

```
WORD CRC16(BYTE* pchMsg, WORD wDataLen)
{
    BYTE chCRCHi = 0xFF; // High CRC byte initialization
    BYTE chCRCLo = 0xFF; // Low CRC byte initialization
    WORD wIndex;        // Index in the CRC loop
while (wDataLen--)
    {
        // Calculate CRC
        wIndex = chCRCLo ^ *pchMsg++;
        chCRCLo = chCRCHi ^ chCRCHTalbe[wIndex];
        chCRCHi = chCRCLTalbe[wIndex];
    }
return ((chCRCHi << 8) | chCRCLo);
}
```

9.3.3 Command function comparison table

Instrument bus address	Function code	Command address	Number of data bytes	Data Number	Data byte	Instruction function meaning
Instrument address	Read/write	High + low	High + low	Data Number	The setting value corresponding to the address	
1~31	R	0x0000				Query the instrument IDN
	R/W	0x0001	0x0001	1	0x01	Turn on the data display function
					0x00	Turn off the data display function
	R/W	0x0002	0x0001	1	0x00	Measurement display A
0x01					Measurement display B	
0x02					Compare display	
0x03					BIN display	
0x04					Harmonic display	
0x05					Waveform display	
0x06					Measurement setup	
0x07					Compare setup	
0x08					BIN setup	
0x09					Harmonic setup	
R/W	0x0003	0x0001	1	0x0A	Handle setup	
				0x0B	System setup	
				0x0C	Internal file display	
				<0x00~0x03>	Voltage range	

R/W	0x0004	0x0001	1	0x00 0x01	Voltage range AUTO ON Voltage range AUTO OFF
R/W	0x0005	0x0001	1	<0x00-0x07 >	Current range
R/W	0x0006	0x0001	1	0x00 0x01	Current range OFF Current range ON
R/W	0x0007	0x0001	1	0x00 0x01 0x02 0x03 0x04 0x08 0x0B 0x0C	FUNC1 measurement function is set to: U FUNC1 measurement function is set to: I FUNC1 measurement function is set to: P FUNC1 measurement function is set to: PF FUNC1 measurement function is set to: F FUNC1 measurement function is set to: Cfu FUNC1 measurement function is set to: Upk+ FUNC1 measurement function is set to: Upk-
R/W	0x0008	0x0001	1	0x00 0x01 0x02 0x09 0x0D 0x0E	FUNC2 measurement function is set to: U FUNC2 measurement function is set to: I FUNC2 measurement function is set to: P FUNC2 measurement function is set to: Cfi FUNC2 measurement function is set to: Ipk+ FUNC2 measurement function is set to: Ipk-
R/W	0x0009	0x0001	1	0x00 0x01 0x02 0x03 0x04	FUNC3 measurement function is set to: U FUNC3 measurement function is set to: I FUNC3 measurement function is set to: P FUNC3 measurement function is set to: PF FUNC3 measurement function is set to: F
R/W	0x000A	0x0001	1	0x00 0x01 0x02 0x03 0x04 0x05 0x06 0x07	FUNC4 measurement function is set to: U FUNC4 measurement function is set to: I FUNC4 measurement function is set to: P FUNC4 measurement function is set to: PF FUNC4 measurement function is set to: F FUNC4 measurement function is set to: VA FUNC4 measurement function is set to: VAR FUNC4 measurement function is set to: E
R/W	0x000B	0x0001	1	0x00 0x01 0x02	Set the measurement mode to valid value Set the measurement mode to AC Set the measurement mode to DC
R/W	0x000C	0x0001	1	0x03 0x01 0x02 0x00	Set the synchronization source to the line power supply Set the synchronization source to the voltage signal Set the synchronization source to the current signal Set the synchronization source to AUTO
R/W	0x000D	0x0001	1	0x01	Set the sampling line 5kHz filter to ON

				0x00	Set the sampling line filter to OFF
R/W	0x000E	0x0001	1	0x01-0x20	Set the average number of times required
R/W	0x000F	0x0001	1	0x00 0x01	Set the energy integration to manual control Set the energy integration to auto control
R/W	0x0010	0x0004	3	int+char+char	Set the energy integration time interval (int, char minute, char second)
R/W	0x0020	0x0001	1	0x01 0x00	Set the compare function switch to ON Set the compare function switch to OFF
R/W	0x0021	0x0001	1	0x01 0x02 0x00	Set the compare buzzer to beeper when it fails Set the compare buzzer to beeper when it passes Turn off the compare buzzer sound
R/W	0x0022 0x0023 0x0024 0x0025	0x0001	1	<0x00~0x0D> <0x00~0x0D> <0x00~0x0D> <0x00~0x0D>	Set the parameters corresponding to the output port. Parameters 0x00~0x0D respectively indicates: U/Upk+/Upk-/Uthd/I/Ipk+/Ipk-/Ithd/P/VA/VAR/PF/F/cfi
R/W	0x0026 0x0027 0x0028 0x0029 0x002A 0x002B 0x002C 0x002D 0x002E 0x002F 0x0030 0x0031 0x0032 0x0033	0x0009	3	float+float+char	Set the lower limit, upper limit and independent switch corresponding to the comparison parameters
R/W	0x0040	0x0001	1	0x00 0x01	Set the bin sorting mode to single bin mode Set the bin sorting mode to BIN mode
R/W	0x0041	0x0001	1	0x01 0x02 0x00	Set the bin buzzer to beeper when it fails Set the bin buzzer to beeper when it passes Turn off the bin buzzer sound
R/W	0x0042	0x0001	1	0x01 0x00	Turn ON the BIN sorting switch Turn OFF the BIN sorting switch
R/W	0x0043	0x0001	1	<0x00~0x05>	Set the BIN number BIN1~BIN6 loaded in single bin mode

R/W	0x0044	0x0001	1	<0x00~0x0D>	Set the bin parameters. Parameters 0x00~0x0D respectively indicates: U/Upk+/Upk-/Uthd/I/Ipk+/Ipk-/Ithd/P/VA/VAR /PF/F/cfi
R/W	0x0045	0x0001	1	0x00 0x01	Set the data mode of the upper and lower limits of the bin sorting parameter to the absolute value mode. Set the data mode of the upper and lower limits of the bin sorting parameter to the percentage mode.
R/W	0x0046	0x0004	1	float	Nominal value setting in bin sorting parameter percentage mode
R/W	0x0047 0x0048 0x0049 0x004A 0x004B 0x004C 0x004D 0x004E 0x004F 0x0050 0x0051 0x0052	0x0008 0x0008	2 2	f(low)+f(high) f(low)+f(high)	Lower and upper limits of BIN 1 Lower and upper limits of BIN 2 Lower and upper limits of BIN 3 Lower and upper limits of BIN 4 Lower and upper limits of BIN 5 Lower and upper limits of BIN 6 Lower and upper limits of BIN 1 (percentage) Lower and upper limits of BIN 2 (percentage) Lower and upper limits of BIN 3 (percentage) Lower and upper limits of BIN 4 (percentage) Lower and upper limits of BIN 5 (percentage) Lower and upper limits of BIN 6 (percentage)
R/W	0x0060	0x0001	1	0x01 0x00	Set the harmonic function switch to ON Set the harmonic function switch to OFF
R/W	0x0061	0x0001	1	0x00 0x01 0x02	Set the harmonic analysis item to voltage Set the harmonic analysis item to current Set the harmonic analysis item to voltage & current
R/W	0x0062	0x0001	1	0x00 0x01	Set the harmonic calculation standard to IEC Set the harmonic calculation standard to CSA
R/W	0x0063	0x0001	1	0x00 0x01 0x02	Set the harmonic display format to normal Set the harmonic display format to List Set the harmonic display format to BAR
R/W	0x0064	0x0001	1	0x00 0x01	Set the harmonic data format to absolute value Set the harmonic data format to percentage
W	0x0065	0x0001	1	0x00 0x01	Switch between list page up/times increase Switch between list page down/times decrease
R/W	0x0070	0x0001	1	0x00 0x01 0x02	Waveform only displays voltage Waveform only displays current Waveform displays both voltage and current
R/W	0x0080	0x0001	1	0x01 0x00	Set the key sound to ON Set the key sound to OFF

R/W	0x0081	0x0001	1	0x00 0x01	Set the language to English Set the language to Chinese
R/W	0x0082	0x0003	3	3char	Set the date, year, month and day: (11~99)+(1~12)+(1~31)
R/W	0x0083	0x0003	3	3char	Set the time, hour, minute and second: (0~23)+(0~59)+(0~59)
W	0x0090	0x0001	1	1~102	Load the internal file operations
W	0x0091	1+n	1+n	1+nBytes	Save the internal file operation, Fname length does not exceed 15 (the first data indicates the file number, the latter data indicates the file name to be saved)
R/W	0x0011	0x0001	1	0x00 0x02 0x03 0x01	Set to internal trigger Set to external trigger Set to bus trigger Set to manual trigger
R/W	0x0012	0x0004	1	float(4Byte)	Set the delay time 0`60.00
W	0x0013	0x0001	1	0x00	Bus trigger for once
R	0x00A0 0x00A1 0x00A2 0x00A3 0x00A4 0x00A5 0x00A6 0x00A7 0x00A8 0x00A9 0x00AA 0x00AB 0x00AC 0x00AD 0x00AE 0x00AF				Query test results - voltage (U) Query test results - voltage (I) Query test results - voltage (P) Query test results - voltage (PF) Query test results - voltage (FREQ) Query test results - voltage (VA) Query test results - voltage (VAR) Query test results - voltage (E) Query test results - voltage (CFu) Query test results - voltage (CFi) Query test results - voltage (Upk+) Query test results - voltage (Upk-) Query test results - voltage (Ipk+) Query test results - voltage (Ipk-) Query test results - voltage (Upp) Query test results - voltage (Ipp)
R	0x00B0				Return the result of the 2~50th harmonics of voltage in the current data mode
R	0x00B2				Return the result of the 2~10th harmonics of voltage in the current data mode
R	0x00B1				Return the result of the 2~50th harmonics of current in the current data mode
R	0x00B3				Return the result of the 2~10th harmonics of current in the current data mode

Chapter 10 Handler Interface

10.1 Port definitions

TH3311 series power meter provides the user with a 25-pin D_type terminal for each external trigger signal and external Pass/Fail interface on the rear panel. This interface is mainly used for the output of comparison result or sorting result. The pin definitions are shown in Table 10-1 below:

Pin	Definition	Pin	Definition	Pin	Definition	Pin	Definition	Pin	Definition
1	M4_Pass+	6	M2_Pass+	11	reserve	16	M4_Fail +	21	M2_Fail +
2	M3_Pass-	7	M1_Pass-	12	/EXT.TRIG	17	M3_Fail -	22	M1_Fail -
3	M3_Pass+	8	M1_Pass+	13	+5V	18	M3_Fail +	23	M1_Fail+
4	GND	9	GND	14	EXTV	19	+5V	24	GND
5	M2_Pass-	10	NC	15	M4_Fail -	20	M2_Fail -	25	M4_Pass-

(Table 10-1 Handle pin definition)

10.2 Specific description of the port

- ◆ +5V: internal power supply, +5V;
- ◆ GND: internal power supply, ground;
- ◆ EXTV: external power supply, if you do not use the internal power supply of the instrument and use external power supply, you need to remove the boot case, change one jump cap on the Handle board to the other side, the voltage input range is +5V~+30V;
- ◆ Note: It can be seen that the external power supply is not equipped with external GND. When the external power supply is selected, the high-end external power supply and /EXT.TRIG form a loop, providing a trigger signal to the instrument;
- ◆ /EXT.TRIG: External trigger pin, edge triggered, the default case is that high level, falling edge is valid. To use this function, change the trigger mode to “EXT” or “BUS” mode in the measurement setup;
- ◆ Pass+ and Pass-: controlled by Handle1~4, which are the two endpoints of Relay single gate output. When performing GD in GD/NG, if the test result is Pass, the output of Relay will be shorted, that is, Pass+ and Pass- are connected, the factory specification of the relay is: 30VDC/2A MAX;
- ◆ Fail+ and Fail-: When performing NG in GD/NG, if the test result is Fail, the output of Relay will be shorted, that is, Fail+ and Fail- are connected, although they are connected to the corresponding Pass+ and Pass- respectively on the hardware, but here to avoid misjudgment, it is recommended that if the user needs to control the external output when the comparison

Handle1~4 function	Function Introduction
-----------------------	-----------------------

or bin sorting result is Pass, the external circuit is connected at both ends of Pass+ and Pass-, and if the user needs to control the external output when the comparison or bin sorting result is Fail, the external circuit is connected at both ends of Fail+ and Fail-;

◆ Reserve: the system reserved pin;

10.3 HANDLER Timing Diagram

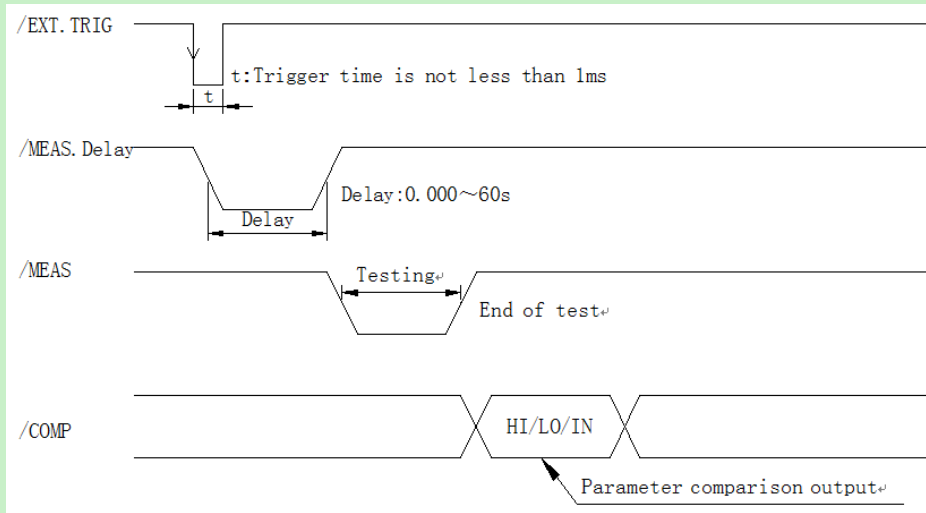

Figure 10-1 Handle timing diagram

Handle timing instructions:

- ◆ The external trigger pin only accepts falling edge triggers.
- ◆ The delay time after triggering is the user-settable delay time interval, which can be set from 0.000s to 60s.
- ◆ Start a test after the trigger delay ends, and get the relevant data of one test.
- ◆ The comparison output has 4 channels that can be used. The 4 channels have independent output control conditions that can be set. See the Handle setup page for details.

10.4 Introduction to HANDLE SETUP

Setup steps:

1) Enter into the <HANDLE SETUP> page and press the arrow keys to move the cursor. When the cursor is in the corresponding Function area after “Sign/EXT.TRIG”, there is no function display in the soft key area, indicating that the function cannot be changed, only for display;

2) When the cursor is located in the corresponding Function area after “Signal Hand1~4”, the following soft keys are displayed in the soft key area of the screen:

Unqualified conduction, Qualified conduction, Unqualified pulse, Qualified pulse and OFF, there are 5 function options.

The different functions are as follows:

FAIL CONTACT	When the corresponding parameter comparison is unqualified, the relay is closed and the output is conductive.
PASS CONTACT	When the corresponding parameter comparison is qualified, the relay is closed and the output is conductive.
FAIL PULSE	When the corresponding parameter comparison is unqualified, the relay is pulled for 5ms, and the output is conductive for 5ms.
PASS PULSE	When the corresponding parameter comparison is qualified, the relay is pulled for 5ms, and the output is conductive for 5ms.
OFF	The corresponding channel relay does not pull in and the export is in the off state.

3) Press the corresponding soft key or press the ENTER key to complete the setting.