

INSULATION RESISTANCE METER
USERS MANUAL
HT3530

March 2021
Rev1.3

| | |
|---|-----------|
| INTRODUCTION | 5 |
| CHECKING PACKAGE CONTENTS..... | 5 |
| SECURITY INFORMATION | 7 |
| USAGE NOTES | 9 |
| CHAPTER I OVERVIEW..... | 12 |
| 1.1 INTRODUCTION | 12 |
| 1.2 PERFORMANCE CHARACTERISTICS | 12 |
| 1.3 NAMES OF SECTIONS AND SUMMARY OF OPERATIONS | 13 |
| 1.4 DIMENSIONS | 15 |
| 1.5 PAGE COMPOSITION..... | 16 |
| CHAPTER II PREPARATION BEFORE TESTING | 19 |
| 2.1 TEST FLOW PREVIEW | 19 |
| 2.2 BASIC PARAMETER SETTING PROCESS | 21 |
| 2.3 INSPECTION BEFORE MEASUREMENT..... | 22 |
| 2.4 METHOD FOR CONNECTING TEST LINES | 23 |
| 2.5 METHOD FOR CONNECTING ELECTRODE BOXES | 25 |
| CHAPTER III BASIC SETTINGS..... | 26 |
| 3.1 SET TEST VOLTAGE..... | 26 |
| 3.2 SET TEST RANGE | 26 |
| 3.3 SET TEST SPEED | 27 |
| 3.4 COMPARATOR FUNCTION..... | 27 |
| 3.5 RESPONSE MODE OF SORTING RESULTS..... | 28 |
| 3.6 SURFACE RESISTIVITY | 29 |
| 3.8 LEAKAGE CURRENT MEASUREMENT | 34 |
| CHAPTER IV MEASUREMENT | 35 |
| 4.1 START-UP TEST | 35 |
| 4.2 TEST RANGE | 35 |

| | |
|---|-----------|
| 4.3 SETTING TEST PARAMETERS..... | 36 |
| 4.4 CLEAR CIRCUIT | 37 |
| CHAPTER V MEASUREMENT SETTINGS SAVE..... | 38 |
| 5.1 SAVE MEASUREMENT SETTINGS | 39 |
| 5.2 CALL MEASUREMENT SETTINGS..... | 39 |
| 5.3 DELETE MEASUREMENT SETTINGS | 40 |
| 5.4 RENAME MEASUREMENT SETTINGS | 41 |
| CHAPTER VI EXT I/O INTERFACE (HANDLER) | 42 |
| 6.1 EXT I/O PORTS AND SIGNALS..... | 43 |
| 6.1.1 Port signal details | 43 |
| 6.1.2 Port Signal Connection Mode | 45 |
| 6.2 SEQUENCE DIAGRAM..... | 46 |
| 6.2.1 Sequence diagram of external trigger | 46 |
| 6.2.2 Read flow when triggered externally..... | 47 |
| CHAPTER VII COMMUNICATIONS..... | 48 |
| 7.1 RS232 COMMUNICATION MODE | 48 |
| 7.1.1 Interface and Cable | 48 |
| 7.1.2 RS232 Connection Mode..... | 49 |
| 7.1.3 RS232 Communications Settings..... | 49 |
| 7.2 LAN COMMUNICATION MODE | 50 |
| 7.2.1 Interface and Cable | 50 |
| 7.2.2 LAN Connection Mode | 50 |
| 7.2.3 LAN Communications Settings | 51 |
| 7.3 USB INTERFACE | 51 |
| CHAPTER VIII PARAMETERS | 52 |
| 8.1 GENERAL PARAMETERS | 52 |
| 8.2 ACCURACY | 53 |

Introduction

Thank you for purchasing HT3530 Insulation Resistance Meter. To obtain maximum performance from the product, please read this manual first, and keep it handy for future reference.

Registered trademarks

Windows and Excel are registered trademarks of Microsoft Corporation in the United States or other countries.

Checking Package Contents

When receiving the instrument, please check carefully to ensure that the instrument is not damaged during transit. In addition, special inspections of accessories, panel switches and connectors are required. If the instrument is found to be damaged or it fails to operate as described in the user manual, please contact us.

To transport this instrument, use the original packaging and wrap it in a double carton. Damage during transit is not covered by the warranty.

Check the package contents as follows:

| | Name | Quantity |
|---|------------------------------------|----------|
| 1 | HT3530 Insulation Resistance Meter | 1 |
| 2 | Test Leads | 1 |
| 3 | RS232 Communication Cable | 1 |
| 4 | AC Power Cord | 1 |

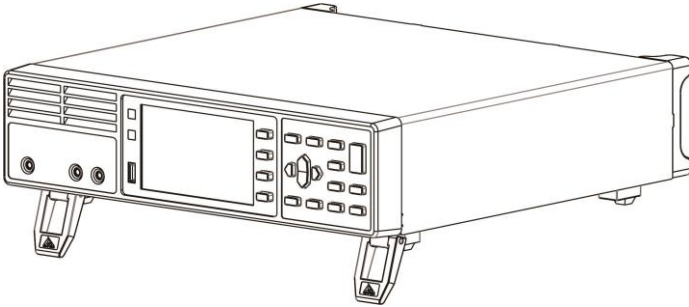

HT3530 Insulation Resistance Meter

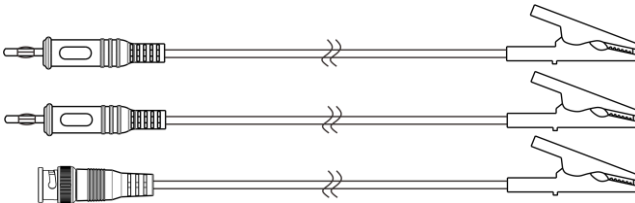

Test Leads

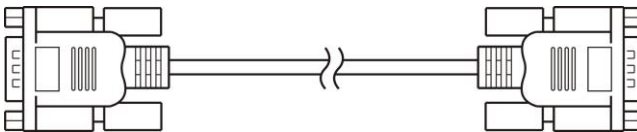





RS232 Communication Cable

Security information





The instrument is designed to comply with the IEC 61010 safety standard and has been thoroughly tested for safety prior to shipment. However, if it is used improperly, it may cause injury or death and damage the instrument. Be sure to read through this manual and its precautions before use. Our company does not assume any responsibility for accidents and injuries not caused by defects in the instrument itself.

Safety signs

This manual marks the relevant signs for safe operation of the instrument. In order to ensure the safety of the instrument and its users, please read the following safety signs and operating precautions carefully before use.

| | |
|---|---|
|  | Indicates very important message in this manual. When the symbol is printed on the instrument, refer to a corresponding topic in the Instruction Manual. |
|  | Indicates DC (direct current) |
|  | Indicates a fuse |
|  | Indicates earth terminal |

In this manual, the risk seriousness and the hazard levels are classified as follows:

| | |
|--|---|
|  DANGER | Indicates an imminently hazardous situation that will result in death or serious injury to the operator. |
|  WARNING | Indicates a potentially hazardous situation that will result in death or serious injury to the operator. |
|  CAUTION | Indicates a potentially hazardous situation that may result in minor or moderate injury to the operator or damage to the instrument or malfunction. |
|  NOTE | Indicates functions of the instrument or relative suggestion of a correct operation. |

Accuracy

We define measurement tolerances in terms of f.s. (full scale), rdg. (reading) and dgt. (digit) values, with the following meanings:

f.s. (Maximum display value)

This is usually the maximum display value. In the instrument, this indicates the currently used range.

rdg. (Reading or displayed value)

The value currently being measured and indicated on the measuring instrument.

dgt. (Resolution)

The smallest displayable unit on a digital measuring instrument, i.e., the input value that causes the digital display to show a “1”.

Usage Notes

Installation environment

Operating temperature and humidity ranges:

0°C to 40°C, 80%RH or less (no condensation)

Temperature and humidity range to ensure accuracy:

23 ± 5°C, 80%RH or less (no condensation)

To avoid failure or damage to the instrument, do not place the tester in the following places:



- Places where the sun is shining directly at high temperatures
- Places exposed to large amounts of dust particles
- Places exposed to water, oil, chemicals, or solvents
- Places where corrosive or explosive gases are flooded
- Places with strong electromagnetic fields or electromagnetic radiation
- Places where mechanical vibration is frequent

Checking before use

Before the first use of the instrument, verify that the operation is normal to ensure that there is no damage occurred during storage or shipping. If you find any damage, please contact us.

| | |
|---|--|
|  | <p>Before using the instrument, check that the coating of the test lead or cable is not torn and does not expose metal parts. If the test wire is not insulated and the conductor is exposed, there may be a risk of electric shock using this instrument, please contact us in this case.</p> |
|---|--|

Use of instruments

| | |
|--|---|
|  DANGER | To avoid electric shock, do not disassemble the instrument electronic enclosure. There are high pressure and high temperature parts inside the instrument during operation. |
|  CAUTION | Do not place the instrument on an unstable or slanted surface. It may drop or fall, causing injury or instrument failure. |
|  NOTE | To avoid corrosion or damage to the instrument due to battery leakage, remove the batteries from the instrument if it is to be kept in storage for an extended period. Be sure to turn the power off after using it. |

Measurement considerations

| | |
|---|--|
|  DANGER | To avoid electric shocks and short circuits, the following procedures must be followed: Please do not wet this instrument or measure with wet hands. Otherwise, it will lead to electric shock accident. Do not modify, disassemble or repair. Otherwise, it will cause fire, electric shock accident or personnel injury. |
|---|--|



CAUTION

In order to prevent damage to this instrument, please avoid vibration and collision during handling and use. Pay special attention to the collision caused by falling.

Do not connect measuring terminals to EX.I/O terminals and communication terminals to avoid damage to this instrument.

Use of test leads and cables



CAUTION

For safety reasons, the original test line or test line selection should be used when testing.

To avoid damaging the cables, do not bend or pull the base of cables and the leads.

The front end probe of the test leads are sharp and careful not to be scratched.

To avoid damage to the test leads, when plug/pull the test line, don't hold the cable but connector.

Chapter I Overview

1.1 Introduction

HT3530 is an insulation resistance tester controlled by high performance microprocessor. Seven range test, output voltage continuously adjustable, can test $500\Omega\sim 9.9\text{P}\Omega$ resistance, maximum display 99999, test speed up to 5 times per second.

Instrument has professional sorting function, with 10 sets of storage data, a variety of sorting sound settings, equipped with Handler interface, used in automatic sorting system to complete automatic pipeline testing. Built-in RS232 interface and LAN interface for remote control and data acquisition and analysis.

Computer remote control instruction compatible with SCPI (Standard Command for Programmable Instrument), efficient completion of remote control and data acquisition functions.

The instrument can measure the insulation resistance and leakage current of various electronic components, equipment, dielectric materials, wire and cable, etc. The surface resistance and volume resistivity of the supporting electrode box can be tested.

1.2 Performance characteristics

Appearance

- ◇ Display with 4.3 inch high resolution TFT screen display, simple operation
- ◇ Small fuselage, powerful

Excellent test performance

- ◇ Rereading voltage 0.5% accuracy
- ◇ Maximum insulation resistance 1% accuracy

Rapid testing

- ◇ A minimum test cycle of ms 200

Constant voltage test

- ◇ Fast measurement of insulation resistance by constant

voltage test

Rich interface configuration

- ◇ HANDLER interface
- ◇ RS-232 interface
- ◇ Ethernet interface (optional)
- ◇ U disk interface

Power supply

- ◇ 198~240 V Power supply
- ◇ Power supply 47 Hz~63 Hz
- ◇ 50 W maximum power consumption

1.3 Names of sections and summary of operations

Front view

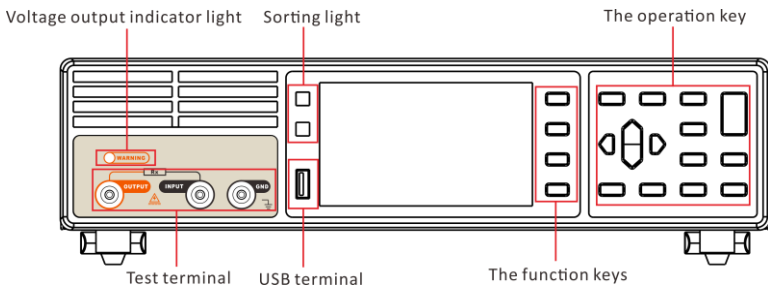



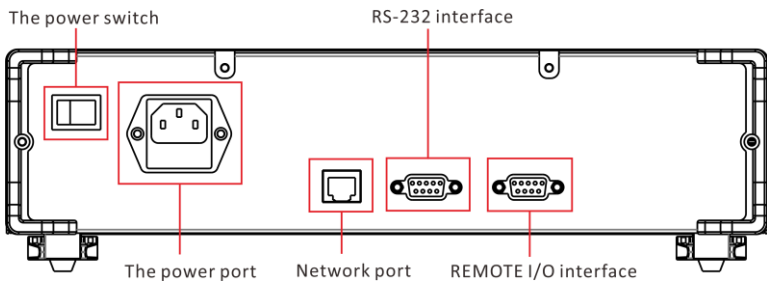



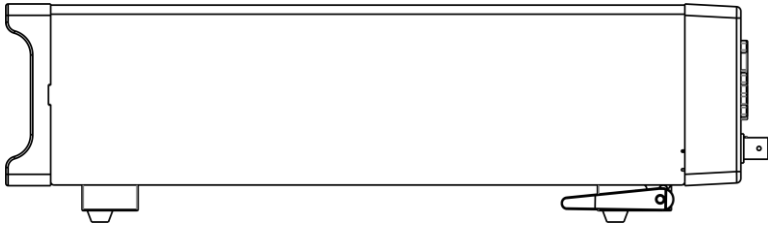







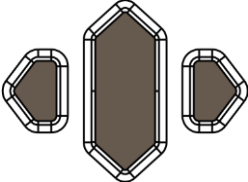

Back view



Side view



| Press button | Note |
|---|---|
|  | Function key [F1] |
|  | Function key [F2] |
|  | Function key [F3] |
|  | Function key [F4] |
|  | Function exit key [ESC] |
|  | Function determination key [ENTER] |
|  | Direction key, used to select menu items or set values |
|  | Page key, Switch [Test page]-[Set page]- [Save page]-[Communications page]-[System page] |
|  | [0. ADJ] key to zero |

| | |
|---|---|
|  | Voltage Setup Key [V-SET] |
|  | Test mode resistance/current switching key [R/I] |
|  | Trigger key [ON/OFF], start and terminate tests |
|  | Speed key [RATE], set the measurement rate |
|  | Key lock key, long press [LOCK] key, lock page other key failure, long press can release lock |
|  | Upper limit setting key [UP-LIM] for setting upper limit values |
|  | Lower limit setting key [LO-LIM] for setting lower limit values |

1.4 Dimensions

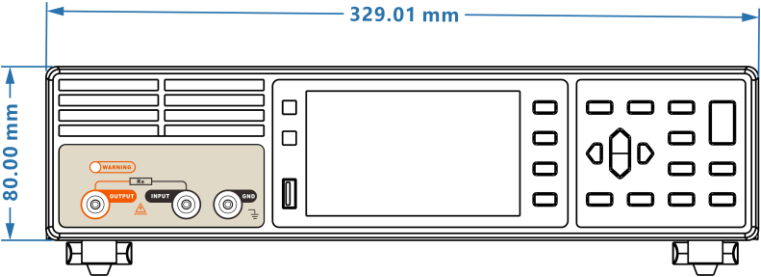

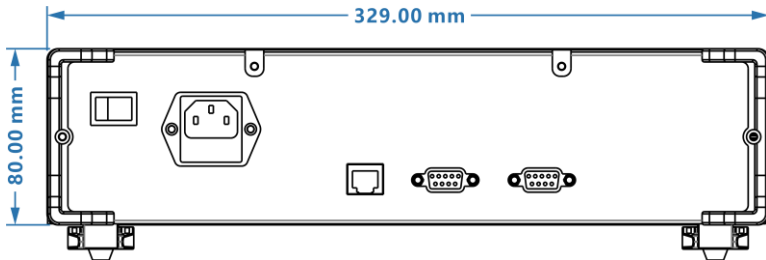

1.5 Page composition

R Measurement Page

| MEAS | SET | SAVE | COM | SYS | | |
|--|--------|--------|---------|-----------|-----------|--------|
| VOLT | 1000 V | RANG | 1 | RANG AUTO | OFF | RANG + |
| RATE | FAST | UP-LIM | 1000 TΩ | LO-LIM | 1.000 kΩ | RANG - |
| <div style="background-color: black; color: white; padding: 10px;"> <p style="font-size: 2em; margin: 0;">R: 0.0000MΩ</p> <p style="margin: 0;">V: -0.000v T: 0.0s</p> </div> | | | | | RANG AUTO | |
| SCOPE: 500.0k-50.0M | | | | | | RESET |

I Measurement Page

| MEAS | SET | SAVE | COM | SYS | | |
|--|--------|--------|---------|-----------|-----------|--------|
| VOLT | 1000 V | RANG | 7 | RANG AUTO | OFF | RANG + |
| RATE | FAST | UP-LIM | 1000 TΩ | LO-LIM | 1.000 kΩ | RANG - |
| <div style="background-color: black; color: white; padding: 10px;"> <p style="font-size: 2em; margin: 0;">I: 0.00pA</p> <p style="margin: 0;">V: -0.000v T: 0.0s</p> </div> | | | | | RANG AUTO | |
| SCOPE: 2nA-0.01pA | | | | | | RESET |

Setting page

| MEAS | SET | SAVE | COM | SYS | |
|-----------|-------------------------------------|------|-----|-----|-----|
| MEAS TIME | <input type="button" value="OFF"/> | | | | OFF |
| CHG TIME | <input type="button" value="OFF"/> | | | | ON |
| DISC TIME | <input type="button" value="OFF"/> | | | | |
| RS | <input type="button" value="OFF"/> | | | | |
| RV | <input type="button" value="OFF"/> | | | | |
| DIGIT | <input type="button" value="5"/> | | | | |
| BEEP MODE | <input type="button" value="PASS"/> | | | | |
| MEAS MODE | <input type="button" value="CONT"/> | | | | |

Save page

| MEAS | SET | SAVE | COM | SYS | | | | | | | | | | | | | | | | | | | | | | | | | | | | | | | | | | | | | | | | | | | | | |
|---|----------|------------|-------|-----|--------|------|--|--|----|----------|------|------|----|-------|------|---|----|-------|-----------|-----|----|-------|------------|-----|----|-------|--------|-------|----|-------|--------|-------|----|-------|-----------|------|----|-------|--|--|----|-------|--|--|----|-------|--|--|------|
| <table border="1"> <thead> <tr> <th>No.</th> <th>Name</th> <th></th> <th></th> </tr> </thead> <tbody> <tr> <td>01</td> <td>PANEL_01</td> <td>VOLT</td> <td>0050</td> </tr> <tr> <td>02</td> <td>-----</td> <td>RANG</td> <td>6</td> </tr> <tr> <td>03</td> <td>-----</td> <td>MEAS TIME</td> <td>OFF</td> </tr> <tr> <td>04</td> <td>-----</td> <td>CHARG TIME</td> <td>OFF</td> </tr> <tr> <td>05</td> <td>-----</td> <td>UP-LIM</td> <td>----Ω</td> </tr> <tr> <td>06</td> <td>-----</td> <td>LO-LIM</td> <td>----Ω</td> </tr> <tr> <td>07</td> <td>-----</td> <td>BEEP MODE</td> <td>PASS</td> </tr> <tr> <td>08</td> <td>-----</td> <td></td> <td></td> </tr> <tr> <td>09</td> <td>-----</td> <td></td> <td></td> </tr> <tr> <td>10</td> <td>-----</td> <td></td> <td></td> </tr> </tbody> </table> | | | | | No. | Name | | | 01 | PANEL_01 | VOLT | 0050 | 02 | ----- | RANG | 6 | 03 | ----- | MEAS TIME | OFF | 04 | ----- | CHARG TIME | OFF | 05 | ----- | UP-LIM | ----Ω | 06 | ----- | LO-LIM | ----Ω | 07 | ----- | BEEP MODE | PASS | 08 | ----- | | | 09 | ----- | | | 10 | ----- | | | SAVE |
| No. | Name | | | | | | | | | | | | | | | | | | | | | | | | | | | | | | | | | | | | | | | | | | | | | | | | |
| 01 | PANEL_01 | VOLT | 0050 | | | | | | | | | | | | | | | | | | | | | | | | | | | | | | | | | | | | | | | | | | | | | | |
| 02 | ----- | RANG | 6 | | | | | | | | | | | | | | | | | | | | | | | | | | | | | | | | | | | | | | | | | | | | | | |
| 03 | ----- | MEAS TIME | OFF | | | | | | | | | | | | | | | | | | | | | | | | | | | | | | | | | | | | | | | | | | | | | | |
| 04 | ----- | CHARG TIME | OFF | | | | | | | | | | | | | | | | | | | | | | | | | | | | | | | | | | | | | | | | | | | | | | |
| 05 | ----- | UP-LIM | ----Ω | | | | | | | | | | | | | | | | | | | | | | | | | | | | | | | | | | | | | | | | | | | | | | |
| 06 | ----- | LO-LIM | ----Ω | | | | | | | | | | | | | | | | | | | | | | | | | | | | | | | | | | | | | | | | | | | | | | |
| 07 | ----- | BEEP MODE | PASS | | | | | | | | | | | | | | | | | | | | | | | | | | | | | | | | | | | | | | | | | | | | | | |
| 08 | ----- | | | | | | | | | | | | | | | | | | | | | | | | | | | | | | | | | | | | | | | | | | | | | | | | |
| 09 | ----- | | | | | | | | | | | | | | | | | | | | | | | | | | | | | | | | | | | | | | | | | | | | | | | | |
| 10 | ----- | | | | | | | | | | | | | | | | | | | | | | | | | | | | | | | | | | | | | | | | | | | | | | | | |
| | | | | | LOAD | | | | | | | | | | | | | | | | | | | | | | | | | | | | | | | | | | | | | | | | | | | | |
| | | | | | CLEAR | | | | | | | | | | | | | | | | | | | | | | | | | | | | | | | | | | | | | | | | | | | | |
| | | | | | RENAME | | | | | | | | | | | | | | | | | | | | | | | | | | | | | | | | | | | | | | | | | | | | |

Newsletter page

| MEAS | SET | SAVE | COM | SYS | |
|--|-----|------|-----|-----|-------|
| COM MODE RS232 | | | | | RS232 |
| RADIO <input type="text" value="OFF"/> | | | | | TCP |
| BAUDRATE <input type="text" value="9600"/> | | | | | |

System page

| MEAS | SET | SAVE | COM | SYS | |
|----------------|-----|------|-----|-----|----|
| LANG EN | | | | | CN |
| VERSION V1.0.0 | | | | | EN |

Chapter II Preparation before testing

2.1 Test flow preview

The instrument remains in the power off state, follow the following steps to prepare before testing.

1. turn off instrument power, connect test line

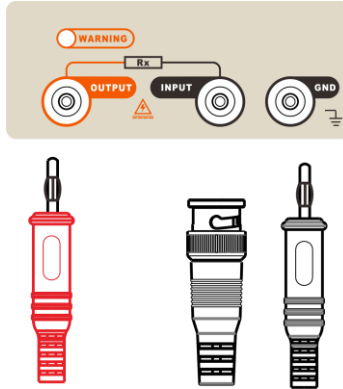

2. insert power cord

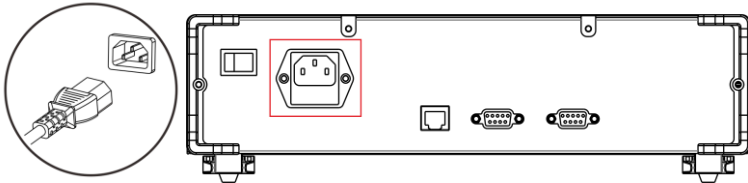

Ensure that the power line grounding is good, conducive to the stability of the test.

3. turn the power at the end of the instrument on

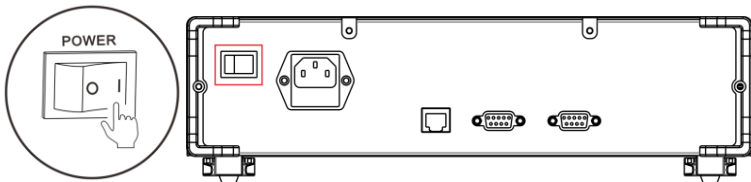

4. setting test parameters (see later sections for details)
5. testing

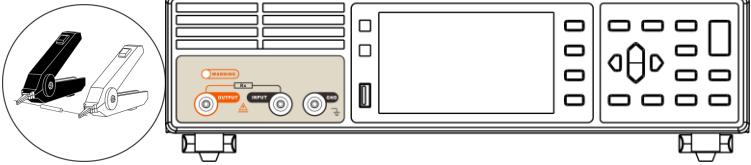

6. test is over, power off

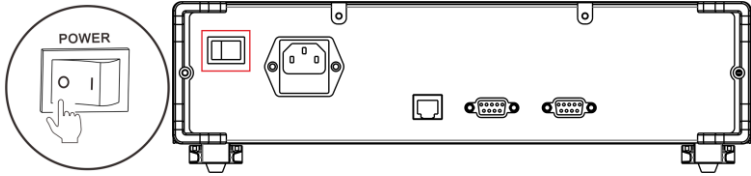

2.2 Basic parameter setting process

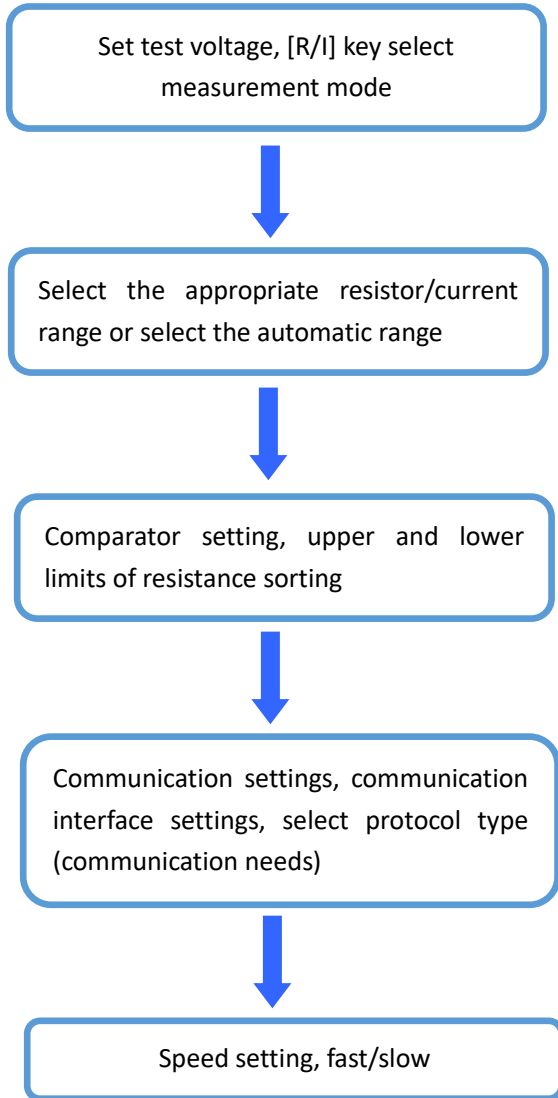

2.3 Inspection before measurement

Before use, please confirm that there is no failure caused by preservation and transportation, and then use after checking and confirming the operation. If you confirm that there is a fault, please contact our sales network.

Confirmation of this instrument and peripheral equipment

| Inspection projects | Processing methods |
|---|--|
| Is this instrument damaged or cracked? Is the internal circuit exposed? | Do not use when there is damage, please send repair. |
| Is metal sheet attached to the terminal and other garbage? | When attached, please wipe it with cotton swabs. |
| Is the outer skin of the test line damaged or metal exposed? | In case of damage, the measurement value may be unstable or error. It is recommended to replace the wire without damage. |

Confirmation of power on

| Inspection projects | Processing methods |
|---|--|
| When the power is turned on, is the screen all lit, and is the measurement screen normal? | Different display, may be the internal failure of this instrument, please send repair. |

2.4 Method for connecting test lines



The test line port is sharp, be careful not to be scratched.
For safety, the test line attached to the instrument should be used.

To avoid electric shock, ensure that the test line is properly connected

Front panel connection

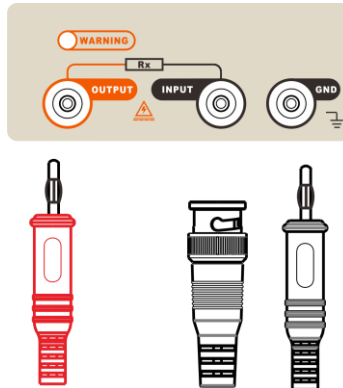

Test Line Connection

1. connecting the tested parts with polarity, such as capacitors and other polar parts, the positive and negative electrodes must be distinguished and tested according to the following wiring methods:

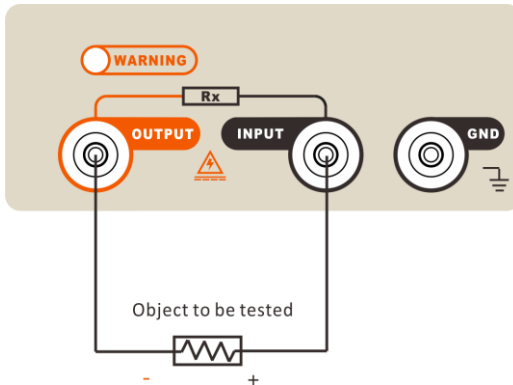

Output end outputs negative voltage and connects the negative end of the measured part. Input end is connected to the positive end of the measured piece.

| | |
|--|---|
| | <p>Polar devices (electrolytic capacitors, etc.) should be connected according to positive and negative electrodes, otherwise it will pose a threat to personal safety.</p> |
|--|---|

2. Connect non-polar parts, such as wire and cable, rubber materials and other non-polar parts, no special requirements, according to the following wiring test;

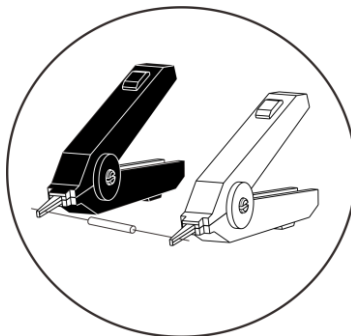

3. High resistance measurement, need to grounding the GND, shielding external interference.

2.5 Method for connecting electrode boxes

HT3530 matching electrode box can test the surface resistance and volume resistivity of the material, 0305 electrode box is option, the customer customized according to the need.

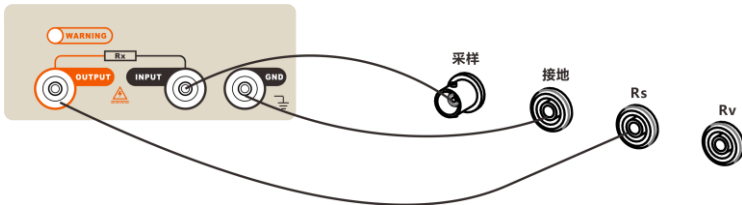
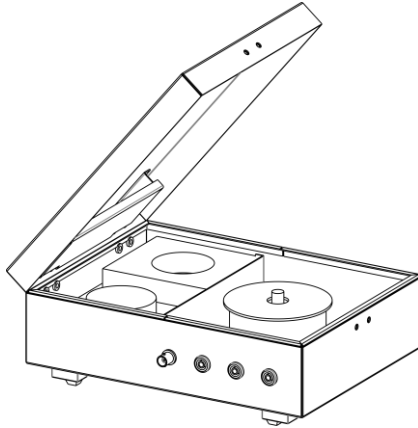

Test surface resistivity such as the above connection, the OUTPUT end of the test instrument connected to the Rs end of the electrode box;

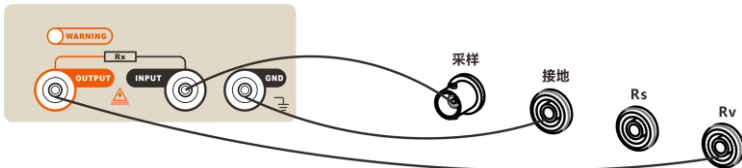

Input instrument current sampling terminal is connected to the electrode box Sample current sampling terminal for sampling current.

The earthing end GND the instrument is connected to the earthing

end GND the electrode box for shielding.

Output instrument voltage output is connected to the electrode box Rs or Rv high voltage terminal to add voltage to the measured object.

Chapter III Basic settings

3.1 Set test voltage

HT3530 voltage setting range from -1000 V~-1 V. Press the [V-SET] key on the instrument at the test interface, then set the voltage value with the directional key, press [ENTER] to confirm ,[ESC] cancel;

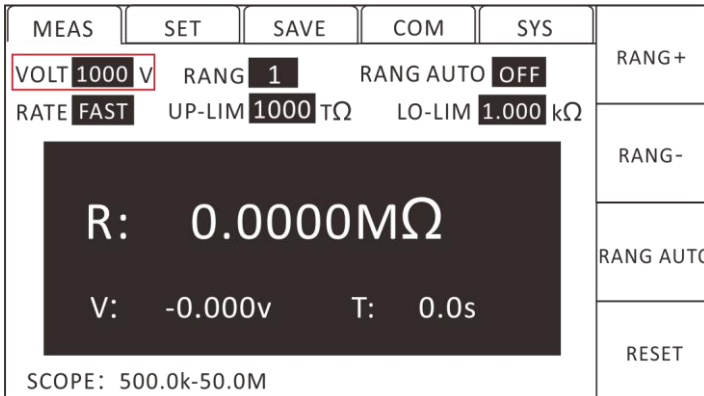

3.2 Set Test Range

At the test interface, press [F3] to select the range automatic option to turn on or off the automatic range function. Switch to range automatic state, display indicator "range automatic: ON", you can also press [F1] [F2] to manually select the test range.

HT3530 there are 7 test ranges, can change the test range under automatic range and manual range, change the range number under automatic range, automatic range will be closed.

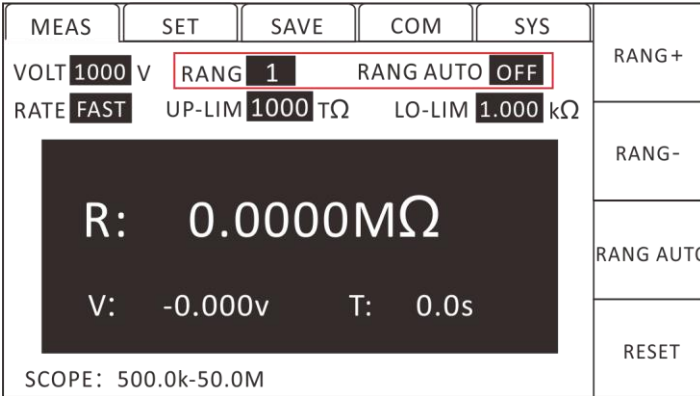

3.3 Set Test Speed

The completion of primary sampling is from test generation-A / D conversion-operation to display measurement results and sorting results. This period of time is called sampling time. Sampling rate refers to the number of samples per second. HT3530 provide two rate settings for the user to choose from, fast (5 beats/s) and slow (1 beats/s), directly press the [RATE] key on the instrument panel to switch the test speed.

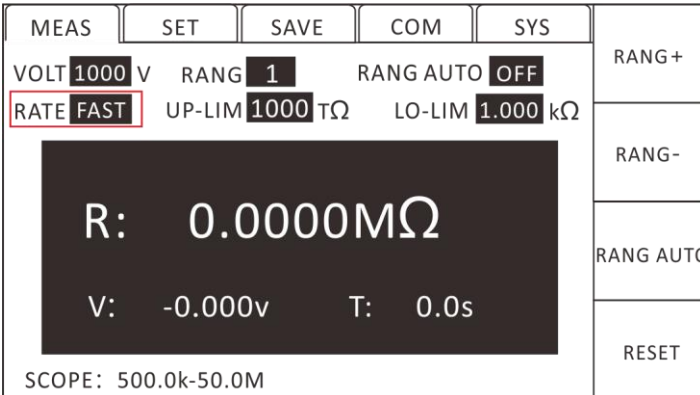

3.4 Comparator function

Press [UP-LIM] to select the upper limit of comparison, press [F1] to turn on / off the upper limit comparison function, after opening the use of directional keys to set the upper limit value, using [F2]、

[F3] numerical unit rate;

| MEAS | SET | SAVE | COM | SYS | | |
|---|--------|--------|---------|-----------|----------|-----------|
| VOLT | 1000 V | RANG | 1 | RANG AUTO | OFF | RANG+ |
| RATE | FAST | UP-LIM | 1000 TΩ | LO-LIM | 1.000 kΩ | RANG- |
| <div style="background-color: black; color: white; padding: 10px; border: 1px solid black;"> <p style="font-size: 2em; margin: 0;">R: 0.0000MΩ</p> <p style="margin: 0;">V: -0.000v T: 0.0s</p> </div> | | | | | | RANG AUTO |
| SCOPE: 500.0k-50.0M | | | | | | RESET |

Press [LO-LIM] to select the lower limit of comparison, press [F1] to open / close the upper limit comparison function, after opening, use the directional key to set the lower limit value, use [F2]、[F3] switch numerical unit rate;

After closing the upper and lower limits of the comparator, the instrument sorting system will no longer work, and the signal about the comparator output in the Handler interface will also be turned off.

3.5 Response mode of sorting results

Click [PAGE]] on the test page to switch to the settings page, using the upper and lower left and right keys to select the sound mode;

| MEAS | SET | SAVE | COM | SYS | |
|-----------|------|------|-----|-----|------|
| MEAS TIME | OFF | | | | OFF |
| CHG TIME | OFF | | | | PASS |
| DISC TIME | OFF | | | | FAIL |
| RS | OFF | | | | |
| RV | OFF | | | | |
| DIGIT | 5 | | | | |
| BEEP MODE | PASS | | | | |
| MEAS MODE | CONT | | | | |

HT3530 have three modes of sound: OFF、PASS、FAIL. Press [F1]、
 [F2]、 [F3] to select the sound mode and press [ESC] to exit the
 settings page.

OFF: turn off the sound;

PASS: sorting qualified, make sound;

FAIL: sorting is not qualified, make a sound.

3.6 Surface resistivity

Click [PAGE] on the test page to switch to the settings page, using
 the directional key to select the surface resistance;

| MEAS | SET | SAVE | COM | SYS | | | | |
|-----------|--|------|------------------------------------|-----|-----|------------------------------------|----|--------|
| MEAS TIME | <input type="text" value="OFF"/> | | | | OFF | | | |
| CHG TIME | <input type="text" value="OFF"/> | | | | ON | | | |
| DISC TIME | <input type="text" value="OFF"/> | | | | | | | |
| RS | <input checked="" type="text" value="ON"/> | LENG | <input type="text" value="34.56"/> | cm | GAP | <input type="text" value="01.00"/> | cm | PRESET |
| RV | <input type="text" value="OFF"/> | | | | | | | |
| DIGIT | <input type="text" value="5"/> | | | | | | | |
| BEEP MODE | <input type="text" value="PASS"/> | | | | | | | |
| MEAS MODE | <input type="text" value="CONT"/> | | | | | | | |

Press [F1] to close the surface resistance ,[F2] open the surface
 resistance ,[F3] preset perimeter and distance, you can also use
 the direction key to manually set the perimeter and distance of
 the object to be tested ;[ESC] exit, return to the surface resistivity
 Rs measurement page;

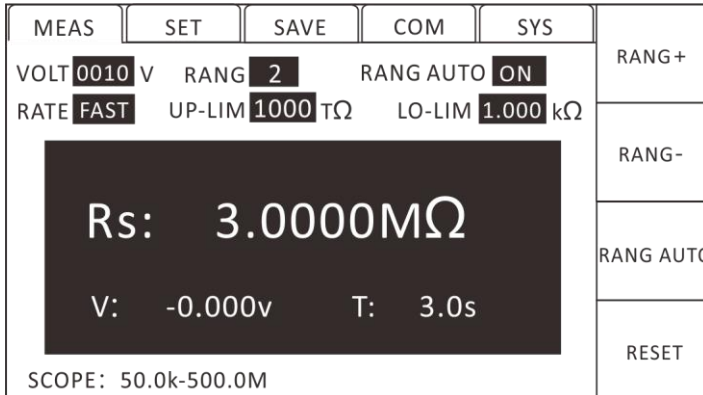

Surface resistivity

Surface resistivity is the resistance value per unit area. Surface resistance formula:

$$ps = Rs * (\text{Perimeter} / \text{Gap})$$

Among them:

ps indicate surface resistivity (Ω)

Perimeter indicate effective perimeter (cm)

Gap indicate distance between main and secondary electrodes (cm)

Rs indicate surface resistance measured

Perimeter formula:

$$\text{Perimeter} = \pi \times (D2 + D1) / 2$$

Gap formula:

$$\text{Gap} = (D2 - D1) / 2$$

Among them:

D1 indicate main electrode diameter (cm)

D2 indicate pair electrode diameter (cm)

Specification of parameters of insulated resistance electrode box

| Parameters | Note | Valid value |
|------------|-------------------------|-------------|
| D1 | Main electrode diameter | 5.0cm |

| | | |
|-----------|--|--|
| D2 | Secondary electrode diameter | 6.0cm |
| B | Effective area coefficient | $0 \leq B \leq 1$ Default 0 |
| AREA | Effective area | $0 \text{ cm}^2 \leq \text{AREA} \leq 9999.9 \text{ cm}^2$ Default $\text{cm}^2 19.635$ |
| Perimeter | Effective perimeter | $0 \text{ cm} \leq \text{Perimeter} \leq 999.99 \text{ cm}$ 17.278 cm default |
| Gap | Distance between main and secondary electrodes | $0.001 \text{ cm} \leq \text{Gap} \leq 99.99 \text{ cm}$ 0.5 cm by default |

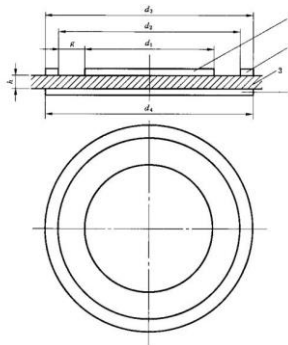

Basic line for measuring volume resistivity and surface resistivity by electrodes

Among them:

- 1- Protected electrodes;
- 2- Protective electrodes;
- 3- Sample;
- 4- Non-protection of electrodes;

- d1– diameter of the protected electrode;
- d2– protection electrode inner diameter
- d3– protection electrode outer diameter
- d4– Non-protected electrode diameter
- g – electrode gap
- h – specimen thickness

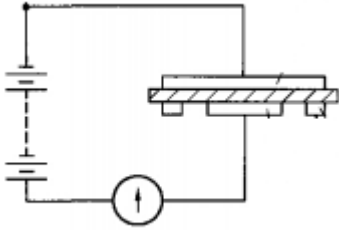

a) measurement of volume resistivity line

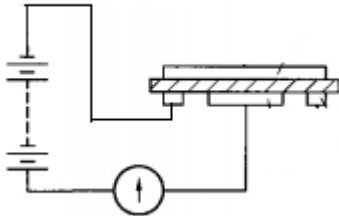

b) measurement of surface resistivity lines

3.7 Volume resistivity

Click [PAGE] on the test page to switch to the settings page, using the directional key to select the volume resistance;

| MEAS | SET | SAVE | COM | SYS | |
|-----------|--|---|--|-----|--------|
| MEAS TIME | <input type="button" value="OFF"/> | | | | OFF |
| CHG TIME | <input type="button" value="OFF"/> | | | | ON |
| DISC TIME | <input type="button" value="OFF"/> | | | | |
| RS | <input type="button" value="OFF"/> | | | | PRESET |
| RV | <input checked="" type="button" value="ON"/> | THICK <input type="text" value="00.30"/> cm | AREA <input type="text" value="19.635"/> cm ² | | |
| DIGIT | <input type="text" value="5"/> | | | | |
| BEEP MODE | <input type="button" value="PASS"/> | | | | |
| MEAS MODE | <input type="button" value="CONT"/> | | | | |

Press [F1] to close the volume resistance , [F2] open the volume resistance , [F3] preset thickness and area, you can also use the direction key to manually set the thickness and area of the object to be measured ; [ESC] exit, return to the volume resistivity Rv measurement page;

| MEAS | SET | SAVE | COM | SYS | |
|--|--|--|-----|-----|-----------|
| VOLT <input type="text" value="0010"/> V | RANG <input checked="" type="button" value="2"/> | RANG AUTO <input checked="" type="button" value="ON"/> | | | RANG+ |
| RATE <input checked="" type="button" value="FAST"/> | UP-LIM <input type="text" value="1000"/> TΩ | LO-LIM <input type="text" value="1.000"/> kΩ | | | RANG- |
| <div style="background-color: black; color: white; padding: 10px; border: 1px solid black;"> <p style="font-size: 2em; margin: 0;">Rv: 6.0000MΩ</p> <p style="margin: 0;">V: -0.000v T: 6.0s</p> </div> | | | | | RANG AUTO |
| SCOPE: 50.0k-500.0M | | | | | RESET |

Volume resistivity

Volume resistivity is the resistance value per unit volume. In general, the formula of volume resistivity is:

$$\rho_v = \text{Area}/t \times R_v$$

Among them:

ρ_v indicate volume resistivity (Ω-cm)

Area indicates effective area (cm²)

t indicates sample thickness (cm)

Rv indicate volume resistance measured (Ω)

The effective area can be set according to the following formula:

$$\text{Area} = \frac{\pi \times \left(D_1 + \frac{B(D_2 - D_1)}{2} \right)^2}{4}$$

Among them:

D1 indicate main electrode diameter (cm)

D2 indicate pair electrode diameter (cm)

B indicate effective area coefficient

3.8 Leakage Current Measurement

At the resistance measurement page, press [R/I] to switch resistance measurement and leakage current measurement.

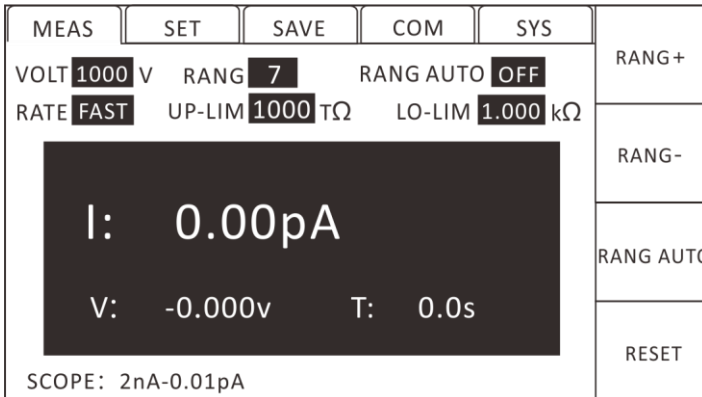

Chapter IV Measurement

4.1 Start-up test

1. set the relevant parameters (see Chapter 3 for details);

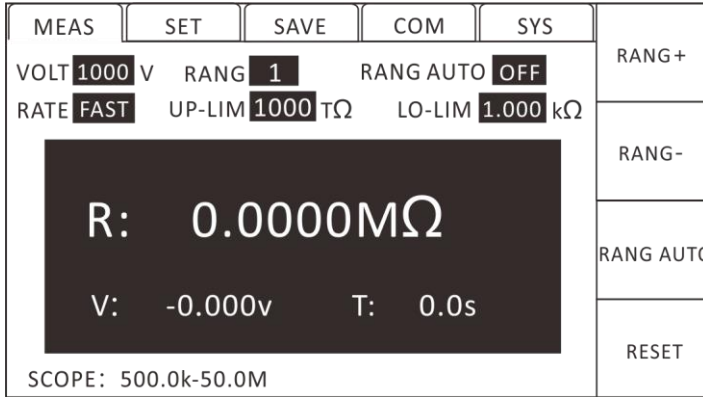

2. Connect the test line correctly (see Chapter 2 for details);

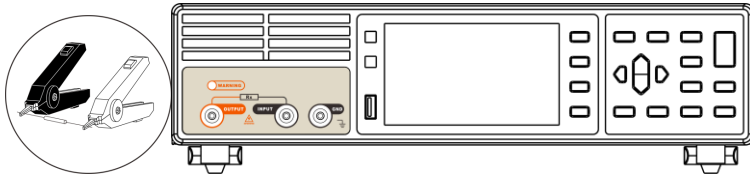

3. press  to start testing;

4.2 Test Range

A total of 7 test ranges, in the test interface, press [F3] to select the "range automatic" option, you can turn on the automatic range function. Switch to range automatic state, display indicator

"range automatic: ON" on the screen. The instrument will automatically select the most suitable range for measurement through the following table.

Range number, current range and range variation

| Range Number | Current range | Alarm | Rise range | Drop range |
|--------------|---------------|----------------------------------|------------|------------|
| 1 | 2mA | >2mA alarm R: range over | 2.2mA | 180uA |
| 2 | 200uA | >200uA no alarm R: range over | ↑ 220uA | ↓ 18uA |
| 3 | 20uA | >20uA no alarm R: range over | ↑ 22uA | ↓ 1.8uA |
| 4 | 2uA | >2uA no alarm R: range over | ↑ 2.2uA | ↓ 180nA |
| 5 | 200nA | >200nA no alarm R: range over | ↑ 220nA | ↓ 18nA |
| 6 | 20nA | >20nA no alarm R: range over | ↑ 22nA | ↓ 1.8nA |
| 7 | 2nA | >2nA no alarm R: range over | ↑ | ↓ |

4.3 Setting test parameters

Click [PAGE] on the test page to switch to the settings page, using the direction key to select the parameters to be set;

| MEAS | SET | SAVE | COM | SYS | |
|-----------|------------|------|-----|-----|-----|
| MEAS TIME | OFF | | | | OFF |
| CHG TIME | OFF | | | | ON |
| DISC TIME | OFF | | | | |
| RS | OFF | | | | |
| RV | OFF | | | | |
| DIGIT | 5 | | | | |
| BEEP MODE | PASS | | | | |
| MEAS MODE | CONT | | | | |

Measure timing: 000.0 s Set continuous test time in s.000.1-999.9

Charging delay: 000.0 s set charging time, delay range is 000.1-999.9 s, in single or continuous test mode will be based on charging time delay.

Discharge delay: 000.0 s set discharge time, delay range is 000.1-999.9 s, in single or continuous test mode will be based on discharge time delay.

Surface resistance: set surface resistivity parameters.

Volume resistance: set volume resistivity parameters.

Display bit: you can set the test interface resistance display bit 4 or 5.

Response mode: set response mode.

4.4 Clear circuit

1. press [0. ADJ] key to enter the ready zero interface. Remove or suspend the Input end and the voltage output Output end test clip before starting to clear.
2. Press the ENTER] key to start clearing ,[ESC] back to the measurement interface. The instrument clears zero, and in the automatic range, the instrument clears all ranges. In manual mode, the instrument only clears the current range. If the zero clearing is successful, the zero clearing data will be non-volatile memory.
3. The instrument automatically returns to the test state after

clearing.

| | |
|--|---|
|  CAUTION | Input and voltage output test lines must be open and suspended without contact with any object. |
|--|---|

| | | | | | |
|---|--------|--------|---------|-----------|-----------|
| MEAS | SET | SAVE | COM | SYS | RANG+ |
| VOLT | 1000 V | RANG | 1 | RANG AUTO | OFF |
| RATE | FAST | UP-LIM | 1000 TΩ | LO-LIM | 1.000 kΩ |
| <div style="background-color: black; color: white; padding: 10px; border: 1px solid gray;"> <p style="font-size: 2em; margin: 0;">R: 0 Ω</p> <p style="margin: 0;">V: -0.000v T: 0.0s</p> <p style="margin: 0;">SCOPE: 500.0k-50.0M</p> <div style="border: 1px solid gray; background-color: #333; color: white; padding: 5px; display: inline-block; margin: 5px 0;"> ZERO ENTER ESC </div> </div> | | | | | RANG- |
| | | | | | RANG AUTO |
| | | | | | RESET |

Chapter V Measurement Settings Save

Press the [PAGE] button twice on the measurement page to save the page ,[ESC] return to the measurement page.

| | | | | | |
|------|----------|------------|-------|-----|--------|
| MEAS | SET | SAVE | COM | SYS | SAVE |
| No. | Name | VOLT | 0050 | | |
| 01 | PANEL_01 | RANG | 6 | | LOAD |
| 02 | ----- | MEAS TIME | OFF | | |
| 03 | ----- | CHARG TIME | OFF | | |
| 04 | ----- | UP-LIM | ----Ω | | CLEAR |
| 05 | ----- | LO-LIM | ----Ω | | |
| 06 | ----- | BEEP MODE | PASS | | |
| 07 | ----- | | | | |
| 08 | ----- | | | | |
| 09 | ----- | | | | |
| 10 | ----- | | | | RENAME |

5.1 Save Measurement Settings

1. Press [F1] to save the current measurement parameters on the save page;

| MEAS | SET | SAVE | COM | SYS | | | | | | | | | | | | | | | | | | | | | | | | | | | | | | | | | | | | | | | | | | | | | |
|--|----------|-----------|------|-----|-----|------|------|------|----|----------|------|---|----|-------|-----------|-----|----|-------|--|--|----|-------|--|--|----|-------|--|---|----|-------|--|---|----|-------|-----------|------|----|-------|--|--|----|-------|--|--|----|-------|--|--|-----|
| <table border="1"> <thead> <tr> <th>No.</th> <th>Name</th> <th>VOLT</th> <th>0050</th> </tr> </thead> <tbody> <tr> <td>01</td> <td>PANEL_01</td> <td>RANG</td> <td>6</td> </tr> <tr> <td>02</td> <td>-----</td> <td>MEAS TIME</td> <td>OFF</td> </tr> <tr> <td>03</td> <td>-----</td> <td></td> <td></td> </tr> <tr> <td>04</td> <td>-----</td> <td></td> <td></td> </tr> <tr> <td>05</td> <td>-----</td> <td></td> <td>Ω</td> </tr> <tr> <td>06</td> <td>-----</td> <td></td> <td>Ω</td> </tr> <tr> <td>07</td> <td>-----</td> <td>BEEP MODE</td> <td>PASS</td> </tr> <tr> <td>08</td> <td>-----</td> <td></td> <td></td> </tr> <tr> <td>09</td> <td>-----</td> <td></td> <td></td> </tr> <tr> <td>10</td> <td>-----</td> <td></td> <td></td> </tr> </tbody> </table> | | | | | No. | Name | VOLT | 0050 | 01 | PANEL_01 | RANG | 6 | 02 | ----- | MEAS TIME | OFF | 03 | ----- | | | 04 | ----- | | | 05 | ----- | | Ω | 06 | ----- | | Ω | 07 | ----- | BEEP MODE | PASS | 08 | ----- | | | 09 | ----- | | | 10 | ----- | | | 0-9 |
| No. | Name | VOLT | 0050 | | | | | | | | | | | | | | | | | | | | | | | | | | | | | | | | | | | | | | | | | | | | | | |
| 01 | PANEL_01 | RANG | 6 | | | | | | | | | | | | | | | | | | | | | | | | | | | | | | | | | | | | | | | | | | | | | | |
| 02 | ----- | MEAS TIME | OFF | | | | | | | | | | | | | | | | | | | | | | | | | | | | | | | | | | | | | | | | | | | | | | |
| 03 | ----- | | | | | | | | | | | | | | | | | | | | | | | | | | | | | | | | | | | | | | | | | | | | | | | | |
| 04 | ----- | | | | | | | | | | | | | | | | | | | | | | | | | | | | | | | | | | | | | | | | | | | | | | | | |
| 05 | ----- | | Ω | | | | | | | | | | | | | | | | | | | | | | | | | | | | | | | | | | | | | | | | | | | | | | |
| 06 | ----- | | Ω | | | | | | | | | | | | | | | | | | | | | | | | | | | | | | | | | | | | | | | | | | | | | | |
| 07 | ----- | BEEP MODE | PASS | | | | | | | | | | | | | | | | | | | | | | | | | | | | | | | | | | | | | | | | | | | | | | |
| 08 | ----- | | | | | | | | | | | | | | | | | | | | | | | | | | | | | | | | | | | | | | | | | | | | | | | | |
| 09 | ----- | | | | | | | | | | | | | | | | | | | | | | | | | | | | | | | | | | | | | | | | | | | | | | | | |
| 10 | ----- | | | | | | | | | | | | | | | | | | | | | | | | | | | | | | | | | | | | | | | | | | | | | | | | |
| | | | | | A-Z | | | | | | | | | | | | | | | | | | | | | | | | | | | | | | | | | | | | | | | | | | | | |
| | | | | | a-z | | | | | | | | | | | | | | | | | | | | | | | | | | | | | | | | | | | | | | | | | | | | |
| | | | | | DEL | | | | | | | | | | | | | | | | | | | | | | | | | | | | | | | | | | | | | | | | | | | | |

2. use the direction key and [F1-F4] function key to enter the name ,[ENTER] confirm ,[ESC] cancel;

5.2 Call measurement settings

1. Use the upper and lower keys on the save page to select the filename to load;

| MEAS | SET | SAVE | COM | SYS | | | | | | | | | | | | | | | | | | | | | | | | | | | | | | | | | | | | | | | | | | | | | |
|---|----------|------------|-------|-----|--------|------|------|------|----|----------|------|---|----|-------|-----------|-----|----|-------|------------|-----|----|-------|--------|-------|----|-------|--------|-------|----|-------|-----------|------|----|-------|--|--|----|-------|--|--|----|-------|--|--|----|-------|--|--|------|
| <table border="1"> <thead> <tr> <th>No.</th> <th>Name</th> <th>VOLT</th> <th>0050</th> </tr> </thead> <tbody> <tr> <td>01</td> <td>PANEL_01</td> <td>RANG</td> <td>6</td> </tr> <tr> <td>02</td> <td>-----</td> <td>MEAS TIME</td> <td>OFF</td> </tr> <tr> <td>03</td> <td>-----</td> <td>CHARG TIME</td> <td>OFF</td> </tr> <tr> <td>04</td> <td>-----</td> <td>UP-LIM</td> <td>----Ω</td> </tr> <tr> <td>05</td> <td>-----</td> <td>LO-LIM</td> <td>----Ω</td> </tr> <tr> <td>06</td> <td>-----</td> <td>BEEP MODE</td> <td>PASS</td> </tr> <tr> <td>07</td> <td>-----</td> <td></td> <td></td> </tr> <tr> <td>08</td> <td>-----</td> <td></td> <td></td> </tr> <tr> <td>09</td> <td>-----</td> <td></td> <td></td> </tr> <tr> <td>10</td> <td>-----</td> <td></td> <td></td> </tr> </tbody> </table> | | | | | No. | Name | VOLT | 0050 | 01 | PANEL_01 | RANG | 6 | 02 | ----- | MEAS TIME | OFF | 03 | ----- | CHARG TIME | OFF | 04 | ----- | UP-LIM | ----Ω | 05 | ----- | LO-LIM | ----Ω | 06 | ----- | BEEP MODE | PASS | 07 | ----- | | | 08 | ----- | | | 09 | ----- | | | 10 | ----- | | | SAVE |
| No. | Name | VOLT | 0050 | | | | | | | | | | | | | | | | | | | | | | | | | | | | | | | | | | | | | | | | | | | | | | |
| 01 | PANEL_01 | RANG | 6 | | | | | | | | | | | | | | | | | | | | | | | | | | | | | | | | | | | | | | | | | | | | | | |
| 02 | ----- | MEAS TIME | OFF | | | | | | | | | | | | | | | | | | | | | | | | | | | | | | | | | | | | | | | | | | | | | | |
| 03 | ----- | CHARG TIME | OFF | | | | | | | | | | | | | | | | | | | | | | | | | | | | | | | | | | | | | | | | | | | | | | |
| 04 | ----- | UP-LIM | ----Ω | | | | | | | | | | | | | | | | | | | | | | | | | | | | | | | | | | | | | | | | | | | | | | |
| 05 | ----- | LO-LIM | ----Ω | | | | | | | | | | | | | | | | | | | | | | | | | | | | | | | | | | | | | | | | | | | | | | |
| 06 | ----- | BEEP MODE | PASS | | | | | | | | | | | | | | | | | | | | | | | | | | | | | | | | | | | | | | | | | | | | | | |
| 07 | ----- | | | | | | | | | | | | | | | | | | | | | | | | | | | | | | | | | | | | | | | | | | | | | | | | |
| 08 | ----- | | | | | | | | | | | | | | | | | | | | | | | | | | | | | | | | | | | | | | | | | | | | | | | | |
| 09 | ----- | | | | | | | | | | | | | | | | | | | | | | | | | | | | | | | | | | | | | | | | | | | | | | | | |
| 10 | ----- | | | | | | | | | | | | | | | | | | | | | | | | | | | | | | | | | | | | | | | | | | | | | | | | |
| | | | | | LOAD | | | | | | | | | | | | | | | | | | | | | | | | | | | | | | | | | | | | | | | | | | | | |
| | | | | | CLEAR | | | | | | | | | | | | | | | | | | | | | | | | | | | | | | | | | | | | | | | | | | | | |
| | | | | | RENAME | | | | | | | | | | | | | | | | | | | | | | | | | | | | | | | | | | | | | | | | | | | | |

2. Load the selected file by [F2] on the save page, press ENTER] to confirm, [ESC] cancel.

| MEAS | | SET | SAVE | COM | SYS |
|------|----------|-----------|------|-----|-----|
| No. | Name | VOLT | 0050 | | |
| 01 | PANEL_01 | RANG | 6 | | |
| 02 | ----- | MEAS TIME | OFF | | |
| 03 | ----- | | | | |
| 04 | ----- | | | Ω | |
| 05 | ----- | | | Ω | |
| 06 | ----- | | | | |
| 07 | ----- | BEEP MODE | PASS | | |
| 08 | ----- | | | | |
| 09 | ----- | | | | |
| 10 | ----- | | | | |

5.3 Delete measurement settings

1. Use the upper and lower keys on the save page to select the file name to clear;

| MEAS | | SET | SAVE | COM | SYS | |
|------|----------|------------|-------|-----|-----|--------|
| No. | Name | VOLT | 0050 | | | SAVE |
| 01 | PANEL_01 | RANG | 6 | | | LOAD |
| 02 | ----- | MEAS TIME | OFF | | | |
| 03 | ----- | CHARG TIME | OFF | | | |
| 04 | ----- | UP-LIM | ----Ω | | | |
| 05 | ----- | LO-LIM | ----Ω | | | CLEAR |
| 06 | ----- | BEEP MODE | PASS | | | |
| 07 | ----- | | | | | |
| 08 | ----- | | | | | |
| 09 | ----- | | | | | |
| 10 | ----- | | | | | RENAME |

2. On the save page press [F3] clear, press [ENTER] confirm, [ESC] cancel;

| MEAS | SET | SAVE | COM | SYS |
|------|----------|-----------|------|-----|
| No. | Name | VOLT | 0050 | |
| 01 | PANEL_01 | RANG | 6 | |
| 02 | ----- | MEAS TIME | OFF | |
| 03 | ----- | | | |
| 04 | ----- | | | Ω |
| 05 | ----- | | | Ω |
| 06 | ----- | BEEP MODE | PASS | |
| 07 | ----- | | | |
| 08 | ----- | | | |
| 09 | ----- | | | |
| 10 | ----- | | | |

PRESS ENTER TO CLEAR

5.4 Rename measurement settings

1. Use the upper and lower keys on the save page to select the filename to load;

| MEAS | SET | SAVE | COM | SYS | |
|------|----------|------------|-------|-----|--------|
| No. | Name | VOLT | 0050 | | SAVE |
| 01 | PANEL_01 | RANG | 6 | | |
| 02 | ----- | MEAS TIME | OFF | | LOAD |
| 03 | ----- | CHARG TIME | OFF | | |
| 04 | ----- | UP-LIM | ----Ω | | |
| 05 | ----- | LO-LIM | ----Ω | | CLEAR |
| 06 | ----- | BEEP MODE | PASS | | |
| 07 | ----- | | | | |
| 08 | ----- | | | | |
| 09 | ----- | | | | |
| 10 | ----- | | | | RENAME |

2. In the save page press [F4] rename, use the direction key and [F1-F4] function key to enter the name ,[ENTER] confirm ,[ESC] cancel.

| MEAS | | SET | | SAVE | | COM | | SYS | |
|------|----------|-----------|----------|------|------|-----|--|-----|--|
| | | Name | | VOLT | 0050 | 0-9 | | | |
| 01 | PANEL_01 | RANG | 6 | A-Z | | | | | |
| 02 | ----- | MEAS TIME | OFF | a-z | | | | | |
| 03 | ----- | NAME | | DEL | | | | | |
| 04 | ----- | | PANEL_01 | | | | | | |
| 05 | ----- | | | | | | | | |
| 06 | ----- | | | | | | | | |
| 07 | ----- | BEEP MODE | PASS | | | | | | |
| 08 | ----- | | | | | | | | |
| 09 | ----- | | | | | | | | |
| 10 | ----- | | | | | | | | |

Chapter VI EXT I/O interface (Handler)

The EXT I/O terminal on the rear panel of the instrument supports external control, provides the output of the test and comparison judgment signal, and accepts the input TRG signal. All signals use an optical coupler. Through the instrument panel setting, understanding the internal circuit structure and paying attention to safety matters is conducive to better connection control system.

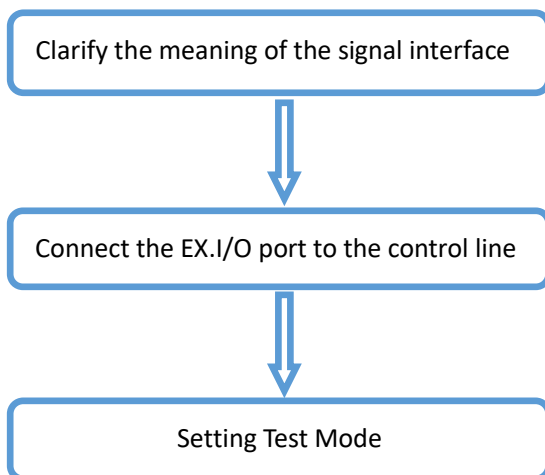

6.1 EXT I/O ports and signals

During this section, you will learn about the connection and introduction of the EXT I/O.



Do not plug EXT I/O ports during testing

Do not connect IO port to test end

Input schematic diagram

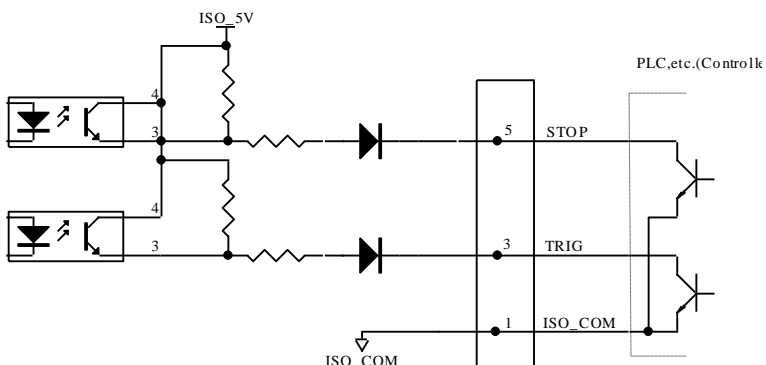

Output schematic

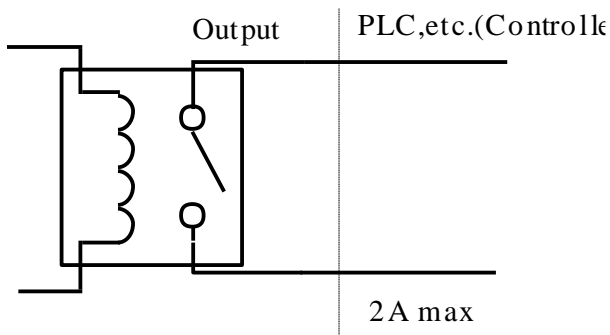

6.1.1 Port signal details

Port and signal description

EXT I/O port connector adopts 9- Pin D-SUB foot bus terminal.

Figure:

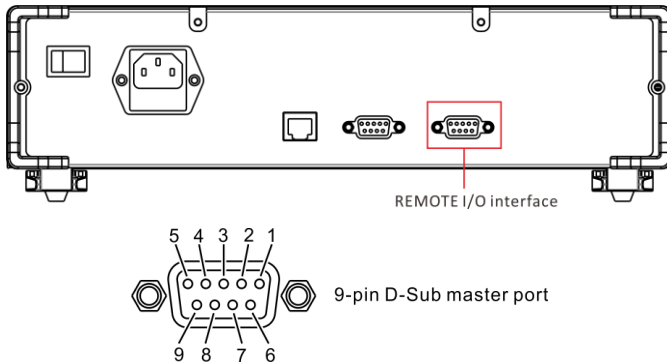

Port Details

(Instrument end)

| Serial number | Terminal name | Meaning |
|---------------|---------------|------------------------------------|
| 6, 7 | NG | Unqualified output relay on signal |
| 8, 9 | GD | Qualified output relay on signal |
| 1 | GND | Segregation |
| 3 | TRG | External trigger signal |
| 5 | STOP | External stop signal |



- in order to avoid damaging the interface, do not exceed the power supply requirements.
- In order to avoid damage to the interface, please connect after the instrument is closed.
- If the output signal user is used to control the relay, the relay must use a reverse energy release diode.

6.1.2 Port Signal Connection Mode

Electrical performance parameters

Output signal: relay switch output.

Maximum load voltage 30 V.

Maximum output current: 2 A.

Input signal: photoelectric isolation.

Low level valid.

Maximum current :50 mA.

Input circuit connection

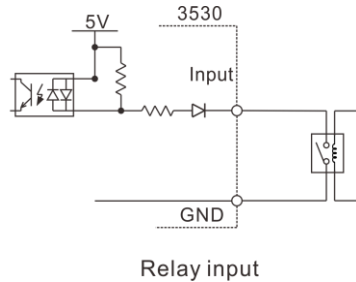
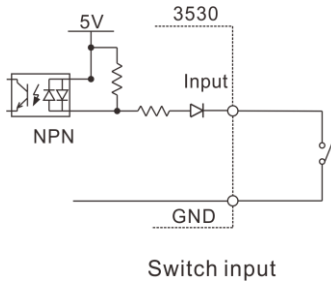

Output circuit connection

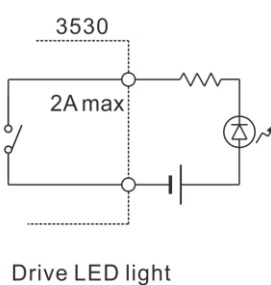
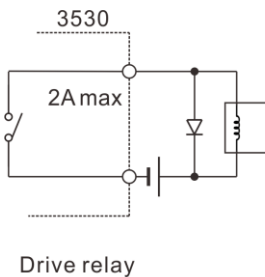

6.2 Sequence diagram

Each signal level represents the ON/OFF state of the contact, and the upper horizontal bar represents the low level effective.

6.2.1 Sequence diagram of external trigger

External trigger [EXT] set (I/O output mode to hold)

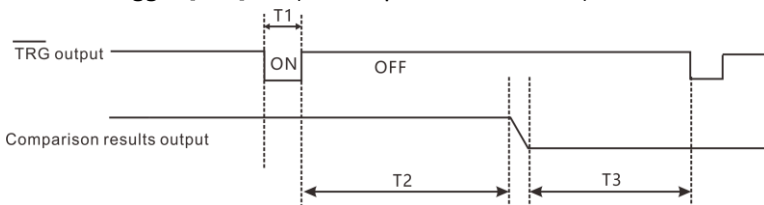

T1: Minimum $\overline{0.5\text{ms}}$ drop edge trigger

T2: Minimum 200mS(measurement time)

T3: Remain until the next trigger

| | Project | Time |
|----|-------------------------|------------------------------|
| T1 | TRG, signal pulse width | 5mS_{MIN} |
| T2 | ADC sampling time | speed 200 ms slow 1000 ms |
| T3 | Sorting output | 1mS_{MAX} |

6.2.2 Read flow when triggered externally

The following is the process from the start of the measurement to the acquisition of the measured value when using an external trigger.

Determine the result of this instrument (GD、NG). When the response of the controller input circuit is slow, the waiting time is needed from the detection signal to the reading result.

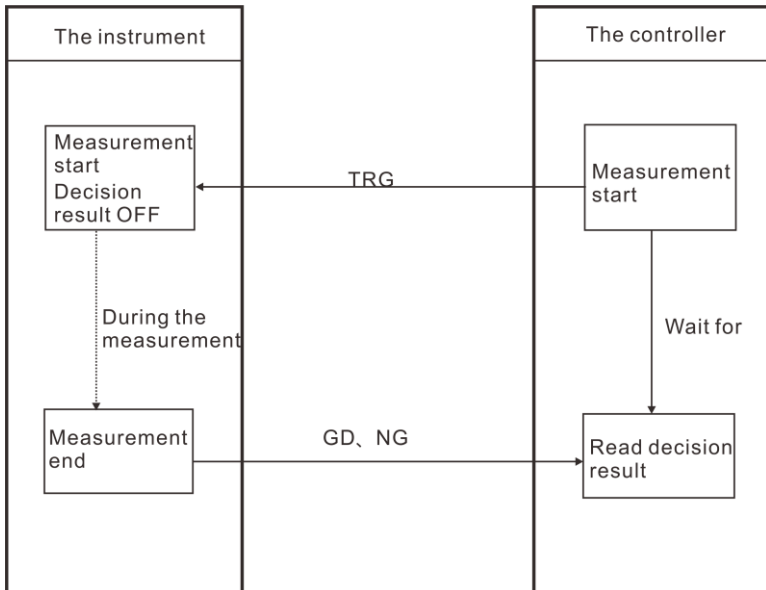

Chapter VII Communications

The instrument provides two communication modes, RS232C、LAN (Ethernet protocol adopts TCP protocol) communication mode. Instrument provides SCPI communication protocol. The instruction set in the communication instruction reference manual.



It is forbidden to connect the communication port to the test port, otherwise the instrument will be damaged.

7.1 RS232 Communication Mode

RS232 communication mode adopts 3 line communication mode respectively.

7.1.1 Interface and Cable

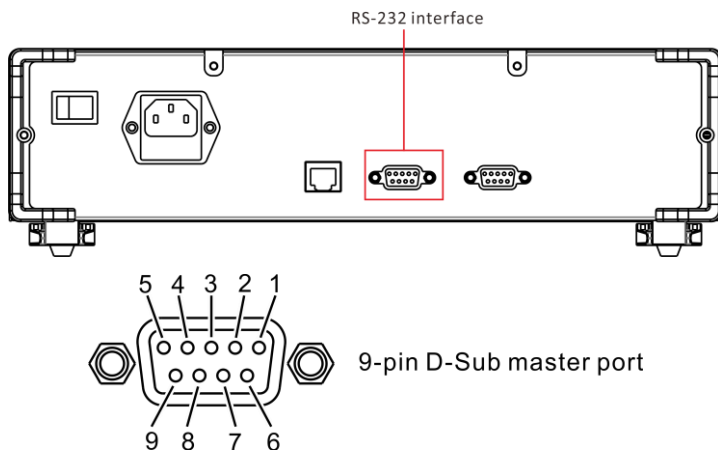

return to the measurement page.

7.2 LAN Communication Mode

LAN communication adopts TCP protocol communication.

7.2.1 Interface and Cable

Ethernet interface adopts standard RJ45 port, cable adopts more than 5 kinds of network cable.

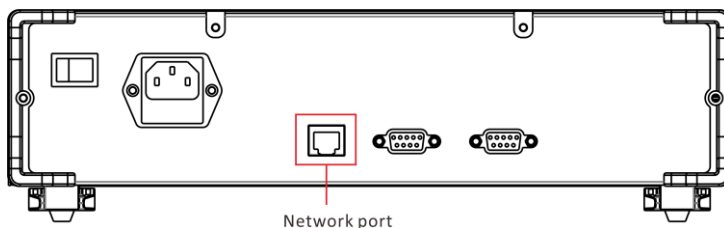

7.2.2 LAN Connection Mode

Instrument and computer connection

When the instrument and computer are connected, the network wire adopts cross line.

A termination connection method adopts 568 B standard:

| | | | | | | | |
|--------------|--------|-------------|------|------------|-------|-------------|-------|
| Orange white | Orange | Green white | Blue | Blue White | Green | Brown white | Brown |
|--------------|--------|-------------|------|------------|-------|-------------|-------|

B termination connection method adopts 568 A standard:

| | | | | | | | |
|-------------|-------|--------------|------|------------|--------|-------------|-------|
| Green white | Green | Orange white | Blue | Blue White | Orange | Brown white | Brown |
|-------------|-------|--------------|------|------------|--------|-------------|-------|

Instrument and router connection

When the instrument and router are connected, the network wire is connected directly.

568 B at both ends:

| | | | | | | | |
|--------------|--------|-------------|------|------------|-------|-------------|-------|
| Orange white | Orange | Green white | Blue | Blue White | Green | Brown white | Brown |
|--------------|--------|-------------|------|------------|-------|-------------|-------|

7.2.3 LAN Communications Settings

1. Select the newsletter page

Press [PAGE] key 3 times in the test interface, switch to the communication page, press [F2] to select TCP communication mode;

| | | | | | |
|----------|-----------------|------|-----|-----|-------|
| MEAS | SET | SAVE | COM | SYS | RS232 |
| COM MODE | TCP | | | | TCP |
| RADIO | OFF | | | | |
| IP | 000.000.000.000 | | | | |
| PORT | 502 | | | | |

2. Choose broadcast mode using directional key, press [F1]、[F2] select open / close, broadcast mode open, test data automatically upload;

3. Select the address on the communication page ,[ENTER] input, direction key set address, set after [ENTER] OK ,[ESC] return;

7.3 USB interface

The front panel of the instrument has a USB interface, which is used as a HOST function, inserted into the U disk for upgrading programs and saving data or settings.

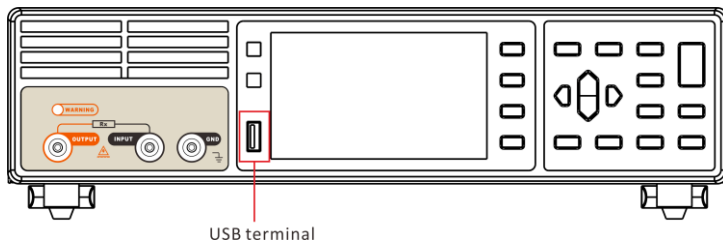

Chapter VIII Parameters

8.1 General parameters

General functions:

| | |
|------------------------------------|--|
| Measurement parameters | Insulation resistance R, leakage current I, surface resistance Rs, bulk resistance |
| Scope of testing | 500Ω~9.9X1015Ω, 2mA ~ 0.01pA |
| Test speed (MAX) | Fast 5 times per second, slow 1 time per second |
| Readback voltage accuracy | 0.5% (> 10V), 1% (≤10V) |
| Range Overlimit Display | Super range |
| Input terminals | Banana plug, BNC plug |
| Operating key | Rubber bond |
| Display | 4.3 inch TFT |
| Precision Guarantee Period | 1 year |
| Operating temperature and humidity | 0°C to 40°C below 80 RH (no condensation) |
| Storage temperature and humidity | -10°C to 60°C below 80 RH (no condensation) |
| Operating environment | Indoor, highest altitude m 2000 |
| Power supply | Voltage :198 V ~240 V AC Frequency :47 Hz/63Hz |
| Power consumption | 50 W |
| Size | About 331 mm x 329mm x 80mm |
| Weight | Approximately 4.1 kg |

8.2 Accuracy

Test conditions for the following indicators:

Temperature: $20 \pm 3^{\circ}\text{C}$; Humidity: $< 80\% \text{RH}$;

Preheating more than 15 minutes

Calibration within 1 year

HT3530/HT3530A:

Insulation resistance: take 11 points typical voltage value, accuracy 1%(less than 1 G); 3%(1 G -10 G); 5%(10 G -100 G); 10%(100 points -1 T); 20%(more than 1 T).

| Range Voltage | 1 | 2 | 3 | 4 | 5 | 6 | 7 |
|------------------|------------|------------|------------|------------|------------|------------|--------------|
| 1V | 0.5K-50K | 5K-500K | 50K-5M | 500K-50M | 5M-500M | 50M-5G | 500M-100T |
| 10V | 5K-500K | 50K-5M | 500K-50M | 5M-500M | 50M-5G | 500M-50G | 5G-1000T |
| 25V | 12.5K-1.2M | 125K-12.5M | 1.2M-125M | 12.5M-1.2G | 125M-12.5G | 1.2G-125G | 12.5G-2500T |
| 50V | 25K-2.5M | 250K-25M | 2.5M-250M | 25M-2.5G | 250M-25G | 2.5G-250G | 25G-5000T |
| 75V | 37.5K-3.8M | 375K-37.5M | 3.8M-375M | 37.5M-3.8G | 375M-37.5G | 3.8G-375G | 37.5G-7500T |
| 100V | 50K-5M | 500K-50M | 5M-500M | 50M-5G | 500M-50G | 5G-500G | 50G-10000T |
| 125V | 62.5K-6.2M | 625K-62.5M | 6.2M-625M | 62.5M-6.2G | 625M-62.5G | 6.2G-625G | 62.5G-12500T |
| 250V | 125K-12.5M | 1.2M-125M | 12.5M-1.2G | 125M-12.5G | 1.2G-125G | 12.5G-1.2T | 125G-25000T |
| 500V | 250K-25M | 2.5M-250M | 25M-2.5G | 250M-25G | 2.5G-250G | 25G-2.5T | 250G-50000T |
| 750V | 375K-37.5M | 3.8M-375M | 37.5M-3.7G | 375M-37.5G | 3.7G-375G | 37.5G-3.8T | 375G-75000T |
| 1000V | 500K-50M | 5M-500M | 50M-5G | 500M-50G | 5G-500G | 50G-5T | 500G-10000T |

j

This specification is edited and revised by HOPETECH Technology Department, version number V1.3.

If the specification is incorrect or unreasonable, please contact us. Welcome to call for technical consultation.

Manufacturer: Changzhou HOPETECH Electronic Technology Co., Ltd
Address :5/F, Block A ,88 Taihu West Road, Xinbei District, Changzhou
Tel: 0519-89852525 Fax: 0519-89853517

Website: www.hopeinstrument.com

- If contact information changes, please pay attention to our website.
- The copyright and interpretation of this specification are owned by our company.