

Operation Manual

TH2518/A

Resistance/Temperature Scanner

Content

CHAPTER 1 INSTRUMENT INTRODUCTION AND UNPACKING CHECK	5
1.1 INSTRUMENT INTRODUCTION	5
1.2 UNPACKING AND INSPECTION	5
1.3 POWER CONNECTION	5
1.4 FUSE	6
1.5 ENVIRONMENT	6
1.6 TEST FIXTURE	6
1.7 PREHEATING	6
1.8 OTHER FEATURES OF THE INSTRUMENT	6
CHAPTER 2 FRONT AND REAR PANEL DESCRIPTIONS AND INITIAL OPERATION	7
2.1 FRONT PANEL DESCRIPTION	7
2.2 REAR PANEL DESCRIPTION	8
2.3 DEFINITION OF THE MEASUREMENT DISPLAY AREA	9
2.3.1 Stand-alone Mode (Alone)	9
2.3.2 Scan Mode (Scan)	10
2.4 MAIN MENU BUTTONS	11
2.4.1 Measurement Display MEAS	11
2.4.2 Parameter Setting SETUP	11
2.4.3 System Settings SYSTEM	11
2.5 BASIC OPERATION	12
2.6 POWER ON	12
CHAPTER 3 BASIC OPERATION	14
3.1 MEASUREMENT DISPLAY	14
3.1.1 Stand-alone Mode	14
3.1.2 Scanning Mode	18
3.2 MEASUREMENT SETTINGS	19
3.2.1 Measured Parameter	19
3.2.2 Measurement Speed	19
3.2.3 Trigger Mode	19
3.2.4 0 ADJ	20
3.2.5 Measurement Delay	20
3.2.6 Range (R)	20
3.2.7 Temperature Compensation	20
3.2.8 Average	20
3.2.9 Transducers	21
3.2.10 Sorting Mode	22
3.3 BOUNDARY SETTINGS	22
3.3.1 Alone Mode	22
3.3.2 Scan Mode	23
3.4 CHANNEL SETTINGS (SCAN MODE)	24
3.5 JUNCTION BOX AND SCANNING	25
3.5.1 Junction Box (accessory)	25
3.5.2 Scanning	25
CHAPTER 4 SYSTEM SETTINGS AND FILE MANAGEMENT	26
4.1 SYSTEM SETTINGS	26
4.1.1 Measurement Mode	26
4.1.2 Language	26
4.1.3 Password	27
4.1.4 Touch Tone	27
4.1.5 Bus Mode	27
4.1.6 Baud Rate	28
4.1.7 Power Frequency	28
4.1.8 Handler Power Supply	28
4.1.9 Shift Output	28
4.1.10 232 Address	28

4.1.11	Record-keeping	28
4.1.12	Base-to-valve Ratio	29
4.1.13	Time and Date Setting	29
4.1.14	Artifact.....	29
4.1.15	232 Protocol	30
4.1.16	FetcAuto.....	30
4.1.17	Hdl Time	30
4.2	DOCUMENT MANAGEMENT	30
4.2.1	Introduction to Store/Recall Functions	31
4.2.2	Folder/file Structure on USB Flash Drive	31
4.2.3	File Management Procedure.....	32
4.2.4	Storage of Measurement Results.....	33
CHAPTER 5 PERFORMANCE INDICATORS		34
5.1	MEASUREMENT FUNCTION	34
5.1.1	Measurement Parameters and Symbols	34
5.1.2	Measurement Mode.....	34
5.1.3	Measurement Combinations	34
5.1.4	Range.....	34
5.1.5	Trig.....	34
5.1.6	Test End Approach	34
5.1.7	Average.....	34
5.2	TEST SIGNAL.....	35
5.2.1	Ranging Current.....	35
5.2.2	Open Output Voltage	35
5.2.3	Maximum Range of Measurement Display	35
5.3	MEASUREMENT ACCURACY.....	35
5.3.1	Resistance Scanning Measurement Accuracy	35
5.3.2	Temperature Measurement Accuracy (PT500, PT100).....	36
5.3.3	Temperature Measurement Accuracy (Analog Input).....	36
5.3.4	Temperature Correction Factor K	36
CHAPTER 6 REMOTE CONTROL		37
6.1	RS232C INTERFACE DESCRIPTION.....	37
6.2	LAN REMOTE CONTROL SYSTEM.....	37
6.2.1	Network Protocol	38
6.2.2	DHCP	38
6.2.3	Port Number	38
6.2.4	IP Address	39
6.2.5	Subnet Mask.....	39
6.2.6	Gateway	39
6.3	USBTMC REMOTE CONTROL SYSTEM	39
6.3.1	System Configuration	39
6.3.2	Installation of Drivers.....	39
6.4	USBVCOM VIRTUAL SERIAL PORT.....	40
6.4.1	System Configuration	40
6.4.2	Installation of Drivers.....	40
CHAPTER 7 TH2518 COMMAND SET		42
7.1	SCPI COMMAND SET	42
7.1.1	DISP Command Set.....	42
7.1.2	FUNC Command Set.....	43
7.1.3	APER Command Set	45
7.1.4	TRIG Command Set.....	46
7.1.5	FETC Command Set	48
7.1.6	TEMP Command Set.....	50
7.1.7	COMP Command Set	52
7.1.8	CHAN<n> Command Set	60
7.1.9	SYST command set.....	68
7.1.10	SCPI Public Command	71
7.2	SCPI PROTOCOL DEBUGGING	72
7.2.1	Instrument Settings.....	72

7.2.2	Debugging Assistant Download.....	72
7.2.3	Instrument Commissioning	72
7.2.4	Getting Measurement Results.....	73
7.3	MODBUS SYSTEM COMMANDS	74
7.3.1	MODBUS Protocol Description	74
7.3.2	Public Command Description.....	77
7.3.3	DISP Command Description	79
7.3.4	FUNC Command Description	81
7.3.5	APER Command Description.....	86
7.3.6	TRIG Command Description.....	87
7.3.7	FETC Command Description	90
7.3.8	TEMP Command Description	95
7.3.9	COMP Command Description	98
7.3.10	CHAN Command Description	113
7.3.11	SYST Command Description	126
7.1	MODBUS PROTOCOL DEBUGGING	130
7.4.1	Instrument Settings.....	130
7.4.2	Instrument Commissioning	130
7.4.3	Getting Measurement Results.....	131
7.5	MODBUS COMMANDS DETAILED DESCRIPTION	133
7.5.1	Send Address and Command Address	133
7.5.2	Data byte 1~n	133
7.5.3	CRC Low and CRC High.....	134
7.5.4	Return Command Format.....	135
7.5.5	Actual Example	135
CHAPTER 8 HANDLER INTERFACE USAGE NOTES		137
8.2	HANDLER PORTS AND SPECIFIC MEANINGS	137
8.2	HANDLER TIMING DIAGRAM.....	138
8.2.1	Stand-alone Mode	138
8.2.2	Scanning Mode	139
8.2.3	Shift Output Timing of Comparison Results for Each Test Channel	140
8.2.4	Electrical Characteristics	141
8.3	CHANNEL COMPARISON SORTING BOARD-TH2518-01	141
8.3.1	Introduction to Sorting Board.....	141
8.3.2	Sorting Board Ports and Port Description	142
8.3.3	Cascade of Sorting Board	143
8.3.4	Sorting Mode OneToOne	143
8.3.5	Sorting Mode SHIFT	145
8.3.6	Sorting Board Shift Output Signal Sketch	146
8.3.7	Precautions for Use	147
8.2	SCANNING PLUG-IN BOARD PIN INTERFACE DESCRIPTION	147
CHAPTER 9 PACKAGES & WARRANTY		148
9.1	PACKAGES	148
9.2	OPTION	148
9.3	SYMBOL	148
9.4	PACKAGING	148
9.5	TRANSPORTATION	148
9.6	STORAGE.....	149
9.7	WARRANTY.....	149
CHAPTER 10 APPENDIX		150
10.1	FIRMWARE UPGRADE	150
10.1.1	TH2518 Upgrade.....	150
10.1.2	TH2518A Upgrade	150
10.1.3	Upgrade Matters.....	150
10.2	MANUAL CHANGE COMMANDS.....	150

Chapter 1 Instrument Introduction and Unpacking Check

Thank you for purchasing and using our products! This chapter introduces you to the basic features of the instrument, and then describes some of the checks that must be made when you receive the instrument, and the conditions that must be understood before using it.

1.1 Instrument Introduction

TH2518 series application of synchronous plug-in design concept, support for the plug-in board test unit up to 6, and between the plug-in board to achieve synchronous measurement, greatly improving the scanning and measurement speed. Each plug-in board can be composed of up to 15 test channels, the combination of measurement methods between the channels to support user-programmable, the machine can be configured up to a maximum of 90 resistance / temperature scanning measurements, each measurement channel can be individually designed to select the comparison of the boundary as well as the output of the comparison of the selection signal. Temperature measurement of the sampling method can be configured for PT500 platinum resistance, PT100 platinum resistance, analog voltage input for different applications in three ways. 0.05% of the highest resistance accuracy, in the 200m Ω range, the resistance resolution is to achieve the level of 10u Ω , test scanning ranges from 10u Ω to 200k Ω .

The temperature compensation and temperature conversion function of the instrument makes the product testing free from the influence of ambient temperature, and it can output the comparison and sorting results of the whole machine level, board level as well as each channel, which makes your testing and data analysis and processing, and the sorting of the products easier. The standard RS232, USB HOST, USB Device, LAN and HANDLER interfaces make it convenient for you to save measurement data quickly and control the instrument remotely. The 24-bit color LCD page with touch function and 480 x 272 resolution brings you a different feeling of measurement operation!

1.2 Unpacking and Inspection

After opening the box, you should first check whether the instrument is damaged because of transportation, we do not recommend you power up the instrument under the condition of broken appearance.

Please confirm according to the packing list, if there is any discrepancy you can contact our company or distributor as soon as possible to maintain your rights and interests.

1.3 Power Connection

- 1) Supply voltage range: 90~125V, 190~250V.
- 2) Power supply frequency: 50Hz and 60Hz.
- 3) Power supply range: not more than 30VA.
- 4) The power input phase line L, zero-line N and bottom-line E should be the same as the power plug of this instrument.
- 5) This instrument has been carefully designed to minimize spurious interference due to inputs from the AC power supply side, however, it should still be used in as low a noise environment as possible, and if this cannot be avoided, install a power supply filter.

WARNING: In order to prevent the leakage of electricity from causing harm to the instrument or people, the user must ensure that the ground wire of the power supply is reliably connected to the earth. There is a 110V and 220V switch next to the power connector on the rear panel, pay attention to the correct switching.

1.4 Fuse

The instrument is equipped with a fuse from the factory, and the user should use the fuse provided by our company.

1.5 Environment

- 1) Please do not use it under dusty, vibration, direct sunlight or corrosive gas.
- 2) Instrument working environment conditions.

Temperature: 0°C~40°C, humidity: ≤80%RH, no condensation

- 3) Instrument storage environment conditions

Temperature: -10°C~50°C, Humidity: ≤90%RH, no condensation.

- 4) To ensure good ventilation of this tester, do not block the side ventilation holes so that the accuracy of the tester can be assured.
- 5) This instrument has been carefully designed to minimize spurious interference due to inputs from the AC power supply side, then it should still be used in as low a noise environment as possible, and if this cannot be avoided, install a power supply filter.
- 6) The instrument and especially the test leads connected to the part under test should be kept away from strong electromagnetic fields so as not to interfere with the measurement.

1.6 Test Fixture

Please use the test fixture or test cable equipped by our company, **user-made or other companies' test fixture or test cable may lead to incorrect measurement results.** Instrument test fixtures or test cables should be kept clean, and the pins of the device under test should also be kept clean to ensure good contact between the device under test and the test fixture.

Connect the test fixture or test cable to the corresponding test terminal on the front panel of the instrument. Note that the fixture plug should be the same color and arrow position as on the instrument panel, otherwise it may cause measurement abnormality.

1.7 Preheating

To ensure accurate measurement of the instrument, the power-on warm-up time should be not less than 30 minutes.

Do not switch the instrument on and off frequently as this may cause internal data confusion.

1.8 Other Features of the Instrument

- 1) Power consumption: ≤30VA.
- 2) Overall dimensions (W*H*D): 280mm*88mm*420mm.
- 3) Weight: about 7.5kg.

Chapter 2 Front and Rear Panel Descriptions and Initial Operation

This chapter describes the basic operating procedures of the TH2518 instrument. Before using the TH2518 instrument, please read this chapter in detail so that you can quickly learn the operation of the TH2518 instrument.

2.1 Front Panel Description

Figure 2-1 provides a brief description of the TH2518 front panel.

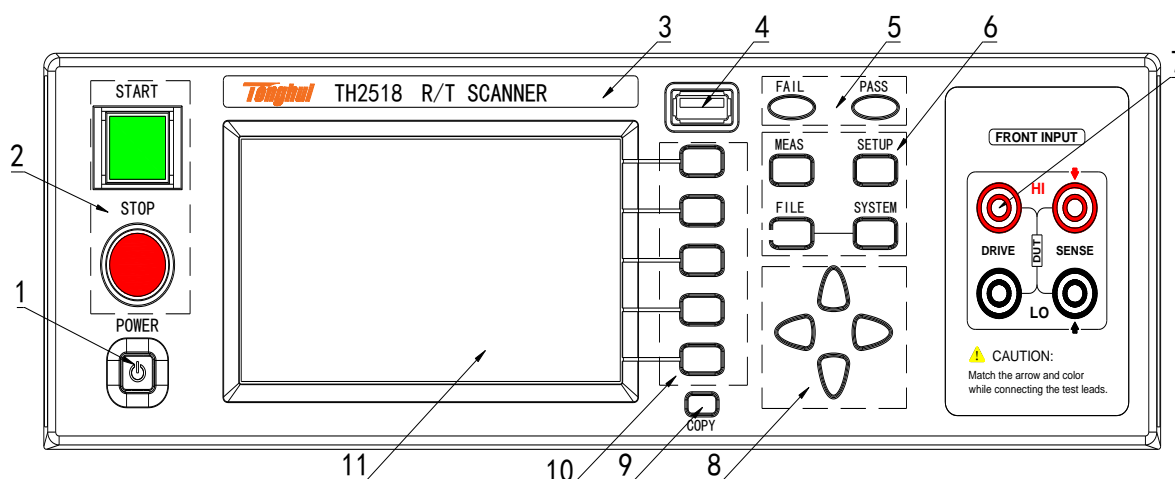

Figure 2-1 Front Panel Description

1) Power switch (POWER)

Power switch

2) External trigger key (START) and test reset key (STOP)

In scanning mode (Scan), when the trigger mode is internal (INT) or manual (MAN), START is used to trigger a scanning measurement; STOP is used to stop the current scanning, leaving the instrument in an idle state.

In stand-alone mode (Alone), when the trigger mode is manual (MAN), START is used to trigger a single stand-alone measurement; STOP is reserved.

3) Trademarks & Models

Instrument Trademarks and Models

4) USB port

The HOST port of USB is used to connect to USB flash drive memory for saving and recalling files.

5) PASS indicator and FAIL indicator

In the scanning mode (Scan), the PASS lamp lights when the comparison status is turned on and all open scanning channels pass the test, otherwise the FAIL lamp lights.

In stand-alone mode (Alone), PASS is on when the comparison status is on and the front panel test passes, otherwise FAIL is on.

6) main menu key

The four main menu keys are backlit when pressed.

MEAS key, "Measurement display" page: "Measurement display" page in scanning mode and "Measurement display page" in stand-alone mode.

SETUP key, "Parameter Setting" interface: there are two levels of "Measurement Setting", "Channel Setting", "Boundary Setting" and other options. There are two levels of "Measurement Settings", "Channel Settings", "Boundary Settings" and other options. The relevant options are different in stand-alone mode and scanning mode.

SYSTEM key, "System Settings" interface.

The **FILE** key brings you to the "File Management" page. There are two levels of internal and external file options.

7) Front Panel Test End (FRONT INPUT)

Four-terminal test end. Used to connect a four-terminal test cable to perform stand-alone mode (Alone) measurements on the DUT.

The plug color and arrow indication of the test cable should correspond to the jacks on the panel, otherwise it will not be measured correctly. When the test function is T and the temperature sensor is Analog, only two SENSE terminals are used, the high end of the voltage is input to the red terminal and the low end to the black terminal.

8) arrow key

Up, down, left, right and four direction buttons.

9) COPY key

Copy page button

10) Options soft key

Each option softkey has a corresponding function definition on the left side, which can be selected by touching the page in addition to the corresponding option key. The softkey definitions change depending on the page displayed.

11) LCD color liquid crystal display

A 24-bit color 4.3-inch color TFT LCD with touch function and 480 x 272 pixels resolution is used for setting test conditions and displaying measurement results, etc.

2.2 Rear Panel Description

Figure 2-2 provides a brief description of the TH2518 rear panel.

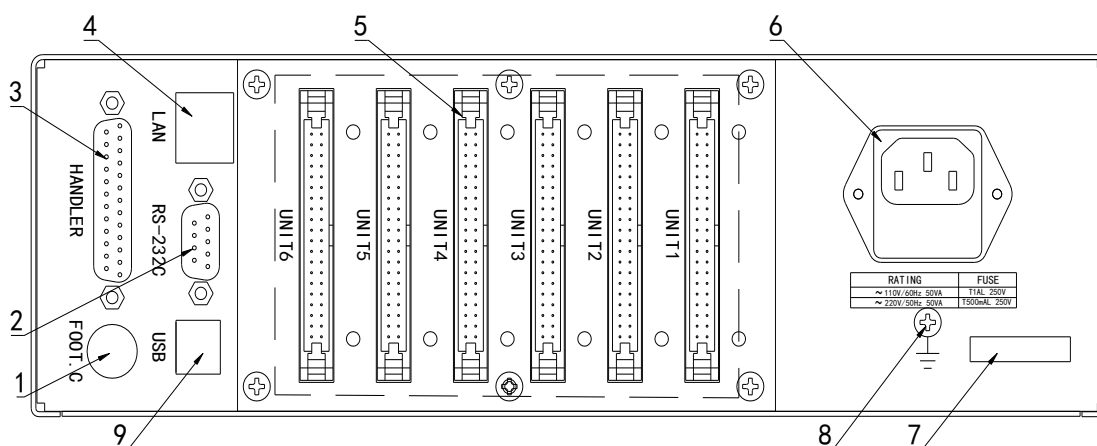

Figure 2-2 Rear Panel Description

1) Foot switch interface

The footswitch interface is used to trigger a primary measurement.

2) RS232C serial interface

Serial communication interface to realize on-line communication with computer.

3) HANDLER interface

Through the HANDLER interface, it is convenient to form an automatic test system and realize automatic test. The instrument outputs the comparison result signal and contact signal through this interface, and at the same time, external trigger signals can be input through this interface.

4) LAN interface

Network interface to realize the control and communication of the network system.

5) Plug-in board test cell

Up to 15 scanning channels are supported within each measurement board, and the combination of measurements between channels supports user-programmable configurations of up to 90 resistance/temperature scanning measurements.

6) Fuses and power outlets

Used for installing power fuse to protect the instrument, the direction of replacing the inner core can be switched 110V/220V; used for inputting AC power.

7) nameplate

Indicates date of manufacture, instrument number, and manufacturer.

8) grounding terminal

This terminal is connected to the metal outer enclosure of the instrument. It is used for protective or shielding ground connections.

9) USB DEVICE interface

USB communication interface to realize on-line communication with computer.

2.3 Definition of the Measurement Display Area

The TH2518 adopts a 24-bit color 4.3-inch color LCD with touch function and its resolution is 480*272. It is divided into two modes as follows:

2.3.1 Stand-alone Mode (Alone)



Figure 2-3 Measurement display area in Alone mode

1) Main menu area

This area indicates the name of the page currently being manipulated.

2) Functional area

This area is used to modify the test mode and test parameters.

3) Softkey area

This area is used to display the function menu corresponding to the cursor area.

4) Message alert area

This area is used to display various prompt display messages during system testing.

5) Measurement result display area

This area shows the display of measurement results such as resistance and temperature.

When the measurement parameter is R or T, the resistance or temperature entered at the front panel is tested, and any unit from Unit 1 to Unit 6 can be selected for measurement.

When the measurement parameter is R-T, R is the resistance of the front panel input and T is the value of the rear panel CH01 channel test.

2.3.2 Scan Mode (Scan)



Figure 2-4 Scanning Display Area in Scan Mode

1) Test Channel Identification

A green square box means this scan channel is on; a white square box means this scan channel is off.

In scanning mode, **Parameter Setting** → **Measurement Setting** → **Channel Setting** to set the channel on/off, as well as to set any test end of any test unit for 90 scanning channel users.

2) Main menu area

This area indicates the name of the page currently being manipulated.

3) Artifact

Inside are the display of scanning results (ON/OFF), 0 ADJ's (ON/OFF), execution of 0 ADJ (0 calibration function), and saving of data.

4) Scanning the pages of test results

Scanning mode, scanning display interface, the instrument can be configured to use up to 90 channels for scanning. 16 scanning display channels per page, with this arrow to page through the scanning results, for a total of 6 pages.

5) Display area for scanning results

Scanning test results for each test channel.

In scan mode, with temperature compensation off, both R and R-T are resistor values for the rear panel scan channel.

When temperature compensation is turned on in the scan mode, under the R and R-T test functions, **CH01 is the temperature test channel whose measurement results are used to compensate for resistance measurements, and the rest of the channels are resistance test channels.** Under the T-test function, all are temperature tests.

6) Comparison results show that

Corresponding comparison result output for each test channel. When the comparison is turned off, NC is displayed, and the comparison mode of the boundary is set through Parameter Setting → Measurement Setting → Boundary Setting, and the comparison boundary is set individually for each channel. Higher than the limit displays red display HI, lower than the limit red display LO, qualified comparison green display GD.

2.4 Main Menu Buttons

2.4.1 Measurement Display MEAS

The measurement display is divided into stand-alone mode (Alone) and scanning mode (Scan). The interface displays are shown in Figure 2-3 and Figure 2-4 respectively.

2.4.2 Parameter Setting SETUP

Used to access the parameter settings. This page is shown in Figure 2-5.

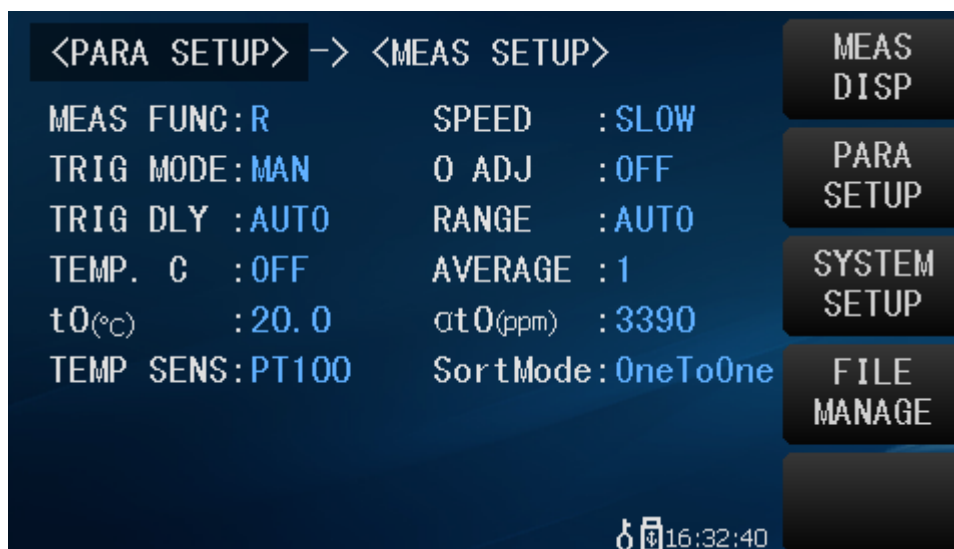

Figure 2-5 Parameter Setting Interface

2.4.3 System Settings SYSTEM

Used to access system settings. This page is shown in Figure 2-6.



Figure 2-6 System Setting Interface

2.5 Basic Operation

The basic operation of the TH2518 keypad is described below:

- Use the menu buttons (**MEAS**, **SYSTEM**, **SETUP**, **FILE**) and the softkey touch area to select the interface to be displayed.
- Use (**←**, **↑**, **→**, **↓**) to move the cursor to the field you want to set. When the cursor moves to a field, the field will change to the cursor color representation.
- The software function for which the cursor is currently active is displayed in the "softkey area". Select and press the desired softkey.

The TH2518 touch page is easier to operate, just press the corresponding function of the page with your finger and it will work accordingly.

It is worth noting that never use sharp objects and fingernail tips to touch the page, which may cause damage to the touch page, the damage caused by this, our company will not be responsible.

2.6 Power On

Plug in the three-wire power plug to ensure that the power ground is reliably connected. Press the power switch at the lower left corner of the front panel of the instrument, the instrument turns on and the power-on page is displayed.

Figure 2-7 shows the power-up page of the TH2518. The power-up page includes some product information such as Tonghui's trademark, instrument model number, and version number.



Figure 2-7 TH2518 power-up page

If the user has enabled the password protection function, the instrument will ask for the power-on password. According to the page display, enter the power-on password and press **ENTER** to enter the main menu page.

Note: This series of products set the factory power-on password, the **factory password is 2518**, the use of units can be in the process of use, according to their own needs, reset the power-on password. For details, please refer to <System Settings> page for the **password** item.

Chapter 3 Basic Operation

3.1 Measurement Display

This interface is used to display measurement results and can be accessed through the software and the **MEAS** key on the front panel. Depending on the test mode, the display page is divided into two types as described below:

3.1.1 Stand-alone Mode

Select Alone via **SYSTEM** key → Measurement mode.

When the instrument is in stand-alone mode (Alone), the <Measurement Display> page will be displayed on the page using the touch page or by pressing the **MEAS menu** key. This is shown in Figure 3-1:



Figure 3-1 Alone Mode Measurement Display Interface

As shown in the figure, you can set the relevant test parameters and the display of measurement results in this interface, as detailed below:

3.1.1.1 Test Parameter

The TH2518 can measure the following parameters:

- R (resistance)
- R-T (resistance and temperature)
- T (temperature)

Measurement function setting procedure:

When the measurement parameter area is selected using a key or touch, the right-hand side of the page displays

- R
- R-T (TH2518A does not have this feature)
- T (TH2518A does not have this feature)

3.1.1.2 Range

1) TH2518 and TH2518A have 7 DC resistance test ranges: 200mΩ, 2Ω, 20Ω, 200Ω, 2kΩ, 20kΩ, 200kΩ.

2) There are three types of TH2518 temperature tests:

Test range of PT100 temperature: -50°C~250°C.

Analog temperature test range: 0~2V

Testing range of PT500 temperature: -50°C~250°C.

3) Test range setting procedure:

Touch the range area, the softkey area will display the following menu, touch the key to make a selection of the test range.

■ **AUTO**

Used to set the range to automatic mode.

■ **HOLD**

Used to switch the range from AUTO mode to HOLD mode. When the range is set to HOLD mode, it will lock the test range, at which time the range can be set by the up and down arrows in the software area. The current test range is shown in Figure 3-2. The current test range will be displayed in the range area of the page.

■ **NOMINAL**

This is called "Nominal range". (Alone) mode, select NOMINAL range measurement, i.e., the range where the <Nominal> value in <Parameter Setting>→<Boundary Setting> is located. For example, the nominal value is 100Ω, as shown in Figure 3-2, belonging to the 200Ω range, which is equivalent to the measurement with 200Ω range at this time. Click HOLD range again, at this time the current test range will be displayed in the range area of the page with the range to which the nominal value belongs.

The NOMINAL "Nominal value range" is mainly used in the scanning mode, (Scan) mode, where you can set your own nominal value for each channel individually. In this case, the NOMINAL range is used for scanning measurements, and you can set your own range for each channel. When scanning, compared with the AUTO range, there is no need for range jumping, which is equivalent to fixing the range for each channel, so that scanning results can be obtained more quickly.

■ **↑(+)**

Used to select the range upwards.

■ **↓(-)**

Used to select the range downwards.

4) TH2518 Measurement Range Table

Range	Measurement Range	Resolution	Magnifying Power	Amps
200mΩ	10μΩ~210mΩ	10μΩ	100 times	100mA
2Ω	190mΩ~2.1Ω	100μΩ	10 times	100mA
20Ω	1.9Ω~21Ω	1mΩ	10 times	10mA
200Ω	19Ω~210Ω	10mΩ	10 times	1mA
2kΩ	190Ω~2.1kΩ	100mΩ	10 times	100μA
20kΩ	1.9kΩ~21kΩ	1Ω	1x	100μA
200kΩ	19kΩ~200kΩ	10Ω	1x	10μA

Figure 3-2 TH2518 Measurement Range Table

3.1.1.3 Measuring Cell

The TH2518 supports up to 6 measurement units. In stand-alone (Alone) mode, you can choose to use one of the six test units for stand-alone testing.

When the measurement parameter is "R" or "T", "R" or "T" is input from the front panel to measure resistance or temperature. or "T" is input from the front panel to measure resistance or temperature, you can select Unit 1 to Unit 6 units for measurement.

When the measurement parameter is "R-T", R measures the resistance value from the front panel input (FRONT INPUT), and T measures the temperature from channel 1 "CH1" on the rear panel.

3.1.1.4 Measurement Speed

TH2518 resistance test result data is displayed as 5 digits in decimal floating mode. Temperature test results are displayed in 4 digits with one digit after the decimal point.

Touch the speed area and the following menu will be displayed in the soft key area. With the speed setting cursor selected, select the above soft key to modify the setting.

FAST

MED

SLOW

3.1.1.5 Temperature Compensation

Touching **Temperature Compensation** displays the following menu.

■ ON

Indicates temperature compensation.

■ OFF

Indicates no temperature compensation.

3.1.1.6 Comparison

Touch **Compare** and the following menu is displayed.

■ ON

Indicates that the compare function is turned on.

■ OFF

Indicates that the comparison function is off.

3.1.1.7 Artifact

Touch the **tool** area, and the softkey area displays the following menu:



- **Demonstrate**

Switch for measured value display, ON for displaying the measured value, OFF for not displaying.

- **0 ADJ**

Indicates whether the base data is valid or not, ON indicates that the base data is valid, and OFF indicates that the base data is invalid.

- **0 ADJ**

Perform a short-circuit clearing operation, this process must ensure that the test end should have a good connection, otherwise it will bring unnecessary errors to the later measurement results.

The test fixture should be properly shorted, and the correct shorting method is shown below:

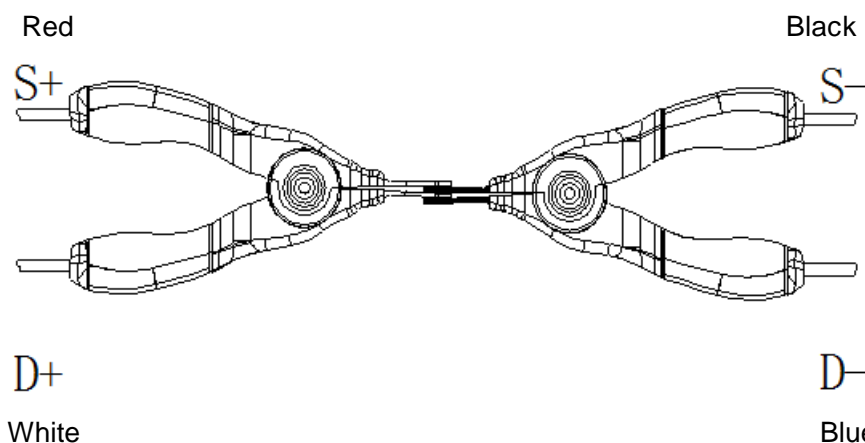

Figure 3-3 Alone Short Circuit Calibration Test Fixture Connection Methods

Zeroing Threshold: When the zeroing operation is executed, if the zeroing base exceeds the set threshold, the corresponding zeroing operation will be invalid. Threshold value for each function: ① Resistance R: 20% of the current range. ② Temperature T: when the sensor is PT100, the threshold is 20Ω; when the sensor is PT500, the threshold is 100Ω; when the sensor is Analog, the threshold is 0.4V.

Invalid zeroing situation: ① When the power is turned off and on again, the zeroing base is not saved. When switching between Alone and Scan, it is necessary to perform zeroing again. When the test unit is switched, it is necessary to perform zeroing again.

■ Save data

Pressing this touch key changes this key to **SAVE DATA ON**, indicating that the current test results are continuously saved to a .CSV file on a USB flash drive for each measurement, or not saved if the user has not previously inserted a USB flash drive. Pressing **Save Data ON** again changes it back to **Save Data OFF**, which stops saving data. At this time. Every time you switch OFF and ON, a new .CSV file is created on the USB flash drive. This file can be opened on a computer to analyze the measured data.

See section 3.4.1 for the data saving format.

Note: Press **Save Data OFF** to start saving data and be sure to press **Save Data ON** at the end to stop saving data, otherwise data will be lost.

3.1.2 Scanning Mode

Scan is selected via **SYSTEM** key → **Measurement mode**.

When the instrument is in Scan mode (Scan), use the touch page or press the **MEAS** menu key to enter the <Measurement Display> page, as shown in Figure 3-4:



Figure 3-4 Scan Mode Measurement Display Interface

Each plug-in board supports the user to configure up to 15-channel scanning, the combination of measurement methods between the channels to support the user to freely program up to 90-channel resistance/temperature scanning measurements, each measurement can be individually designed to sort the comparison of the boundary as well as the output of the comparison of the sorting signals (the rear layout of the six test units is shown in Figure 2-2).

The measurement display page has a total of 6 pages, each displaying the scanning test results of 16.

The options in <Tools> are the same as in standalone mode. Except that the 0 ADJ targeted is for 90 channels. The user can set up test units and test channels for up to 90 channels. 0 ADJ is performed after shorting the scan input connector at the rear panel.

Up to 90 channels of resistance/temperature scanning test terminals, and each channel test terminal can be programmed, greatly improving the efficiency and flexibility of product scanning test.

This product can integrate up to 6 independent test units, the scanning test between test units can be synchronized, in order to ensure the accuracy of stand-alone testing at the same time, the test speed will be increased by 6 times, so that the highest test speed up to 600 times / sec.

Each test unit is pluggable, allowing customers to rationalize cost savings based on actual applications.

Compatible with stand-alone test functions, flexible switching between temperature measurement and resistance measurement functions, enabling 1 machine for multiple uses.

3.2 Measurement Settings

Use the touch page or press the **SETUP** menu key to enter the <Parameter Setup> → <Measurement Setup> page, as shown in Figure 3-5:

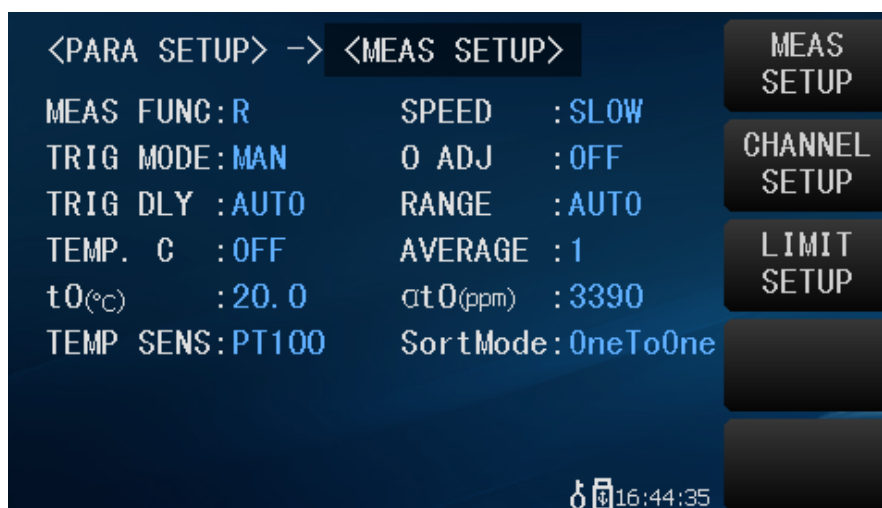

Figure 3-5 Parameter Setting Interface

3.2.1 Measured Parameter

When the measurement parameter area is selected using a key or touch, the right-hand side of the page displays

R

R-T (TH2518A does not have this feature)

T (TH2518A does not have this feature)

3.2.2 Measurement Speed

TH2518 resistance test result data is displayed as 5 digits in decimal floating mode. Temperature test results are displayed in 4 digits with one digit after the decimal point.

Touch the speed area and the following menu will be displayed in the soft key area. With the speed setting cursor selected, select the above soft key to modify the setting.

FAST

MED

SLOW

3.2.3 Trigger Mode

Touch **Trigger** to display the following menu.

■ INT

Instrument internally triggered automatic measurement mode

■ MAN

Front panel **START** key triggers manual measurement mode

■ **EXT**

External trigger measurement mode

■ **BUS**

Bus-triggered measurement mode

3.2.4 0 ADJ

Indicates whether the base data is valid or not, ON indicates that the base data is valid, OFF indicates that the base data is invalid.

3.2.5 Measurement Delay

Touch **Measurement delay** to display the following menu.

automation

Internal automatic time delay, default delay 5ms

manually operated

Display the value 3ms, press this touch key, the page pops up the numeric keypad, manually input the measurement delay time, its input range: 0ms~9999ms.

3.2.6 Range (R)

See section 3.1.1.2.

3.2.7 Temperature Compensation

When temperature compensation is turned on, you need to connect the temperature probe to the diagram below:

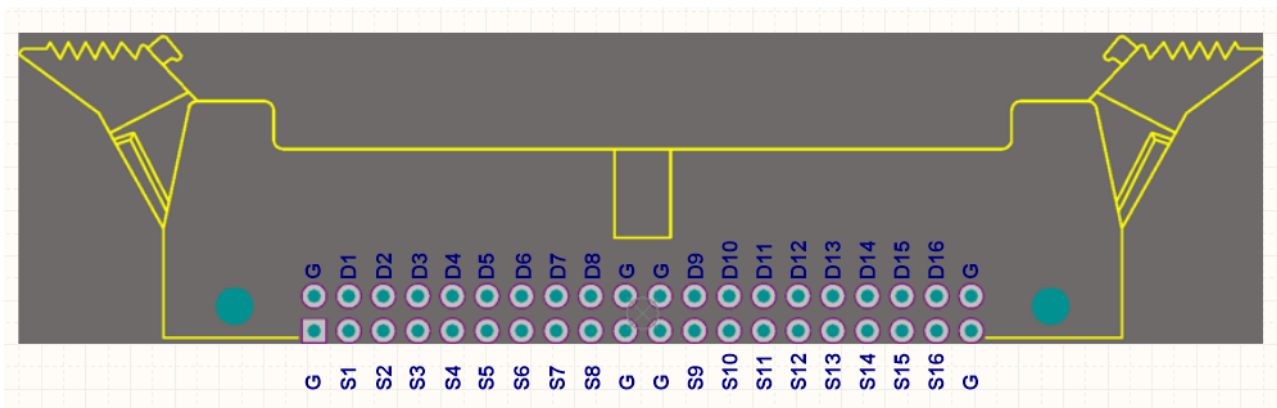

Measurement of temperature channel is always CH01, if the test unit of CH01 is U1, the high end of the test is T01, the low end of the test is T02, the temperature probe is connected to the first plug board, one end of the temperature probe is connected to S1, D1, and the other end is connected to S2, D2; if the test unit of CH01 is U3, the high end of the test is T09, and the low end of the test is T10, then the temperature probe is connected to the third plug board, one end of the temperature probe is connected to S9, D9, and the other end is connected to S10, D10. If the test unit of CH01 is U3, the high end of the test is T09 and the low end of the test is T10, the temperature probe is connected to the third plug board, and one end of the temperature probe is connected to S9 and D9, and the other end to S10 and D10.

3.2.8 Average

Pressing this touch key, the page pops up the numeric keypad to set the average number of times of its measurement value, the setting range is 1~255. the larger the number set, the more accurate the value is, but the longer the time it takes to measure.

3.2.9 Transducers

Touching **the sensor** displays the following menu.

- PT100
- PT500

This function refers to the conversion of the resistance value obtained from testing at the current ambient temperature to the resistance value at the user-set temperature.

Calculation formula: $R_t = R_{t0} * \{1 + at0 * (t - t0)\}$

t Indicates the current ambient temperature value

R_t Indicates the resistance value measured at t temperature

R_{t0} Indicates the resistance value at the set temperature

$t0$ Indicates the set temperature value, which is set in the <Measurement Settings> page.

$at0$ Indicates the temperature coefficient of the material, which is set in the <Measurement Settings> page.

For example, if the resistance measured at 20 °C is 100 Ω (assuming a material factor of 3930 ppm), then the value of the resistance at 10 °C is:

$$R_{t0} = \frac{R_t}{1 + at0 * (t - t0)} = \frac{100}{1 + (3930 \times 10^{-6}) \times (20 - 10)} = 96.22\Omega$$

Before measurement, there should be enough time for the instrument and probe to warm up for a while, usually about half an hour, the temperature sensor should be as close as possible to the measured component, but do not contact it, and wait for the measurement of the displayed value to stabilize before reading.

- **AnLG_In**

By pressing the touch key and selecting **AnLG_In**, the input type for temperature is analog input and the range of input voltage is 0~2 V. The model diagram for this analog input is shown below:

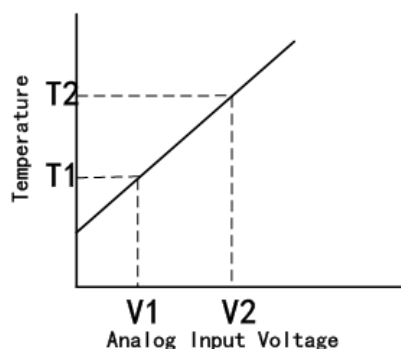

The formula for this analog input is:

$$T = \frac{T2 - T1}{V2 - V1} \times \text{InputVoltage} + \frac{T1 \times V2 - T2 \times V1}{V2 - V1}$$

$V1$, $T1$, $V2$, and $T2$ are set in the <Measurement Settings> page, with ranges of 0.00V to 2.00V for $V1$ and $V2$, and ranges of -99.9 °C to 999.9 °C for $T1$ and $T2$.

3.2.10 Sorting Mode

Touch **Sorting Mode** and the following menu is displayed.

- OneToOne

See section 8.3.

- Shift

See section 8.3.

3.3 Boundary Settings

3.3.1 Alone Mode

Pressing **SETUP**→<Measurement Setup>→<Boundary Setup> will enter the Alone mode <Boundary Setup> page. As shown in Figure 3-6:

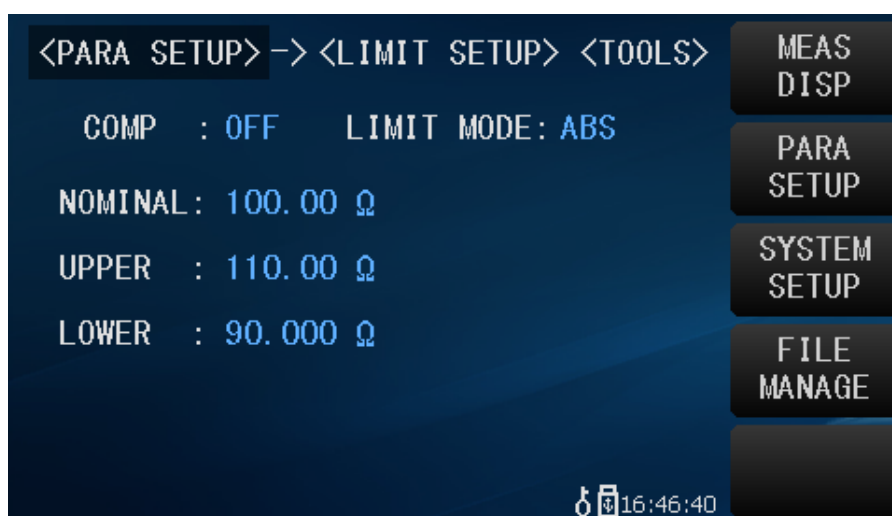

Figure 3-6 Alone Mode Boundary Settings

3.3.1.1 Comparative State

Touch **Compare** and the following menu is displayed.

- ON

Indicates that the compare function is turned on.

- OFF

Disables the comparison function.

3.3.1.2 Boundary Model

By touching the **Compare Mode** operation, the following menu is displayed.

- ABS (absolute value mode)

Selecting this mode, only the upper limit and lower limit values are set, the nominal setting is useless, the measured value will be compared directly with the set upper and lower limit values to determine whether it is higher (HI) or lower (LO), and if it is within the range of the set value, it will be a qualified product (GD). **The set upper limit value must be greater than or equal to the lower limit value.**

- Perc (percentage deviation)

Select this mode to set both the nominal value and the upper and lower limits. If the set nominal value is 1Ω , the upper limit is 5%, and the lower limit is -3%, then $1 \times (1 + \text{upper limit})$ is the highest and $1 \times (1 + \text{lower limit})$ is the lowest, and it is judged whether it is higher (HI) or lower (LO), and if it is within the range of the set value, then it is a conformity product (GD). **This nominal value is the reference value for the deviation display mode.**

- AbsDev (absolute deviation mode)

Select this mode, the nominal value and upper and lower limits are set, if the set nominal value of 10Ω , the upper limit is 5Ω , the lower limit is -3Ω , then the nominal value (10Ω) + upper limit (5Ω) is the highest, the nominal value (10Ω) + lower limit (-3Ω) is the lowest, to determine whether it is higher than (HI), or lower than (LO), if in the range of the set value for the qualified product (GD).

3.3.1.3 Artifact

Press Page Tools to display the following menu.

- Comparative hearing

The ON buzzer turns on.

OFF The buzzer sounds off.

- signaling mode

The buzzer sounds when the audible mode is NG (measured value does not match the set value).

The buzzer sounds when the audible mode is GD (measured value matches the set value).

3.3.2 Scan Mode

When the measurement mode is Scan, press SETUP → <Parameter Setting> → <Boundary Setting>, it will enter the Scan mode <Boundary Setting> page. As shown in Figure 3-7:

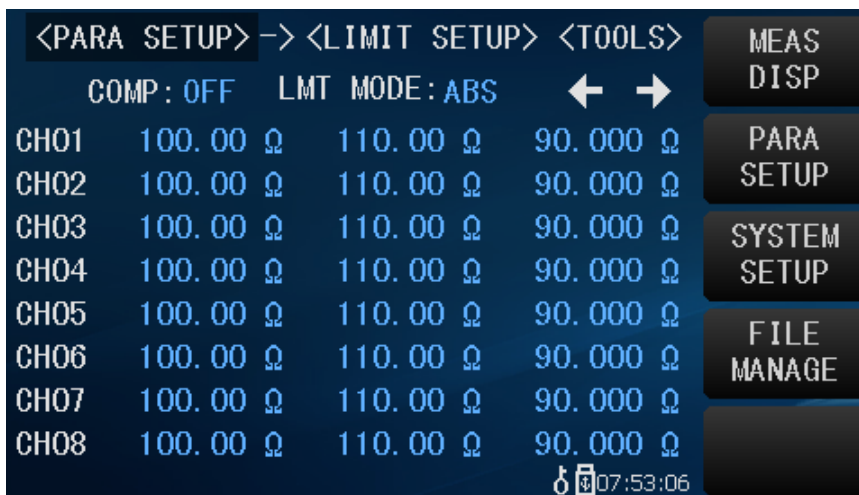

Figure 3-7 Scan Mode Boundary Settings

Touch boundary modes, there are three boundary modes Perc (percentage deviation mode), AbsDev (absolute value deviation mode), and ABS (absolute value mode).

The three boundary settings and tool options are described as in Alone Boundary Settings.

Note: In Scan Boundary Setting Mode, there are 12 pages with 8 channels on each page that can be set independently for nominal values and upper and lower limits. The left and right arrows can be used to flip through the pages to set the boundaries for each channel. One column after the channel number is the nominal value option; the next column is the upper

limit, and the rightmost column is the lower limit. Touch the corresponding change area and enter a numeric key to make the change.

3.4 Channel Settings (Scan mode)

When the measurement mode is Scan, press SETUP→<Parameter Setting>→<Channel Setting>, it will enter the Scan mode <Channel Setting> page. As shown in Figure 3-8:

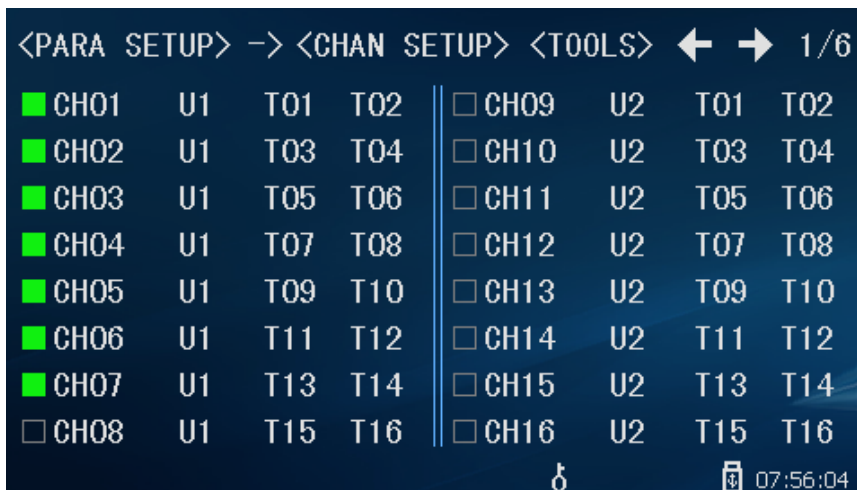

Figure 3-8 Scan Mode Channel Settings

Channel display settings, the instrument group can be configured into more than 90-way scanning test. 6 pages, 16 scanning channel settings per page, page turn by left and right arrows.

■ Channel ON/OFF

Each channel can be freely selected as ON or OFF. e.g. touch the CH01 area and select OFF in the right softkey area, the small box in front of CH01 will turn white, which means this CH01 channel is off; select ON, the corresponding small box in front of CH02 will turn green.

■ Selection of test units

Scanning channel settings, up to 90 measurement scanning channels can be configured to support a maximum of 6 plug-in boards, each plug-in board can be connected to a maximum of 15 parts under test each channel user can freely configure the test scanning unit. For example, by touching the U1 area of the CH01, there are two test units available in the right softkey area, unit 1 to unit 6.

■ Testing high-end options

The first column to the right of each test cell defaults to the selection of the high-end channel. For example, T01 means that both the driver (D+) and the sample (S+) of the high end of CH01 are selected. Similarly, T15 means that both the drive side (D+) and the sample side (S+) of the high end of CH15 have been selected.

■ Testing the low end of the options

The second column to the right of each test cell defaults to the selection of the low-end channel. For example, T02 means that both the driver (D-) and the sampler (S-) of the low end of CH02 are selected. Similarly, T16 means that both the driver (D-) and the sampler (S-) of the low end of CH16 are selected.

3.5 Junction Box and Scanning

3.5.1 Junction Box (accessory)

Inside each junction box are four terminal blocks, each with four user-selectable channels T01-T16 that can be freely combined. Theoretically, any channel can be combined with any of the other 15 channels in addition to itself.

The layout of the terminal block is shown in Figure 3-9:

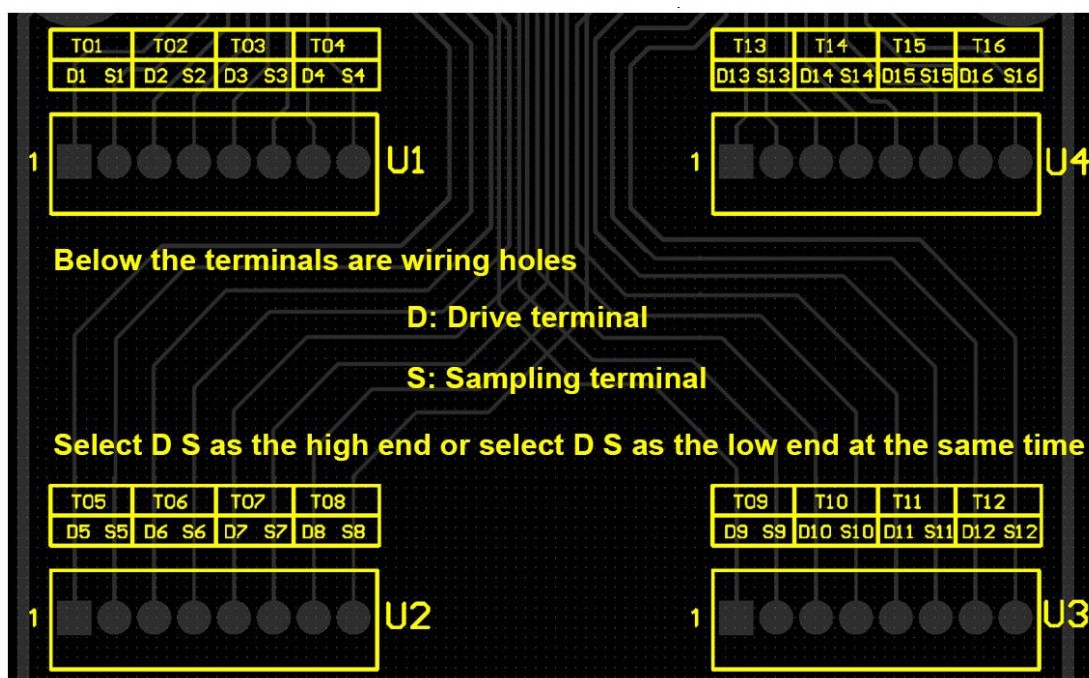

Figure 3-9 Terminal Block Layout

When wiring the terminal block, note that the wiring is based on the scanning channel settings in Scanning <Channel Settings>, and make sure that there is a one-to-one correspondence between the wiring and the channel settings.

Users do not need a scanner box, make your own scanner, use wire diameter: 18-26AWG, stripped wire length: 4.5mm, refer to Chapter 8 on "Scanning Plug-in Board Pin Interface Description".

3.5.2 Scanning

15 channels/card, up to 6 cards and 90 channels can be inserted. The channels within the card are scanning test, and the test cards are synchronized with each other. The selection between channels can be freely set by the user. The scanning results of 90 channels are displayed on the page at the same time, and it supports turning pages to view the scanning results.

After the user has freely set up the scanning channels, regarding the scanning work: ① Firstly, group the channels according to the test units (i.e. U1~U6). ② The channels of the same test unit (i.e. CHxx) are measured in order from smallest to largest. ③ The scanning is done in parallel between test units, and the scanning time is determined by the test unit with the highest number of channel settings.

Chapter 4 System Settings and File Management

4.1 System settings

Press the key **SYSTEM** or press System Setup in the main menu display area of the touch page to enter the <System Setup> interface. As shown in Figure 4-1:



Figure 4-1 System Setup Interface 1

This page is used to set the measurement mode, touch tone, system language, password setting, bus mode, baud rate, power supply frequency, Handler power supply, and shift output.

The next page is used for the settings of FetcAuto, 232 Protocol, HdI Time and other functions.

4.1.1 Measurement Mode

Used to select the measurement mode of the instrument.

Procedure for setting the measurement mode:

Press the **Measurement Mode** touch key and the page soft key area is displayed:

- **Scan**

Set to scan mode.

- **Alone**

Set to stand-alone mode.

Press the corresponding touch key in the softkey area to select the corresponding function.

4.1.2 Language

The language mode of the operator interface used to control the instrument.

Language setting procedure:

Press the **language** touch key. The page softkey area is displayed:

- **English (language)**

Used to select the English operation interface.

- Chinese

Used to select the Chinese operation interface.

Press the corresponding softkey in the softkey area to select the corresponding function.

4.1.3 Password

Password-protected mode for controlling the instrument.

Password setting procedure:

Press the mnemonic touch key and the page soft key area is displayed:

- OFF

Used to turn off the password protection function. The user must enter the correct password before the password protection function can be turned off.

- locking system

Used to activate password protection functions, including file protection and power-on passwords.

- Locking files

Used for user's file protection.

- modifications

Used to change the password.

The operation is as follows, press the Modify touch key, the page pops up the numeric keypad, enter the original passphrase, and press ENTER to confirm. The page pops up the numeric keypad again, enter the new password, and press ENTER to confirm. The page pops up the numeric keyboard again, enter the new password again, and press ENTER to confirm the new password. The password modification is completed.

Note: The default power-on password is "2518" and the upgrade password is "25182014".

4.1.4 Touch Tone

A tone used to control the user's touch page.

Procedure for setting the touch tone:

Press the touch tone touch key. The page soft key area is displayed:

- ON

Used to turn on the touchpage tone.

- OFF

Used to turn off the touch page tone.

Press the corresponding touch key in the softkey area to select the corresponding function.

4.1.5 Bus Mode

The bus mode is used to select the communication interface of the instrument.

Bus mode setting procedure:

Press the **Bus Mode** touch key and the following softkeys are displayed in the softkey area of the page:

- **RS232C**

Pressing the **RS232C** touch key selects the RS232C interface.

- **LAN**

Pressing the **LAN** touch key selects the LAN interface.

- **USBTMC**

Pressing the **USBTMC** touch key selects the USBTMC interface. Communication is via the USB port (USB DEVICE) on the rear panel of the instrument.

- **USBVCOM**

Pressing the **USBVCOM** touch key selects the USBVCOM interface. Virtual serial port via USB port (USB DEVICE) on the rear panel of the instrument for communication.

Note: See chapter VI for details

4.1.6 Baud Rate

This option is used to set the baud rate for RS232 communication. Pressing this touch key displays the six selectable baud rates in the soft key area of the page:

9600
19200
28800
38400
96000
115200

4.1.7 Power Frequency

According to the different power supply frequency for the corresponding selection, the main role is to eliminate the power supply noise on the measurement instrument interference, TH2518 provides two kinds of power supply frequency: **50Hz** and **60Hz**.

4.1.8 Handler Power Supply

Press the **Hdl Power** touch key. The page soft key area is displayed:

- **externally**

Pressing the external touch key selects the external power supply Handler.

- **inside (part, section)**

Pressing the internal touch key selects the internal power supply Handler.

4.1.9 Shift Output

Combined with the three analog serial signals SER, RCK and SCLK of the Handler interface, the 90-channel comparison result signals are shifted to output. **Refer to the Handler Interface section for specific shift timing and circuitry.**

4.1.10 232 Address

When the communication protocol of RS232C is MODBUS, the **232 address** indicates the sending address of MODBUS protocol.

4.1.11 Record-keeping

Touching **Bottom Number Save** displays the following menu.

◆ ON

Indicates that the bottom number saving function is turned on. When this function is turned on, it is necessary to execute 0 ADJ under **<Measurement Display>** page tool.

The next time you turn on the power, the bottom number will remain the same as the last 0 ADJ.

◆ OFF

Indicates that the bottom number saving function is off.

4.1.12 Base-to-valve Ratio

Pressing this button brings up the numeric keypad on the page, and the range of setting is 1~100. If the bottom number is within the range of the current range value multiplied by the bottom number threshold ratio, it can successfully execute the 0 ADJ under the tool on the **<Measurement Display>** page, and if it is outside of the range, it will prompt "Failed to execute the bottom number clearing operation". If this message appears, you can increase the bottom threshold ratio to successfully execute the bottom zero operation.

4.1.13 Time and Date Setting

Used to set the correct time for the local time zone.

E.g., February 08, 2013 9:21:19 AM displays the format: 13-02-08 09:21:19

Press the time area of the touch page that needs to be modified and the soft key area is displayed:



By pressing this touch key, the instrument rapidly increases the time upwards in steps of 5.



By pressing this touch key, the instrument increases the time upwards in steps of 1.



By pressing this touch key, the instrument decreases the time downward in steps of 1.



By pressing this touch key, the instrument rapidly decreases the time downward in steps of 5.



Pressing this touch key moves the cursor under the time to the left.



Pressing this touch key moves the cursor under the time to the right.

4.1.14 Artifact

■ system reset

This is equivalent to a reboot operation of the instrument.

■ default setting

Reset the instrument's full parameter (including test parameters and system parameters) settings to the initial state.

■ network setup

Network control of the instrument for LAN port operation control.

The Network Setup page is shown in Figure 4-2:

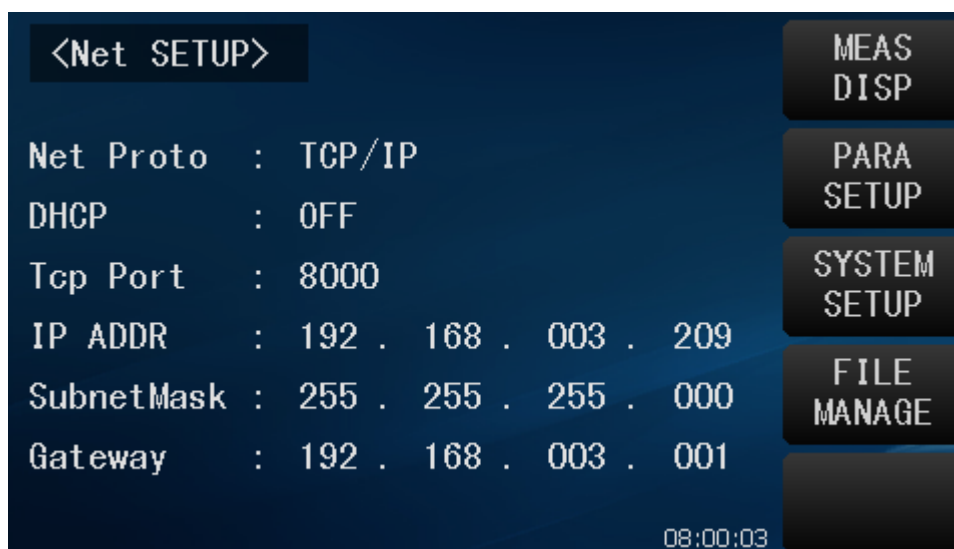

Figure 4-2 Network Setting Interface

4.1.15 232 Protocol

Press this touch key to select whether the communication protocol of RS232C is SCPI or MODBUS.

Note: Only RS232C communication can select SCPI or MODBUS. LAN, USBTMC, and USB VCOM communication are all SCPI protocols.

4.1.16 FetcAuto

Press this touch key to select whether the communication measurement data is automatically returned to the host computer.

4.1.17 Hdl Time

Setting this parameter delays the duration of the Handler interface binning signal and the Handler binning board binning signal.

4.2 Document management

The TH2518 series instruments can store the parameters set by the user in the form of a file in the internal non-volatile memory of the instrument. When you want to use the same settings next time, you do not need to reset these parameters, just load the corresponding file, you can get the last set parameters.

This section provides information about the TH2518's store/recall function.

Symbol Description:

E: is the abbreviation of External, which stands for external memory, e.g., USB flash drive.

I: is the abbreviation of Internal, which stands for internal memory, i.e., the internal Flash of the TH2518.

4.2.1 Introduction to Store/Recall Functions

The store/recall function allows the user to both save and recall measured results and instrument configuration information to and from the TH2518's internal FLASH or USB flash drive.

The following table describes the available preservation methods and their uses:

Preservation Methods		Callable	Use
Typology	File Format		
Configuration saving (internal FLASH)	*.STA	Yes	Saves the configuration state of the instrument to the internal Flash.
Configuration saving (external USB flash drive)	*.STA	Yes	Saves the configuration status of the instrument to a USB flash drive.
Data saving (external USB flash drive)	*.CSV	No	Saves the measurement results to a USB flash drive.
Page save (external USB flash drive)	*.gif	No	Saves a snapshot of the instrument's page to a USB flash drive.

Table 4-1 Preservation Methods and Their Uses

4.2.2 Folder/file Structure on USB Flash Drive

When saving the information to the USB flash drive, it is recommended that users use the files and folders pre-created on the memory, as shown in Table 4-2. If the user wants to save the configuration information file in his/her own newly created folder, he/she needs to enter the folder first and then perform the related file operations.

File	Maximum Number of Documents	Description
CSV	999	Includes measurement results such as *.CSV files, see Chapter 7, SCPI→FETCH Command set, for details on the data storage format.
STA	999	Includes instrument configuration information such as *.STA files.
IMAGE	20	Includes page snapshots such as *.gif files.

Table 4-2 Folders in the USB flash drive

Note: CSV, STA folders can be automatically generated when the instrument is connected to the USB flash drive.

The folder/file structure on the USB flash drive is shown in Figure 4-3:

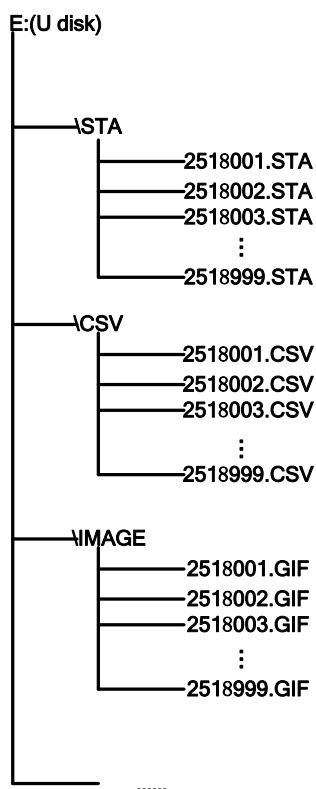

Figure 4-3 File structure in a USB flash drive

The following points should be noted when using a USB flash drive on the TH2518.

- 1) Use a USB flash drive with a USB 2.0 interface.
- 2) The file system of the USB flash drive used should be FAT16 or FAT32 and formatted using the FAT16 or FAT32 standard; for USB flash drives exceeding 512M, it is recommended that the user use the FAT32 standard for formatting.
- 3) Before connecting a USB memory stick to the TH2518, users are advised to back up the data saved on the USB memory stick. Tonghui is not responsible for the loss of data in the USB storage device when the USB storage device is used with the TH2518.
- 4) For you to efficiently save instrument data to the USB flash drive, it is recommended that there are not too many files or folders on the USB flash drive.

4.2.3 File Management Procedure

Pressing the **FILE** button on the front panel of the instrument, or touching **File Management** in the right softkey area of any interface of the instrument will enter the File Management page.

Pressing the **internal file** and **external file** touch keys in the page softkey area will display the files saved in the internal FLASH or the files saved in the external USB flash drive on the page, respectively.

The Internal Files page and the External Files page display information about four files per page, containing the file name and when the file was saved.

Internal and external file operations are similar; the following internal file operations as an example, to describe the specific steps of file operations.

The following is the method for each operation of the file:

Touch the name of the file to be edited (if the file to be edited does not exist on the current page, you can touch the left and right arrows to switch the file page, and then select the desired file), and then the softkey area of the page is displayed as follows:

- **Load**

Press this touch key, if the file name at the corresponding place of the cursor is not empty, the page soft key area displays **Yes** and **No**. Select **Yes** to call up the settings in the file; select **No** to cancel the current operation.

- **Save**

Press this touch key, then the page soft key area displays **Yes** and **No**. If you select **No**, the current save file operation will be canceled; if you select **Yes**, the alphabetic keyboard will be popped up, and after inputting the file name, press **ENTER** to confirm, then the instrument will save the current interface parameter settings into the file. (Note: If a file already exists in the corresponding file serial number position when saving the file, the execution of the save operation will overwrite the original file.)

- **Delete**

Touch **Delete**, select **Yes**, and the instrument will delete the file where the cursor is located.

- **Copy to E:**

Touch "Copy to E:", the instrument will copy the file at the cursor and the selected file to the USB flash disk.

- **Option**

Touch "Select", the file at the cursor will be selected. TH2518 supports copying multiple files to USB flash disk at the same time.

Touch **Select** again and the selected file will be unselected.

4.2.4 Storage of Measurement Results



On the <Measurement Display> page, touch **Tools**, and then touch the softkey area menu **Save Data OFF**, and the instrument saves the measurement results to a USB flash drive. Touch **Save Data ON**, the instrument stops saving the measurement results.

Chapter 5 Performance Indicators

5.1 Measurement Function

5.1.1 Measurement Parameters and Symbols

R: Resistance

T: Temperature

5.1.2 Measurement Mode

Alone: stand-alone mode

Scan: Scan mode

5.1.3 Measurement Combinations

Measurement parameter combinations

TH2518: R, R-T, T

TH2518A: R

5.1.4 Range

Measurement modes: AUTO, NOMINAL, HOLD, INCREASE, DECREASE.

5.1.5 Trig

Internal, manual, external, bus

Internal: Continuous measurement of the measured part and output display of the results

Manual: Pressing the panel **TRIGGER** key, the meter carries out a measurement and outputs the result for display and is normally in a waiting state.

External: After receiving the "start" signal from external sources through the Handler port on the rear panel, the unit performs a measurement and outputs the measurement result, and then enters the waiting state again.

Bus: Triggers instrument measurements via the communication interface.

5.1.6 Test End Approach

Alone measurements on the front panel and Scan measurements on the rear panel.

Four-end measurement is used:

DRIVE HI: Current driven high end

DRIVE LO: Current Drive Low

SENSE HI: Voltage Sampling High End

SENSE LO: Voltage sampling low side

5.1.7 Average

1-255 programmable: This number reflects the number of measurements taken from the measured resistance to the measured value display.

5.2 Test Signal

5.2.1 Ranging Current

TH2518: Range current: 10 μ A~100mA

TH2518A: Range current: 10 μ A~100mA

5.2.2 Open Output Voltage

Open circuit output voltage: 0.7V, 2.7V

5.2.3 Maximum Range of Measurement Display

Parameters	Measurement Display Range
R	10 μ Ω ~200k Ω
T	-99.9 $^{\circ}$ C~999.9 $^{\circ}$ C

5.3 Measurement Accuracy

Measurement accuracy consists of the basic measurement accuracy for basic temperature and humidity ambient conditions and a temperature correction factor for ambient conditions that exceed the basic temperature and humidity.

Always check the measurement accuracy of the instrument under the following conditions:

- 1) Power-on warm-up time: ≥ 30 minutes.
- 2) To test the cable for correct shorting, 0 ADJ is ON, press the touch key 0 ADJ for shorting calibration. Alone, test the cable for correct shorting method as shown in the figure below:

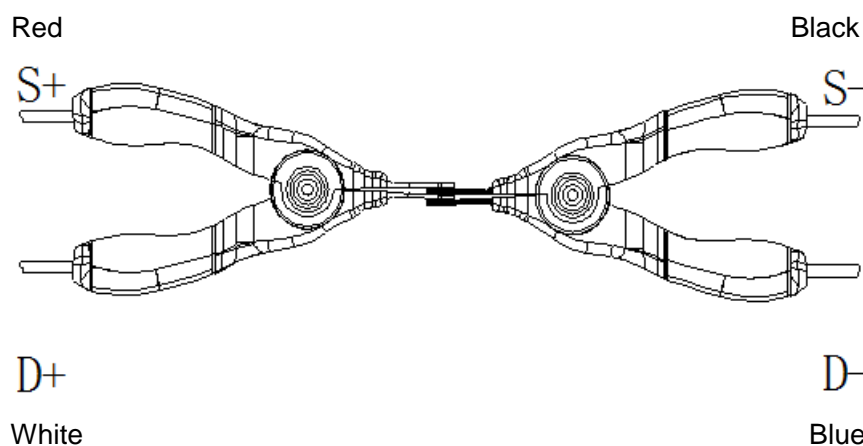

- 3) Basic temperature and humidity environmental conditions that ensure the basic measurement accuracy described below.

Temperature range: 23 $^{\circ}$ C \pm 5 $^{\circ}$ C

Relative humidity: $\leq 80\%$ RH

5.3.1 Resistance Scanning Measurement Accuracy

1 year of TH2518/TH2518A basic measurement accuracy (23 \pm 5 $^{\circ}$ C, $\leq 80\%$ RH)

Range	200m Ω	2 Ω	20 Ω	200 Ω	2k Ω	20k Ω	200k Ω
Amps	100mA	100mA	10mA	1mA	100 μ A	100 μ A	10 μ A

Open Circuit Voltage	0.7V	2.7V					
Resolution	10 $\mu\Omega$	100 $\mu\Omega$	1m Ω	10m Ω	100m Ω	1 Ω	10 Ω
Accuracy	0.05%+5						
Temperature Coefficient	300ppm	100ppm					

5.3.2 Temperature Measurement Accuracy (PT500, PT100)

$$\text{TH2518 Accuracy} = 0.3\% * \text{measured value} \pm 0.5 \text{ } ^\circ\text{C}$$

Temperature Range	-99.9~39.9 $^\circ\text{C}$	40.0~250.0 $^\circ\text{C}$
Resolution	0.1 $^\circ\text{C}$	0.1 $^\circ\text{C}$
Semi-annual Accuracy	$\pm 0.30\% \text{Rd} \pm 0.5 \text{ } ^\circ\text{C}$	$\pm 0.30\% \text{Rd} \pm 1.0 \text{ } ^\circ\text{C}$
One-year Accuracy	$\pm 0.45\% \text{Rd} \pm 0.8 \text{ } ^\circ\text{C}$	$\pm 0.45\% \text{Rd} \pm 1.5 \text{ } ^\circ\text{C}$

5.3.3 Temperature Measurement Accuracy (Analog Input)

Basic measurement accuracy of TH2518 series instruments for 1 year (23 \pm 5 $^\circ\text{C}$, \leq 80% RH)

Input Voltage Range	0~2V
Display Temperature Range	-99.9 $^\circ\text{C}$ ~999.9 $^\circ\text{C}$
Resolution	1mV
Accuracy	$\pm 1\% \text{Rd} \pm 3\text{mV}$

$$\text{Accuracy} = 1\% * (T_R - T_{0V}) + 0.3\% * (T_1 - T_{0V})$$

T_{1V} : Temperature at 1V input voltage.

T_{0V} : Temperature at 0V input voltage.

T_R : The current measured temperature.

Note: Rd is the displayed reading of the measuring instrument; Fs is the full scale range.

5.3.4 Temperature Correction Factor K

When the instrument is used in the following environmental conditions: 0 $^\circ\text{C}$ ~18 $^\circ\text{C}$, \leq 80%RH; 28 $^\circ\text{C}$ ~40 $^\circ\text{C}$, \leq 80%RH, the measurement accuracy of the instrument is the basic measurement accuracy value listed in 5.3.1-5.3.4 multiplied by the temperature correction coefficient K listed in the following table.

Temperature ($^\circ\text{C}$)	0~5	5~18	18~28	28~35	35~40
Temperature Correction Factor K	4	2	1	2	4

Chapter 6 Remote Control

6.1 RS232C Interface Description

Currently widely used serial communication standard is the RS-232 standard, can also be called asynchronous serial communication standard, RS for the "Recommended Standard" (Recommended Standard) of the English name of the abbreviation, 232 is the standard number, the standard is the American Electronics Industry Association (IEA) in 1969 officially announced the standard, which provides for one bit each time by a data line transmission.

As with most serial ports in the world, the instrument's serial interface is not strictly based on the RS-232 standard, but only a minimal subset is provided. The table below:

Code	Abridge	Connector Pin Number
Transmitted data	TXD	2
Received data	RXD	3
Grounding	GND	5

Table 6-1 Instrument RS232 Signal and Pin Comparison

The reason for this is that the operation of three wires is much cheaper than the operation of five or six, which is the biggest advantage of using serial port communication.

The instrument is connected to the computer as shown in Figure 6-2:

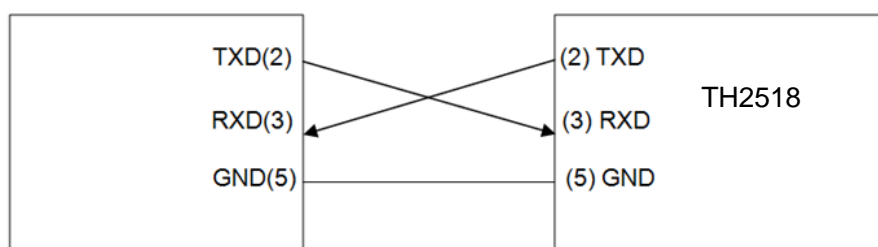

Figure 6-1 Schematic Diagram of Computer and Instrument Connection

As can be seen from Figure 6-1, the pin definitions of the instrument are different from those of the 9-pole connector serial interface pin definitions used by computers. Users can purchase the serial interface cable line between the computer and the Tonghui instrument from Changzhou Tonghui Electronics Co.

The RS232 interface baud rate can be selected from 9600 to 115200, no parity, 8 data bits, 1 stop bit.

Instrument commands are compliant with the SCPI standard. **When a command string is sent to the instrument, LF (hexadecimal: 0AH) is required to be sent as the ending character.** The maximum number of bytes of SCPI command string that the instrument can receive at one time is 2KB.

For the format of the result data sent from the instrument to the computer, see the Command Reference section for Commands.

6.2 LAN Remote Control System

On the <System Settings> page, touch **Tools**, and on the right softkey menu touch **Network Settings**, then you will enter the <Network Settings> page.

The TH2518 network parameters are set as shown below:

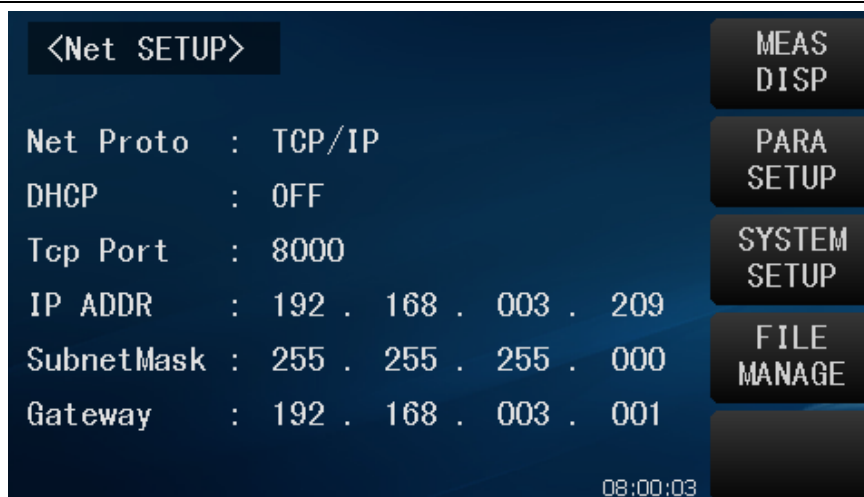

Figure 6-7 <Network Settings > Page

6.2.1 Network Protocol

Touch the **Network Protocol** area and the page softkey area is displayed:

- TCP/IP

TCP/IP is selected, and the instrument network uses the TCP/IP V4 communication protocol.

- LXI

LXI is selected, the instrument network uses the LXI protocol, and LabVIEW software is required for the host computer. The so-called LXI is a new instrument platform consisting of small and medium-sized bus modules based on industrial standards such as Ethernet technology.

6.2.2 DHCP

Touch the **DHCP** area and the page softkey area displays ON, OFF.

DHCP is an abbreviation for Dynamic Host Configuration Protocol. Steps to use DHCP:

- 1) Connect the instrument to the router with a network cable.
- 2) Touch the **DHCP** area and select ON.
- 3) Wait for the IP address to be automatically assigned. The instrument port number, IP address, subnet mask, and gateway are automatically assigned.

6.2.3 Port Number

Touch the **port number** area and the page will pop up the numeric keypad to enter the value. The port number range is 0 to 65535.

TCP and UDP port number assignments can be divided into 3 ranges:

- 1) Well-known port numbers (0~1023): managed by IANA and reserved for general-purpose TCP/IP applications.
- 2) Registered port number (1024~49151)
- 3) Dynamic or private port numbers (49152~65535): these ports are not managed by IANA and can be used by any organization.

The full port number assignment table is maintained by IANA and can be found at www.iana.org.

6.2.4 IP Address

Touch the corresponding area, the page pops up the numeric keypad to set the IP address, the setting range is 1~255.

6.2.5 Subnet Mask

Touch the corresponding area, the page pops up the numeric keypad, to the subnet mask setting, the setting range is 1~255. the default setting is 255.255.255.000.

6.2.6 Gateway

Touch the corresponding area, the page pops up the numeric keypad; to set the gateway, the setting range is 1~255. the fourth byte of the gateway is always 001. the third byte of the gateway and the third byte of the IP address are always the same.

6.3 USBTMC Remote Control System

The USB (Universal Serial Bus) remote control system controls devices via a USB interface. The connection is compliant with the USBTMC-USB488 and USB 2.0 protocols.

6.3.1 System Configuration

Connect the USB port on the rear panel of the TH2515 to the USB port on the host computer via the USB cable.

6.3.2 Installation of Drivers

The first time you connect the TH2515 to the computer with a USB cable, the computer will prompt "New Hardware Found" in the lower right corner of the desktop, followed by a pop-up dialog box requesting the installation of the driver. As shown in Figure 6-10 below:

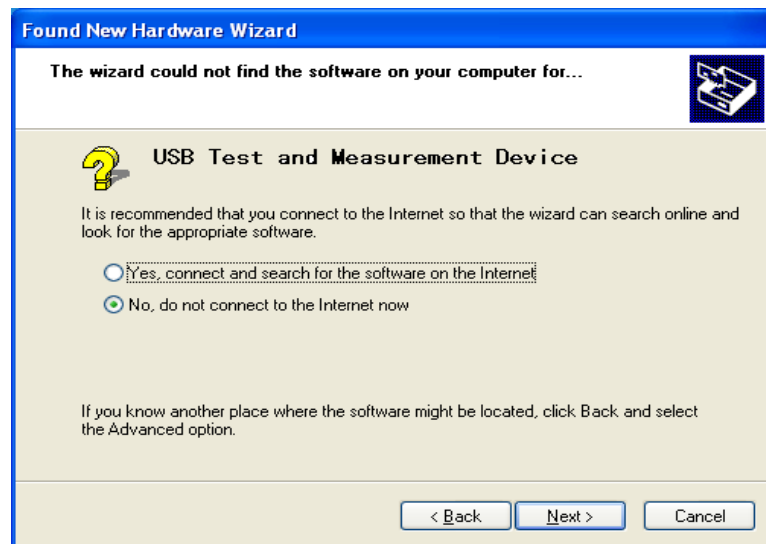

Figure 6-10 Installing the USB Driver Step 1

Click "Next", the dialog box shown in Figure 6-11 will pop up, select "Automatically install software (recommended)".



Figure 6-11 Installing the USB Driver Step 2

After the driver is installed, users can see "usb test and measurement device" in the device manager of the computer. As shown in the picture below:

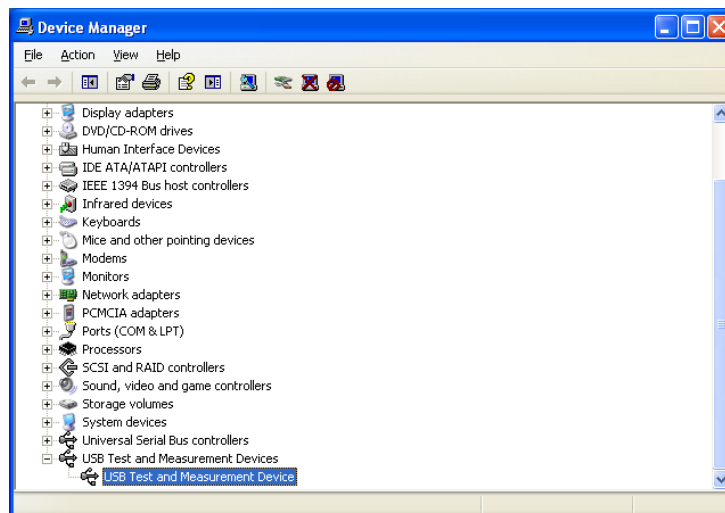

Figure 6-12 PC Device Manager showing USBTMC

Users can access the instrument through LabVIEW software programming when using the USBTMC interface.

6.4 USBVCOM Virtual Serial Port

By selecting the bus method "USBVCOM", the USB interface can be configured as a virtual serial port (VCOM).

6.4.1 System Configuration

Connect the USB port on the rear panel of the TH2518 to the USB port on the host computer via the USB cable.

6.4.2 Installation of Drivers

Download **TH2518 USBVCOM** driver from Tonghui Electronics website>Service & Support>Download Center>Software. After the driver is installed, users can see "usb VCOM PORT" in the device manager of the computer.

At this time, the usb Vcom port is equivalent to a serial port. When the PC does not have a serial port, the serial port-based communication software can be used in this mode as a virtual serial port with the USB port.

Chapter 7 TH2518 Command Set

7.1 SCPI Command Set

7.1.1 DISP Command Set

7.1.1.1 DISP:PAGE

1) Setup command:

Command	Description
DISP:PAGE MEAS	Set the display page to: <Measurement Display>.
DISP:PAGE MSET	Set the display page to: <Measurement Setting>.
DISP:PAGE CSET	Set the display page to: <Channel Setting>.
DISP:PAGE LSET	Set the display page to: <Limit Setting>.
DISP:PAGE SYST	Set the display page to: <System Settings>.
DISP:PAGE FLIS	Set the display page to: <Internal Documents>

Setup command description:

Sets the instrument display page.

2) Query command:

DISP:PAGE?

Query command description:

Queries the current display page of the instrument.

The return type is a string, and the return content is shown below:

Return Content	Description
MEAS	The current display page is: <Measurement Display
MSET	The current display page is: <Measurement Settings
CSET	The current display page is: <Channel Settings>.
LSET	The current display page is: <Limit Setting>
SYST	The current display page is: <System Settings>
FLIS	The current display page is: <Internal Documentation>

7.1.1.2 DISP:STAT

1) Setup command:

Command	Description
DISP:STAT ON	Set the display to ON
DISP:STAT OFF	Set the display to OFF

Setup command description:

Sets the display under Tools on the instrument <Measurement Display> page to ON or OFF. indicates whether or not measurement results are displayed on the current page.

2) Query command:

DISP:STAT?

Query command description:

Queries the display status of the tool on the instrument <Measurement Display> page. The return type is an integer, and the return content is as follows:

Return Content	Description
0	Display as OFF
1	Display as ON

7.1.2 FUNC Command Set

7.1.2.1 FUNC:IMP

1) Setup command:

Command	Description
FUNC:IMP R	Set the parameters on the <Measurement Settings> page to: R
FUNC:IMP RT	Set the parameters on the <Measurement Settings> page to: R-T
FUNC:IMPT	Set the parameters on the <Measurement Settings> page to: T

Setup command description:

Sets the **parameter** mode under the <Measurement Settings> page.

R denotes resistance mode; R-T denotes resistance and temperature mode; T denotes temperature mode.

2) Query command:

FUNC:IMP?

Query command description:

Queries the **parameter** mode under the <Measurement Settings> page.

The return type string, the return content is as follows:

Return Content	Description
R	The current <Measurement Settings> parameter is: R
RT	The current <Measurement Settings> parameter is: R-T
T	The current <Measurement Settings> parameter is: T

7.1.2.2 FUNC:RANG

1) Setup command:

FUNC:RANG <value>

Setup command description:

Sets the instrument <Measurement Settings> page **parameter** to a fixed value for the **range** of R or R-T. The range of <value> is from 0 to 2E+5.

Example:

FUNC:RANG 123

Sets the instrument <Measurement Setup> page **parameter** to R or R-T with a **range** of 200.

2) Query command:

FUNC:RANG?

Query command description:

Queries the **range** whose **parameter** is R or R-T on the instrument <Measurement Settings> page. The return type is a floating-point number (scientific notation) and the return content is as follows:

7.1.2.3 FUNC:RANG:MODE

1) Setup command:

Command	Description
FUNC:RANG:MODE AUTO	The range is AUTO
FUNC:RANG:MODE NOM	The range is NOM
FUNC:RANG:MODE HOLD	The range is HOLD

Setup command description:

Sets the instrument <Measurement Settings> page **parameter** to R or R-T **range**.

2) Query command:

FUNC:RANG:MODE?

Query command description:

Queries the **range** whose **parameter** is R or R-T on the instrument's <Measurement Settings> page.

The return type is a string, and the return content is as follows:

Return Content	Description
AUTO	The range is AUTO
NOM	The range is NOM
HOLD	The range is HOLD

7.1.2.4 FUNC:ADJ

1) Setup command:

FUNC:ADJ CLEAR

Setup command description:

Sets ADJ to OFF and clear the bottom data after executing 0 ADJ.

2) Query command:

FUNC:ADJ?

Query command description:

Executes the 0 ADJ of the <Measurement Display> page **tool** and returns the status of the ADJ.

The return type is an integer, and the return is as follows:

Return Content	Description
1	Execute 0 ADJ failed, ADJ is OFF
0	Execute 0 ADJ succeed, ADJ is ON

7.1.2.5 FUNC:ADJ:STAT

Query command:

FUNC:ADJ:STAT?

Query command description:

Queries the status of the 0 ADJ of the <Measurement Display> page **tool**.

The return type is an integer, and the return is as follows:

Return Content	Description
----------------	-------------

0	0 ADJ is OFF
1	0 ADJ is ON

7.1.2.6 FUNC:MUNIT

- 1) Setup command:

FUNC:MUNIT UNIT<value>

Setup command description:

When the measurement mode is Alone, sets the measurement unit in the <Measurement Display> page. <value> indicates the value of the measurement unit in the range of 1 to 6.

Example:

FUNC:MUNIT UNIT2

When the measurement mode is Alone, set the measurement unit on the <Measurement Display> page to 2.

- 2) Query command:

FUNC:MUNIT?

Query command description:

Queries the measurement unit of the <Measurement Display> page. The return type is an integer in the range 1 to 6.

7.1.3 APER Command Set

7.1.3.1 APER

- 1) Setup command:

Command	Description
APER FAST	Set the speed of the <Measurement Display> page to FAST
APER MED	Set the speed of the <Measurement Display> page to MED
APER SLOW	Set the speed of the <Measurement Display> page to SLOW

Setup command description:

Sets the speed of the instrument's <Measurement Display> page.

- 2) Query command:

APER?

Query command description:

Queries the speed of the instrument <Measurement Display> page.

The return type is a string, and the return content is as follows:

Return Content	Description
FAST	The current speed of the <measurement display> page is FAST
MED	The current speed of the <measurement display> page is MED
SLOW	The current speed of the <measurement display> page is SLOW

7.1.3.2 APER:AVER

- 1) Setup command:

APER:AVER <value>

Setup command description:

Sets the average of the instrument's <Measurement Settings> page. The range of <value> is from 1 to 255.

Example:

APER:AVER 10

Set the average of the instrument's <Measurement Settings> page to 10 times.

2) Query command:

APER:AVER?

Query command description:

Queries the average of the instrument <Measurement Settings> page. The return type is an integer, and the return range is from 1 to 255.

7.1.4 TRIG Command Set

7.1.4.1 TRIG

Setup command:

TRIG

Setup command description:

Triggers the instrument to measure once. Effective when the current trigger on the <Measurement Setup> page is BUS.

7.1.4.2 TRIG:SOUR

1) Setup command:

Command	Description
TRIG:SOUR INT	Set the trigger on the <Measurement Settings> page to INT
TRIG:SOUR MAN	Set the trigger on the <Measurement Settings> page to MAN
TRIG:SOUR EXT	Set the trigger for the <Measurement Settings> page to EXT
TRIG:SOUR BUS	Set the trigger on the <Measurement Settings> page to BUS

Setup command description:

Sets the trigger method on the instrument's <Measurement Settings> page.

INT means internally triggered.

MAN means TRIGGER key trigger.

EXT means externally triggered.

BUS refers to the upper computer command trigger.

2) Query command:

TRIG:SOUR?

Query Command description:

Queries the trigger mode of the current <Measurement Settings> page of the instrument.

The return type is a string, and the return content is as follows:

Return Content	Description
INT	The current trigger on the <Measurement Settings> page is

	INT
MAN	The current trigger on the <Measurement Settings> page is MAN
EXT	The current trigger on the <Measurement Settings> page is EXT
BUS	The current trigger on the <Measurement Settings> page is BUS

7.1.4.3 TRIG:DELAY

1) Setup command:

TRIG:DELAY <value>

Setup command description:

Sets the measurement delay time in the <Measurement Settings> page of the instrument. The range of <value> is from 0 to 9.999. units are seconds.

Example:

TRIG:DELAY 0.01

Sets the measurement delay to 10ms on the instrument <Measurement Settings> page.

2) Query command:

TRIG:DELAY?

Query command description:

Queries the measurement delay on the instrument <Measurement Settings> page. The return type is a floating-point number, and the return range is from 0 to 9.999.

7.1.4.4 TRIG:DELAY:AUTO

1) Setup command:

Command	Description
TRIG:DELAY:AUTO ON	Measurement delay is automatic on the <Measurement Settings> page.
TRIG:DELAY:AUTO OFF	Measurement delay is a numeric value on the <Measurement Settings> page.

Setup command description:

Sets whether the measurement delay on the instrument's <Measurement Settings> page is automatic or numeric.

2) Query command:

TRIG:DELAY:AUTO?

Query command description:

Queries whether the measurement delay is automatic on the instrument <Measurement Settings> page.

The return type is an integer, and the return is as follows:

Return Content	Description
0	The current measurement delay on the <Measurement Settings> page is Auto.
1	The current measurement delay on the <Measurement Settings> page is a numeric value.

7.1.5 FETC Command Set

7.1.5.1 FETC

Query command:

FETC?

Query command description:

This command is used to get the last measurement result of the instrument and the system status.

Note: This query command returns data only when the instrument is in the <Measurement Display> page.

■ Stand-alone mode (Alone)

The data returned by this command is categorized into three types according to different functions and display pages:

- 1) On the <Measurement display> page, the measurement mode is single-parameter mode (parameters are R, T)

Return data format is: <main parameter>,<system status>.

a) <main parameter>

<Main Parameter> indicates the measured value of the current parameter with a floating-point data type.

①When the measurement mode is parameter R, then <main parameter> is the measured resistance value in Ω .

②When the measurement mode is parameter T, then <main parameter> is the measured temperature in $^{\circ}\text{C}$.

③When the range is exceeded or there is a measurement error, then <main parameter> is "+9.900000E+37".

b) <system status>

<System Status> indicates the current test value status.

-1 No data in buffer.

0 General Measurement Data

+1 Measurement status error

Example:

FETC?

Return:

+2.434457E+01,+0

Indicates that the current test resistance value is 24.34457Ω and the measurement data is normal.

- 2) On the <Measurement display> page, the measurement mode is the two-parameter mode (function R-T)

Return data format is: <primary parameter>,<secondary parameter>,<system status>.

1) <primary parameter>,<secondary parameter>

<Main Parameter> Table of measured values for the current main parameter, data type is floating-point.

<Subparameter> Table of measured values of the current subparameter, data type is floating-point number.

① When the measurement mode is parameter R-T, then <primary parameter> is the measured resistance value in Ω , and <secondary parameter> is the measured temperature in $^{\circ}\text{C}$.

② When the range is exceeded or there is a measurement error, then <primary parameter> is "+9.900000E+37"; <secondary parameter> is "+9.900000E+37".

2) <system status>

<System Status> indicates the current test value status.

-1 No data in buffer.

0 General measurement data

+1 Measurement status error

Example:

FETC?

Return:

+2.434709e+01,+9.205499e+01,+0

Indicates that the current test resistance value is 24.34457 Ω , the measured temperature is 92.05499 $^{\circ}\text{C}$, and the measured data is normal.

3) Other display pages have no return value

■ Scan mode (Scan)

The return data format is:

<channel number 1>,<main parameter>,<comparison result>.

<channel number 2>,<main parameter>,<comparison result>.

<channel number 3>,<main parameter>,<comparison result>.

.

.

<channel number n>,<primary parameter>,<comparison result>.

Where <channel number 1~n> is the test channel number, which contains all the test channels in open state.

Note: If temperature compensation is turned on in resistance scan test mode, the first channel is always on and the test function is temperature.

<Main parameter>=measured value of the corresponding test channel, when over-range or there is a measurement error, the return value is "+9.90000E+37".

<comparison result> = the comparison result of the corresponding test channel. This item is returned only when the comparison is ON in the <measurement display> page, and its return value and meaning are as follows:

1 indicates that the comparison result is: pass (GD)

2 indicates that the comparison result is: above the upper limit of the comparison boundary (HI)

3 indicates that the result of the comparison is: below the lower limit of the comparison boundary (Lo)

7.1.5.2 FETC:AUTO

1) Setup command:

Command	Description
FETC:AUTO ON	Automatic return of measurement results
FETC:AUTO OFF	No automatic return of measurement results

Setup command description:

Sets whether or not the instrument automatically returns the results of each measurement.

2) Query command:

FETC:AUTO?

Query command description:

Queries whether the results of instrument measurements are returned automatically.

The return type is an integer, and the return is as follows:

Return Content	Description
0	Currently in the automatic return of measurement results state
1	Currently in the non-automatic return of measurement results state

7.1.6 TEMP Command Set

7.1.6.1 TEMP:SENS

1) Setup command:

Command	Description
TEMP:SENS PT100	The parameter sensor on the <Measurement Settings> page is PT100
TEMP:SENS PT500	The parameter sensor on the <Measurement Settings> page is PT500
TEMP:SENS ANAL	The parameter sensor on the <Measurement Settings> page is AnLG_In

Setup command description:

Sets the parameter **sensor** on the instrument's <Measurement Settings> page.

2) Query command:

TEMP:SENS?

Query command description:

Queries the parameter **sensor** on the instrument's <Measurement Settings> page.

The return type is an integer, and the return is as follows:

Return Content	Description
PT100	The current parameter sensor on the <Measurement Settings> page is PT100

PT500	The current parameter sensor on the <Measurement settings> page is PT500
ANAL	The current parameter sensor on the <Measurement Settings> page is AnLG_In

7.1.6.2 TEMP:APAR

- 1) Setup command:

TEMP:APAR <data1>,<data2>,<data3>,<data4>

Setup command description:

Sets **V1**, **T1**, **V2**, and **T2** on the instrument <Measurement Settings> page when the sensor is AnLG_In.

<data1> sets the value of the initial resistor **V1**. The range of <data1> is from 0 to 2, in V.

<data2> sets the value of the initial temperature **T1**, and <data2> ranges from -99.9 to 999.9 in degrees Celsius.

<data3> sets the value of the constant **V2**, and <data3> ranges from 0 to 2 in V.

<data4> sets the value of the constant **T2**, and <data4> ranges from -99.9 to 999.9 in °C.

Example:

TEMP:APAR 0,0,1,500

Sets the value of **V1** on the instrument <Measurement Settings> page to 0, the value of **T1** to 0, the value of **V2** to 1, and the value of **T2** to 500.

- 2) Query command:

TEMP:APAR?

Query command description:

Queries **V1**, **T1**, **V2**, and **T2** on the instrument <Measurement Settings> page. The return type is a floating-point number.

7.1.6.3 TEMP:CORR:STAT

- 1) Setup command:

Command	Description
TEMP:CORR:STAT ON	Temperature compensation is ON for the parameter on the <Measurement Settings> page.
TEMP:CORR:STAT OFF	Temperature compensation is OFF for the parameter on the <Measurement Settings> page.

Setup command description:

Sets the parameter **Temperature Compensation** on the instrument's <Measurement Settings> page.

- 2) Query command:

TEMP:CORR:STAT?

Query command description:

Queries the parameter **Temperature Compensation** on the instrument <Measurement Settings> page.

The return type is an integer, and the return is as follows:

Return Content	Description
0	The current parameter temperature compensation on the <Measurement Settings> page is OFF.
1	The current parameter temperature compensation on the <Measurement Settings> page is ON.

7.1.6.4 TEMP:CORR:PAR

1) Setup command:

TEMP:CORR:PAR <data1>,<data2>

Setup command description:

Sets **t0** and **at0** on the <Measurement Settings> page of the instrument.

<data1> sets the value of **t0** and <data1> ranges from -10.0 to 99.9 in degrees Celsius.

<data2> sets the value of **at0** and <data2> ranges from -99999 to 99999 in ppm.

Example:

TEMP:CORR:PAR 10,3930

Sets the value of **t0** to 10 and the value of **at0** to 3930 on the instrument <Measurement Settings> page.

2) Query command:

TEMP:CORR:PAR?

Query command description:

Queries **t0** and **at0** on the instrument <Measurement Settings> page. The return type is a floating-point number.

7.1.7 COMP Command Set

7.1.7.1 COMP:STAT

1) Setup command:

Command	Description
COMP:STAT ON	Parameter comparison is ON
COMP:STAT OFF	Parameter comparison is OFF

Setup command description:

Sets the parameter **comparison** on the instrument <Boundary Settings> page.

2) Query command:

COMP:STAT?

Query command description:

Queries the parameter **comparison** on the instrument <Compare Display> page.

The return type is an integer, and the return is as follows:

Return Content	Description
0	The current parameter comparison is OFF
1	The current parameter comparison is ON

7.1.7.2 COMP:BEEP {ON|OFF}

1) Setup command:

Command	Description
COMP:BEEP ON	Parameter comparison signal is ON
COMP:BEEP OFF	Parameter comparison signal is OFF

Setup command description:

Sets the parameter comparison signal for the tool on the instrument <Parameter Settings>→ <Boundary Settings> page.

2) Query command:

COMP:BEEP?

Query command description:

Queries the parameter comparison signal of the tool on the instrument <Parameter Settings>→ <Boundary Settings> page.

The return type is an integer, and the return is as follows:

Return Content	Description
ON	The current parameter comparison signal is ON.
OFF	The current parameter comparison signal is OFF.

7.1.7.3 COMP:BEEP:MODE

1) Setup command:

Command	Description
COMP:BEEP:MODE NG	The parameterized response mode is NG.
COMP:BEEP:MODE GD	The parameterized response mode is GD.

Setup command description:

Sets the parameter Audible Mode under Tools on the instrument <Boundary Settings> page.

2) Query command:

COMP:BEEP:MODE?

Query command description:

Queries the parameter Audible Mode under Tools on the instrument <Boundary Settings> page.

The return type is an integer, and the return is as follows:

Return Content	Description
NG	The current parameter comparison response is NG
GD	The current parameter comparison signal is GD

7.1.7.4 COMP:MODE

1) Setup command:

Command	Description
COMP:MODE ATOL	The parameter comparison mode is AbsDev
COMP:MODE PTOL	The parameter comparison mode is Perc
COMP:MODE ABS	The parameter comparison mode is ABS

Setup command description:

Sets the parameter **boundary mode** of the instrument <Boundary Settings> page.

2) Query command:

COMP:MODE?

Query command description:

Queries the parameter **boundary mode** on the instrument <Boundary Settings> page.

The return type is an integer, and the return is as follows:

Return Content	Description
ATOL	The current parameter boundary mode is AbsDev
PTOL	The current parameter boundary mode is Perc
ABS	The current parameter boundary mode is ABS

7.1.7.5 COMP:RES:ATOL:UPP

1) Setup command:

COMP:RES:ATOL:UPP <value>

Setup command description:

Sets the **upper limit** of the instrument <Boundary Setting> page. The range of <value> is from 0 to 2.0E+5. The unit is Ω .

Example:

COMP:RES:ATOL:UPP 2000

Sets the **upper limit** of the instrument <Boundary Setting> page to 2000 Ω .

2) Query command:

COMP:RES:ATOL:UPP?

Query command description:

Queries the **upper limit** of the instrument <Boundary Settings> page. The return type is a floating-point number, and the return range is from 0 to 2.0E+5.

Note: This command only applies to the <System Setup> page where the **measurement mode** is Alone, the <Measurement Setup> page where the **measurement parameter** is R or R-T, and the <Boundary Setup> page where the **boundary mode** is AbsDev.

7.1.7.6 COMP:RES:ATOL:LOW

1) Setup command:

COMP:RES:ATOL:LOW <value>

Setup command description:

Sets the **lower limit** when the **boundary mode** is AbsDev on the instrument <Boundary Settings> page. The range of <value> is from 0 to 2.0E+5. The unit is Ω .

Example:

COMP:RES:ATOL:LOW 1800

Sets the **lower limit** to 1800 Ω when the **boundary mode** is AbsDev on the instrument <Boundary Setting> page.

2) Query command:

COMP:RES:ATOL:LOW?

Query command description:

Queries the lower limit of the instrument <Boundary Settings> page when the boundary mode is AbsDev. The return type is a floating-point number, and the return range is from 0 to 2.0E+5.

Note: This command only applies to the <System Setup> page where the measurement mode is Alone, the <Measurement Setup> page where the measurement parameter is R or R-T, and the <Boundary Setup> page where the boundary mode is AbsDev.

7.1.7.7 COMP:RES:PTOL:UPP

1) Setup command:

COMP:RES:PTOL:UPP <value>

Setup command description:

Sets the upper limit when the boundary mode is Perc on the instrument <Boundary Settings> page. The <value> ranges from -99.99 to 99.99. units are %.

Example:

COMP:RES:PTOL:UPP 10

Sets the upper limit to 10% when the boundary mode is Perc on the instrument <Boundary Settings> page.

2) Query command:

COMP:RES:PTOL:UPP?

Query command description:

Queries the upper limit when the boundary mode of the instrument <Boundary Settings> page is Perc. The return type is a floating-point number, and the return range is from -99.99 to 99.99.

Note: This command only applies to the <System Setup> page where the measurement mode is Alone, the <Measurement Setup> page where the measurement parameter is R or R-T, and the <Boundary Setup> page where the boundary mode is Perc.

7.1.7.8 COMP:RES:PTOL:LOW

1) Setup command:

COMP:RES:PTOL:LOW <value>

Setup command description:

Sets the lower limit when the boundary mode is Perc on the instrument <Boundary Settings> page. The <value> ranges from -99.99 to 99.99. units are %.

Example:

COMP:RES:PTOL:LOW -10

Sets the lower limit to -10% when the boundary mode is Perc on the instrument <Boundary Settings> page.

2) Query command:

COMP:RES:PTOL:LOW?

Query command description:

Queries the **lower limit** when the **boundary mode** is Perc on the instrument <Boundary Settings> page. The return type is a floating-point number, and the return range is from -99.99 to 99.99.

Note: This command only applies to the <System Setup> page where the measurement mode is Alone, the <Measurement Setup> page where the measurement parameter is R or R-T, and the <Boundary Setup> page where the boundary mode is Perc.

7.1.7.9 COMP:RES:ABS:UPP

1) Setup command:

COMP:RES:ABS:UPP <value>

Setup command description:

Sets the **upper limit** when the **boundary mode** is ABS on the instrument <Boundary Setting> page. The range of <value> is from 0 to 2.0E+5. The unit is Ω .

Example:

COMP:RES:ABS:UPP 2000

Sets the **upper limit** to 2000 Ω when the **boundary mode** is ABS on the instrument <Boundary Setting> page.

2) Query command:

COMP:RES:ABS:UPP?

Query command description:

Queries the **upper limit** when the **boundary mode of the instrument** <Boundary Setting> page is ABS. The return type is a floating-point number and the return range is from 0 to 2.0E+5.

Note: This command is only applicable to the <System Setup> page where the measurement mode is Alone, the <Measurement Setup> page where the measurement parameter is R or R-T, and the <Boundary Setup> page where the boundary mode is ABS.

7.1.7.10 COMP:RES:ABS:LOW

1) Setup command:

COMP:RES:ABS:LOW <value>

Setup command description:

Sets the **lower limit** when the **boundary mode** is ABS on the instrument <Boundary Settings> page. The range of <value> is from 0 to 2.0E+5. The unit is Ω .

Example:

COMP:RES:ABS:LOW 1800

Sets the **lower limit** to 1800 Ω when the **boundary mode** is ABS on the instrument <Boundary Setting> page.

2) Query command:

COMP:RES:ABS:LOW?

Query command description:

Queries the **lower limit** when the **boundary mode of the instrument** <Boundary Setting> page is ABS. The return type is a floating-point number and the return range is from 0 to 2.0E+5.

Note: This command is only applicable to the <System Setup> page where the measurement mode is Alone, the <Measurement Setup> page where the measurement parameter is R or R-T, and the <Boundary Setup> page where the boundary mode is ABS.

7.1.7.11 COMP:RES:REF

1) Setup command:

COMP:RES:REF <value>

Setup command description:

Sets the nominal in the <Boundary Settings> page of the instrument. <value> ranges from 0 to 2.0E+5. units are Ω .

Example:

COMP:RES:REF 2000

Sets the scale of the instrument's <Boundary Settings> page to 2000 Ω .

2) Query command:

COMP:RES:REF?

Query command description:

Queries the nominal of the instrument <Boundary Settings> page. The return type is a floating-point number, and the return range is from 0 to 2.0E+5.

Note: This command only applies to the <System Setup> page where the measurement mode is Alone, the <Measurement Setup> page where the measurement parameter is R or R-T, and the <Boundary Setup> page where the boundary mode is ABS or AbsDev.

7.1.7.12 COMP:TEMP:ATOL:UPP

1) Setup command:

COMP:TEMP:ATOL:UPP <value>

Setup command description:

Sets the upper limit of the instrument's <Boundary Settings> page. The range of <value> is from -999.9 to 999.9. units are $^{\circ}\text{C}$.

Example:

COMP:TEMP:ATOL:UPP 200

Sets the upper limit of 200 $^{\circ}\text{C}$ on the instrument <Boundary Setting> page.

2) Query command:

COMP:TEMP:ATOL:UPP?

Query command description:

Queries the upper limit of the instrument <Boundary Settings> page. The return type is a floating-point number, and the return range is from -999.9 to 999.9.

Note: This command only applies to the <System Setup> page with measurement mode Alone, the <Measurement Setup> page with measurement parameter T, and the <Boundary Setup> page with boundary mode AbsDev.

7.1.7.13 COMP:TEMP:ATOL:LOW

1) Setup command:

COMP:TEMP:ATOL:LOW <value>

Setup command description:

Sets the lower limit when the boundary mode is AbsDev on the instrument <Boundary Settings> page. The range of <value> is from -999.9 to 999.9. units are °C.

Example:

COMP:TEMP:ATOL:LOW 180

Sets the lower limit to 180 °C when the boundary mode is AbsDev on the instrument <Boundary Settings> page.

2) Query command:

COMP:TEMP:ATOL:LOW?

Query command description:

Queries the lower limit of the instrument <Boundary Settings> page. The return type is a floating-point number, and the return range is from -999.9 to 999.9.

Note: This command only applies to the <System Setup> page with measurement mode Alone, the <Measurement Setup> page with measurement parameter T, and the <Boundary Setup> page with boundary mode AbsDev.

7.1.7.14 COMP:TEMP:PTOL:UPP

1) Setup command:

COMP:TEMP:PTOL:UPP <value>

Setup command description:

Sets the upper limit when the boundary mode is Perc on the instrument <Boundary Settings> page. The <value> ranges from -99.99 to 99.99. units are %.

Example:

COMP:TEMP:PTOL:UPP 10

Sets the upper limit to 10% when the boundary mode is Perc on the instrument <Boundary Settings> page.

2) Query command:

COMP:TEMP:PTOL:UPP?

Query command description:

Queries the upper limit when the boundary mode of the instrument <Boundary Settings> page is Perc. The return type is a floating-point number and the return range is from -99.99 to 99.99.

Note: This command only applies to the <System Setup> page where the measurement mode is Alone, the <Measurement Setup> page where the measurement parameter is T, and the <Boundary Setup> page where the boundary mode is Perc.

7.1.7.15 COMP:TEMP:PTOL:LOW

1) Setup command:

COMP:TEMP:PTOL:LOW <value>

Setup command description:

Sets the lower limit when the boundary mode is Perc on the instrument <Boundary Settings> page. The <value> ranges from -99.99 to 99.99. units are %.

Example:

COMP:TEMP:PTOL:LOW -10

Sets the lower limit to -10% when the boundary mode is Perc on the instrument <Boundary Settings> page.

2) Query command:

COMP:TEMP:PTOL:LOW?

Query command description:

Queries the lower limit when the boundary mode is Perc on the instrument <Boundary Settings> page. The return type is a floating-point number, and the return range is from -99.99 to 99.99.

Note: This command only applies to the <System Setup> page where the measurement mode is Alone, the <Measurement Setup> page where the measurement parameter is T, and the <Boundary Setup> page where the boundary mode is Perc.

7.1.7.16 COMP:TEMP:ABS:UPP

1) Setup command:

COMP:TEMP:ABS:UPP <value>

Setup command description:

Sets the upper limit when the boundary mode is ABS on the instrument <Boundary Setting> page. The range of <value> is from -100 to 999.9. units are °C.

Example:

COMP:TEMP:ABS:UPP 200

Sets the upper limit of 200 °C on the instrument <Boundary Setting> page.

2) Query command:

COMP:TEMP:ABS:UPP?

Query command description:

Queries the upper limit of the instrument <Boundary Settings> page. The return type is a floating-point number, and the return range is from -100 to 999.9.

Note: This command is only applicable to the <System Setup> page where the measurement mode is Alone, the <Measurement Setup> page where the measurement parameter is T, and the <Boundary Setup> page where the boundary mode is ABS.

7.1.7.17 COMP:TEMP:ABS:LOW

1) Setup command:

COMP:TEMP:ABS:LOW <value>

Setup command description:

Sets the lower limit when the boundary mode is ABS on the instrument <Boundary Settings> page. The range of <value> is from -100 to 999.9. units are °C.

Example:

COMP:TEMP:ABS:LOW 180

Sets the lower limit to 180 °C when the boundary mode is ABS on the instrument <Boundary Setting> page.

2) Query command:

COMP:TEMP:ABS:LOW?

Query command description:

Queries the lower limit when the boundary mode of the instrument <Boundary Settings> page is ABS. The return type is a floating-point number, and the return range is from -100 to 999.9.

Note: This command is only applicable to the <System Setup> page where the measurement mode is Alone, the <Measurement Setup> page where the measurement parameter is T, and the <Boundary Setup> page where the boundary mode is ABS.

7.1.7.18 COMP:TEMP:REF

1) Setup command:

COMP:TEMP:REF <value>

Setup command description:

Sets the nominal for the instrument's <Boundary Settings> page. <value> ranges from -999.9 to 999.9. units are °C.

Example:

COMP:TEMP:REF 200

Sets the nominal value of 200 °C on the instrument <Boundary Settings> page.

2) Query command:

COMP:TEMP:REF?

Query command description:

Queries the nominal of the instrument <Boundary Settings> page. The return type is a floating-point number, and the return range is from -999.9 to 999.9.

Note: This command is only applicable to the <System Setup> page where the measurement mode is Alone, the <Measurement Setup> page where the measurement parameter is T, and the <Boundary Setup> page where the boundary mode is ABS or AbsDev.

7.1.8 CHAN<n> Command Set

7.1.8.1 CHAN<n>:STAT

1) Setup command:

Command	Description
CHAN<n>:STAT ON	<Channel Settings> page channel n status is ON
CHAN<n>:STAT OFF	<Channel Settings> page Channel n status is OFF

Setup command description:

Sets the status of channel n on the instrument's <Channel Setup> page. <n> indicates the scanning test channel, ranging from 1 to 90.

Example:

CHAN2:STAT ON

The <Channel Settings> page CH02 is turned on, i.e., the small frame in front of CH02 is displayed in green.

2) Query command:

CHAN<n>:STAT?

Query command description:

Queries the status of channel n on the instrument <Boundary Settings> page.

The return type is an integer, and the return is as follows:

Return Content	Description
0	The current status of channel n on the <Channel Settings> page is OFF.
1	The current status of channel n on the <Channel Settings> page is ON.

7.1.8.2 CHAN<n>:ASSIGN

1) Setup command:

CHAN<n>:ASSIGN <data1>,<data2>,<data3>

Setup command description:

Sets the test unit, test high-end, and test low-end for channel n on the instrument <Channel Setup> page.

<n> indicates the scanning test channel, ranging from 1 to 90.

<data1> indicates the test unit number, ranging from 1 to 6, referring to test units 1 to 6, respectively.

<data2> indicates the number of the high-end test end of the test, ranging from 1 to 15, referring to the 1st to the 15th test end of the current test unit, respectively.

<data3> indicates the number of the low-end test end of the test, ranging from 1 to 15, which refers to the 1st to the 15th test single end of the current test unit, respectively.

Example:

CHAN2:ASSIGN 5,3,4

Sets channel CH02 on the instrument's <Channel Setup> page to test end 3 as the high end of the test and test end 4 as the low end of the test for test unit 5.

2) Query command:

CHAN<n>:ASSIGN?

Query command description:

Queries the test unit, test high-end, and test low-end for channel n on the instrument <Boundary Settings> page. The return type is an integer.

7.1.8.3 CHAN<n>:RES:ATOL:UPP

1) Setup command:

CHAN<n>:RES:ATOL:UPP <value>

Setup command description:

Sets the **upper limit** of channel n on the instrument <Boundary Settings> page. The range of <value> is from 0 to 2.0E+5. The unit is Ω .

Example:

CHAN1:RES:ATOL:UPP 2000

Sets the **upper limit of** channel CH01 on the instrument <Boundary Setting> page to 2000 Ω .

2) Query command:

CHAN<n>:RES:ATOL:UPP?

Query command description:

Queries the upper limit of channel n on the instrument <Boundary Settings> page. The return type is a floating-point number, and the return range is from 0 to 2.0E+5.

Note: This command only applies to the <System Setup> page where the measurement mode is Scan, the <Measurement Setup> page where the measurement parameter is R or R-T, and the <Boundary Setup> page where the boundary mode is AbsDev.

7.1.8.4 CHAN<n>:RES:ATOL:LOW

1) Setup command:

CHAN<n>:RES:ATOL:LOW <value>

Setup command description:

Sets the lower limit of channel n on the instrument <Boundary Settings> page. The range of <value> is from 0 to 2.0E+5. The unit is Ω .

Example:

CHAN1:RES:ATOL:LOW 1800

Sets the lower limit of channel CH01 on the instrument <Boundary Setting> page to 1800 Ω .

2) Query command:

CHAN<n>:RES:ATOL:LOW?

Query command description:

Queries the lower limit of channel n on the instrument <Boundary Settings> page. The return type is a floating-point number, and the return range is from 0 to 2.0E+5.

Note: This command only applies to the <System Setup> page where the measurement mode is Scan, the <Measurement Setup> page where the measurement parameter is R or R-T, and the <Boundary Setup> page where the boundary mode is AbsDev.

7.1.8.5 CHAN<n>:RES:PTOL:UPP

1) Setup command:

CHAN<n>:RES:PTOL:UPP <value>

Setup command description:

Sets the upper limit of channel n on the instrument <Boundary Settings> page. <value> ranges from -99.99 to 99.99. units are %.

Example:

CHAN1:RES:PTOL:UPP 10

Sets the upper limit of channel CH01 on the instrument <Boundary Settings> page to 10%.

2) Query command:

CHAN<n>:RES:PTOL:UPP?

Query command description:

Queries the **upper limit** of channel n on the instrument <Boundary Settings> page. The return type is a floating-point number, and the return range is from -99.99 to 99.99.

Note: This command is only applicable to the <System Setup> page where the measurement mode is Scan, the <Measurement Setup> page where the measurement parameter is R or R-T, and the <Boundary Setup> page where the boundary mode is Perc.

7.1.8.6 CHAN<n>:RES:PTOL:LOW

- 1) Setup command:

CHAN<n>:RES:PTOL:LOW <value>

Setup command description:

Sets the **lower limit** for channel n on the instrument <Boundary Settings> page. <value> ranges from -99.99 to 99.99. units are %.

Example:

CHAN1:RES:PTOL:LOW -10

Sets the **lower limit** for channel CH01 on the instrument <Boundary Settings> page to -10%.

- 2) Query command:

CHAN<n>:RES:PTOL:LOW?

Query command description:

Queries the **lower limit** of channel n on the instrument <Boundary Settings> page. The return type is a floating-point number, and the return range is from -99.99 to 99.99.

Note: This command is only applicable to the <System Setup> page where the measurement mode is Scan, the <Measurement Setup> page where the measurement parameter is R or R-T, and the <Boundary Setup> page where the boundary mode is Perc.

7.1.8.7 CHAN<n>:RES:ABS:UPP

- 1) Setup command:

CHAN<n>:RES:ABS:UPP <value>

Setup command description:

Sets the **upper limit** of channel n on the instrument <Boundary Settings> page. The range of <value> is from 0 to 2.0E+5. The unit is Ω .

Example:

CHAN1:RES:ABS:UPP 2000

Sets the **upper limit** of channel CH01 on the instrument <Boundary Setting> page to 2000 Ω .

- 2) Query command:

CHAN<n>:RES:ABS:UPP?

Query command description:

Queries the **upper limit** of channel n on the instrument <Boundary Settings> page. The return type is a floating-point number, and the return range is from 0 to 2.0E+5.

Note: This command is only applicable when the measurement mode is Scan on the <System Setup> page, the measurement parameter is R or R-T on the <Measurement Setup> page, and the boundary mode is ABS on the <Boundary Setup> page.

7.1.8.8 CHAN<n>:RES:ABS:LOW

1) Setup command:

CHAN<n>:RES:ABS:LOW <value>

Setup command description:

Sets the lower limit of channel n on the instrument <Boundary Settings> page. The range of <value> is from 0 to 2.0E+5. The unit is Ω .

Example:

CHAN1:RES:ABS:LOW 1800

Sets the lower limit of channel CH01 on the instrument <Boundary Setting> page to 1800 Ω .

2) Query command:

CHAN<n>:RES:ABS:LOW?

Query command description:

Queries the lower limit of channel n on the instrument <Boundary Settings> page. The return type is a floating-point number, and the return range is from 0 to 2.0E+5.

Note: This command is only applicable when the measurement mode is Scan on the <System Setup> page, the measurement parameter is R or R-T on the <Measurement Setup> page, and the boundary mode is ABS on the <Boundary Setup> page.

7.1.8.9 CHAN<n>:RES:REF

1) Setup command:

CHAN<n>:RES:REF <value>

Setup command description:

Sets the nominal for channel n on the instrument <Boundary Settings> page. <value> ranges from 0 to 2.0E+5. units are Ω .

Example:

CHAN1:RES:REF 2000

Sets the nominal value of channel CH01 on the instrument <Boundary Settings> page to 2000 Ω .

2) Query command:

CHAN<n>:RES:REF?

Query command description:

Queries the nominal of channel n on the instrument <Boundary Settings> page. The return type is a floating-point number, and the return range is from 0 to 2.0E+5.

Note: This command is only applicable to the <System Setup> page where the measurement mode is Scan, the <Measurement Setup> page where the measurement parameter is R or R-T, and the <Boundary Setup> page where the boundary mode is ABS or AbsDev.

7.1.8.10 CHAN<n>:TEMP:ATOL:UPP

1) Setup command:

CHAN<n>:TEMP:ATOL:UPP <value>

Setup command description:

Sets the **upper limit** of channel n on the instrument <Boundary Settings> page. The range of <value> is from -999.9 to 999.9. units are °C.

Example:

CHAN1:TEMP:ATOL:UPP 200

Sets the **upper limit of** channel CH01 on the instrument <Boundary Setting> page to 200 °C.

2) Query command:

CHAN<n>:TEMP:ATOL:UPP?

Query command description:

Queries the **upper limit** of channel n on the instrument <Boundary Settings> page. The return type is a floating-point number, and the return range is from -999.9 to 999.9.

Note: This command only applies to the <System Setup> page where the measurement mode is Scan, the <Measurement Setup> page where the measurement parameter is T, and the <Boundary Setup> page where the boundary mode is AbsDev.

7.1.8.11 CHAN<n>:TEMP:ATOL:LOW

1) Setup command:

CHAN<n>:TEMP:ATOL:LOW <value>

Setup command description:

Sets the **lower limit** for channel n on the instrument <Boundary Settings> page. The range of <value> is from -999.9 to 999.9. units are °C.

Example:

CHAN1:TEMP:ATOL:LOW 180

Sets the **lower limit** for channel CH01 on the instrument <Boundary Settings> page to 180 °C.

2) Query command:

CHAN<n>:TEMP:ATOL:LOW?

Query command description:

Queries the **lower limit** of channel n on the instrument <Boundary Settings> page. The return type is a floating-point number, and the return range is from -999.9 to 999.9.

Note: This command only applies to the <System Setup> page where the measurement mode is Scan, the <Measurement Setup> page where the measurement parameter is T, and the <Boundary Setup> page where the boundary mode is AbsDev.

7.1.8.12 CHAN<n>:TEMP:PTOL:UPP

1) Setup command:

CHAN<n>:TEMP:PTOL:UPP <value>

Setup command description:

Sets the upper limit of channel n on the instrument <Boundary Settings> page. <value> ranges from -99.99 to 99.99. units are %.

Example:

```
CHAN1:TEMP:PTOL:UPP 10
```

Sets the upper limit of channel CH01 on the instrument <Boundary Settings> page to 10%.

2) Query command:

```
CHAN<n>:TEMP:PTOL:UPP?
```

Query command description:

Queries the upper limit of channel n on the instrument <Boundary Settings> page. The return type is a floating-point number, and the return range is from -99.99 to 99.99.

Note: This command is only applicable to the <System Setup> page where the measurement mode is Scan, the <Measurement Setup> page where the measurement parameter is T, and the <Boundary Setup> page where the boundary mode is Perc.

7.1.8.13 CHAN<n>:TEMP:PTOL:LOW

1) Setup command:

```
CHAN<n>:TEMP:PTOL:LOW <value>
```

Setup command description:

Sets the lower limit for channel n on the instrument <Boundary Settings> page. <value> ranges from -99.99 to 99.99. units are %.

Example:

```
CHAN1:TEMP:PTOL:LOW -10
```

Sets the lower limit for channel CH01 on the instrument <Boundary Settings> page to -10%.

2) Query command:

```
CHAN<n>:TEMP:PTOL:LOW?
```

Query command description:

Queries the lower limit of channel n on the instrument <Boundary Settings> page. The return type is a floating-point number, and the return range is from -99.99 to 99.99.

Note: This command is only applicable to the <System Setup> page where the measurement mode is Scan, the <Measurement Setup> page where the measurement parameter is T, and the <Boundary Setup> page where the boundary mode is Perc.

7.1.8.14 CHAN<n>:TEMP:ABS:UPP

1) Setup command:

```
CHAN<n>:TEMP:ABS:UPP <value>
```

Setup command description:

Sets the upper limit of channel n on the instrument <Boundary Settings> page. The range of <value> is from -100 to 999.9. in °C.

Example:

```
CHAN1:TEMP:ABS:UPP 200
```

Sets the **upper limit** of channel CH01 on the instrument <Boundary Setting> page to 200 °C.

2) Query command:

CHAN<n>:TEMP:ABS:UPP?

Query command description:

Queries the **upper limit** of channel n on the instrument <Boundary Settings> page. The return type is a floating-point number, and the return range is from -100 to 999.9.

Note: This command is only applicable when the measurement mode is Scan on the <System Setup> page, the measurement parameter is T on the <Measurement Setup> page, and the boundary mode is ABS on the <Boundary Setup> page.

7.1.8.15 CHAN<n>:TEMP:ABS:LOW

1) Setup command:

CHAN<n>:TEMP:ABS:LOW <value>

Setup command description:

Sets the **lower limit** for channel n on the instrument <Boundary Settings> page. <value> ranges from -100 to 999.9. in °C.

Example:

CHAN1:TEMP:ABS:LOW 180

Sets the **lower limit** for channel CH01 on the instrument <Boundary Settings> page to 180 °C.

2) Query command:

CHAN<n>:TEMP:ABS:LOW?

Query command description:

Queries the **lower limit** of channel n on the instrument <Boundary Settings> page. The return type is a floating-point number, and the return range is from -100 to 999.9.

Note: This command is only applicable when the measurement mode is Scan on the <System Setup> page, the measurement parameter is T on the <Measurement Setup> page, and the boundary mode is ABS on the <Boundary Setup> page.

7.1.8.16 CHAN<n>:TEMP:REF

1) Setup command:

CHAN<n>:TEMP:REF <value>

Setup command description:

Sets the **nominal** for channel n on the instrument <Boundary Settings> page. <value> ranges from -999.9 to 999.9. units are °C.

Example:

CHAN1:TEMP:REF 200

Sets the **nominal** value of channel CH01 on the instrument <Boundary Settings> page to 200 °C.

2) Query command:

CHAN<n>:TEMP:REF?

Query command description:

Queries the **nominal** of channel n on the instrument <Boundary Settings> page. The return type is a floating-point number, and the return range is from -999.9 to 999.9.

Note: This command only applies to the <System Setup> page where the **measurement mode** is Scan, the <Measurement Setup> page where the **measurement parameter** is T, and the <Boundary Setup> page where the **boundary mode** is ABS or AbsDev.

7.1.9 SYST command set

7.1.9.1 SYST:MEASMODE

1) Setup command:

Command	Description
SYST:MEASMODE SCAN	Set the measurement mode on the <System Settings> page to: Scan
SYST:MEASMODE ALON	Set the measurement mode on the <System Settings> page to: Alone

Setup command description:

Sets the **measurement mode** on the <System Settings> page.

Scan indicates scanning mode; Alone indicates stand-alone mode.

2) Query command:

SYST:MEASMODE?

Query command description:

Queries the **measurement mode** on the <System Settings> page.

The return type string, the return content is as follows:

Return Content	Description
SCAN	The current measurement mode on the <System Settings> page is: Scan
ALON	The current measurement mode on the <System Settings> page is: Alone

7.1.9.2 SYST:BEEP:STAT

1) Setup command:

Command	Description
SYST:BEEP:STAT ON	Set the touch tone on the <System Settings> page to ON
SYST:BEEP:STAT OFF	Set the touch tone on the <System Settings> page to OFF

Setup command description:

Sets the **touch tone** for the instrument's <System Settings> page.

ON indicates that the instrument's touch tone function is turned on, and OFF indicates that the instrument's touch tone function is turned off.

2) Query command:

SYST:BEEP:STAT?

Query command description:

Queries the **touch tone** of the instrument's <System Settings> page.

The return type is an integer, and the return is as follows:

Return Content	Description
0	The current touch tone on the <System Settings> page is OFF
1	The current touch tone on the <System Settings> page is ON

7.1.9.3 SYST:SHIF

1) Setup command:

Command	Description
SYST:SHIF ON	Set the shift output on the <System Settings> page to ON.
SYST:SHIF OFF	Set the shift output on the <System Settings> page to OFF.

Setup command description:

Sets the shift output of the instrument's <System Setup> page.

2) Query command:

SYST:SHIF?

Query command description:

Queries the shift output of the instrument <System Settings> page.

The return type is an integer, and the return is as follows:

Return Content	Description
0	The current shift output on the <System Settings> page is OFF.
1	The current shift output on the <System Settings> page is ON.

7.1.9.4 SYST:LFR

1) Setup command:

Command	Description
SYST:LFR 50	Set the power supply frequency to 50 on the <System Settings> page.
SYST:LFR 60	Set the power frequency to 60 on the <System Settings> page.

Setup command description:

Sets the power supply frequency on the instrument's <System Settings> page.

2) Query command:

SYST:LFR?

Query command description:

Queries the power supply frequency on the instrument's <System Settings> page.

The return type is an integer, and the return is as follows:

Return Content	Description
0	The current power frequency on the <System Settings> page is 50
1	The current power frequency on the <System Settings> page is 60

7.1.9.5 SYST:EXTVCC

1) Setup command:

Command	Description
SYST:EXVCC INT	Set the Hdl power supply on the <System Settings> page to internal
SYST:EXTVCC EXT	Set the Hdl power supply on the <System Settings> page to external

Setup command description:

Sets the Hdl power supply on the instrument's <System Setup> page.

2) Query command:

SYST:EXTVCC?

Query command description:

Queries the Hdl power supply on the instrument's <System Setup> page.

The return type is an integer, and the return is as follows:

Return Content	Description
INT	The current Hdl power supply on the <System Settings> page is internal
EXT	The current Hdl power supply on the <System Settings> page is external

7.1.9.6 SYST:SAVE

Setup command:

SYST:SAVE <data1>,<data2>

Setup command description:

Saves the current parameter settings of the instrument to an internal file.

<data1> refers to the serial number of the saved file, ranging from 1 to 30.

<data2> refers to the name of the file to be saved (without the suffix .STA and no more than 8 characters in length).

Example:

SYST:SAVE 2,abc

The current parameter settings of the instrument are saved to file number 2 with the file name abc. you can see the abc file in serial number 2 on the <Internal Files> page.

7.1.9.7 SYST:LOAD

Setup command:

SYST:LOAD <value>

Setup command description:

Loads the saved parameter setting file.

<value> refers to the serial number of the saved file, ranging from 1 to 30.

Note: The file to be loaded must have been saved, otherwise the command is ignored!

Example:

SYST:LOAD 2

Loads the <Internal Documents> page serial number 2 file.

7.1.9.8 SYST:RESET

Setup command:

SYST:RESET

Setup command description:

Triggers a system reset for the <System Settings> page tool.

7.1.9.9 SYST:PUMP

Setup command:

Command	Description
SYST:PUMP ON	Handler interface pin 7 (PUMP) outputs high level
SYST:PUMP OFF	Handler interface pin 7 (PUMP) outputs low level

Setup command description:

Controls the output level of Handler interface pin 7 (PUMP).

7.1.10 SCPI Public Command**7.1.10.1 *RST**

Setup command:

***RST**

Setup command description:

Resets the instrument to factory settings.

7.1.10.2 *TRG

Setup command:

***TRG**

Setup command description:

Triggers an instrument measurement and returns the measurement result. This command is valid when the trigger on the <Measurement Setup> page is BUS.

7.1.10.3 *IDN?

Setup command:

***IDN?**

Setup command description:

Returns the model number of the instrument.

7.2 SCPI Protocol Debugging

7.2.1 Instrument Settings



6-14 SCPI Settings

Sets the bus mode to RS232C, set the baud rate to 9600, and set the PROTO to SCPI in Tools.

7.2.2 Debugging Assistant Download

Download **SSCOM3.2 Serial Debugging Assistant compatible with WIN10** from the official website of Tonghui Electronics>Service and Support>Download Center>Software at <http://www.tonghui.com.cn/cn/upload/Download/20191209144423178.rar>.

7.2.3 Instrument Commissioning

- 1) Use a **serial crossover cable** to connect the computer to the instrument.
- 2) Unzip the downloaded RAR file and open **Serial Debugging Assistant.exe**.
- 3) View the serial port number.

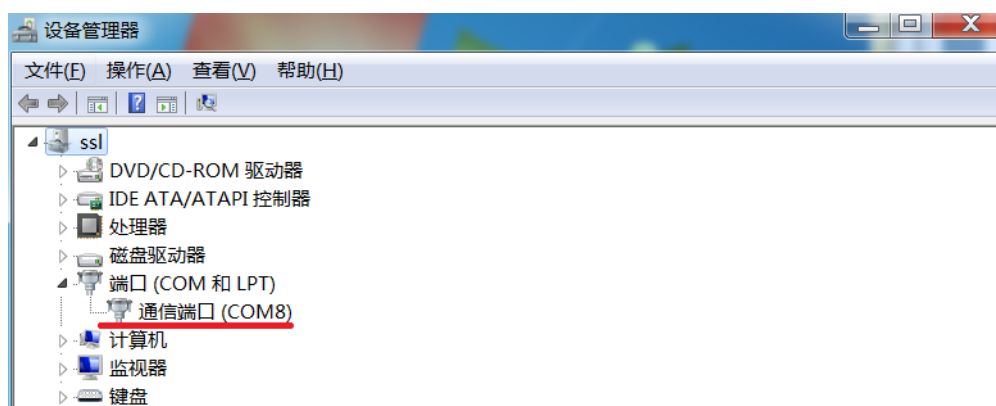

Figure 6-15 Serial Port Number

- 4) Set up the **SSCOM3.2 serial port debugging assistant**.



Figure 6-16 SSCOM3.2 Software Settings

- Follow step 3) to set the serial port number.
- Follow the baud rate settings on the instrument's <System Settings> page. Click Open Serial Port when the settings are complete.
- Click **Send New Line** on the serial port software (no data is returned without clicking Send New Line)

Note: This version of the serial port debugging assistant do not use the keyboard to operate the paste, copy and other operations, you can use the right mouse button of the paste, copy operation, otherwise there will be no return to send the command instrument phenomenon!

- Send *idn?



Figure 6-17 Send *idn?

If there is data returned, debugging is successful. **If no data is returned, please confirm.**

- See section 6.1 for whether the serial cable has pins 2 and 3 crossed. If it is a USB to serial cable, you need to determine whether pins 2 and 3 are crossed.
- Is there a problem with the instrument settings (baud rate, port number, **PROTO**).

7.2.4 Getting Measurement Results

Note: The instrument returns measurement data only in the <Measurement Display> page.

7.2.4.1 Non-automatic

The first:

①Set Instrument <Parameter Setup>→ <Measurement Setup>→ Trigger Mode to BUS.

②TRIG

③FETC?

Get the measurement again repeat sending②③ .

The second:

①Set Instrument <Parameter Setup>→ <Measurement Setup>→ Trigger Mode to BUS.

②*TRG

①It is an initialization command, which is sent only once, and is repeated at② to get the measurement result again.

7.2.4.2 Semi-automatic (Recommended)

①Set Instrument <Parameter Setup>→ <Measurement Setup>→ Trigger Mode to BUS.

②Set Instrument <System Setup>→ <Tools>→ FetcAuto to ON.(Switchboard Save)

③TRIG

Get the measurement result again to repeat the operation③ , pay attention to the interval of sending TRIG, the conventional operation is to wait until the host computer reads the test data, and then send the next TRIG Command.

7.2.4.3 Fully Automatic

①Set Instrument <Parameter Setup>→ <Measurement Setup>→ Trigger Mode to INT.

②Set Instrument <System Setup>→ <Tools>→ FetcAuto to ON. (Switchboard Save)

The instrument automatically sends return data each time a measurement is completed.

7.3 MODBUS System Commands

7.3.1 MODBUS Protocol Description

7.3.1.1 Write Command Description

Send Format:

0	1	2	3	4	5	6	7	8	9	10	11	12
Send Address	Function Code	Address High	Address Low	Register Number High	Register Number Low	Byte Count	Data Byte 1	Data Byte 2	Data Byte N	CR C Low	CR C High

Return Format:

0	1	2	3	4	5	6	7
Send Address	Function Code	Address High	Address Low	Register Number High	Register Number Low	CRC Low	CRC High

1) Send Address

The transmit address is the local address of the instrument, which can be set in the parameter bus address of the communication setting interface of the instrument, and the value range is: 1~31.

2) Function Code

The write Command Function Code is: 0x10.

3) Address High

The address is the address at which the data is stored on the instrument, and the address high bit is the upper eight bits of the address.

4) Address Low

The address is the address at which the data is stored on the instrument, and the address high bit is the lower eight bits of the address.

5) Register Number High and Register Number Low

The number of registers indicates the number of registers required for this operation. If it is 2 bytes of data, the number of registers is 1; if it is 4 bytes of data, the number of registers is 2; if it is 8 bytes of data, the number of registers is 4.

6) Byte Count

The number of data indicates the total number of data written for this operation. The total number of bytes is always two times the number of registers.

7) Data byte 1~Data byte n

The data byte is to write the set data content to the instrument. The **high byte bit comes first, and the low byte bit comes second.**

If the total number of bytes is 2, data byte 1 belongs to the high 8 bits and data byte 2 data low 8 bits, forming a 16-bit integer.

If the total number of bytes is 4, data byte 1 belongs to the highest 8 bits of the floating-point number, data byte 4 data lowest 8 bits, data byte 1 to data byte 4 form a floating-point number.

For example, decimal number 25.16, converted hexadecimal number is 0x41 0xC9 0x47 0xAE, then data byte 1 is 0x41, data byte 2 is 0xC9, data byte 3 is 0x47, data byte 4 is 0xAE. if stored in a 4-byte array, then a[0]=0xAE, a[1]=0x47, a[2]=0xC9, a[3]= 0x41.

If the total number of bytes is 8, data byte 1 through data byte 4 form the first floating-point number, and data byte 5 through data byte 8 form the second floating-point number.

8) CRC High and CRC Low

CRC 16-bit checksums, using the lookup table method for CRC checksums. See section 7.3.3 for details.

7.3.1.2 Read Command Description

Send Format:

0	1	2	3	4	5	6	7
Send Address	Function Code	Address High	Address Low	Register Number High	Register Number Low	CRC Low	CRC High

Return Format:

0	1	2	3	4	5	6	7	8
Send Address	Function Code	Byte Count	Data Byte 1	Data Byte 2	Data Byte N	CRC Low	CRC High

1) Send Address

The transmit address is the local address of the instrument, which can be set in the parameter bus address of the communication setting interface of the instrument, and the value range is: 1~31.

2) Function Code

The read Command Function Code is: 0x03.

3) Address High

The address is the address at which the data is stored on the instrument, and the address high bit is the upper eight bits of the address.

4) Address Low

The address is the address at which the data is stored on the instrument, and the address high bit is the lower eight bits of the address.

5) Register Number High and Register Number Low

The number of registers indicates the number of registers required for this operation. If it is 2 bytes of data, the number of registers is 1; if it is 4 bytes of data, the number of registers is 2; if it is 8 bytes of data, the number of registers is 4.

6) Byte Count

The total number of bytes indicates the total number of data returned by this operation. The total number of bytes is always twice the number of registers.

7) Data byte 1~Data byte n

The data byte is to return the set data content to the sender.

If the total number of bytes is 2, data byte 1 belongs to the high 8 bits and data byte 2 data low 8 bits, forming a 16-bit integer.

If the total number of bytes is 4, data byte 1 belongs to the highest 8 bits of the floating-point number, data byte 4 data lowest 8 bits, data byte 1 to data byte 4 form a floating-point number.

For example, decimal number 25.16, converted hexadecimal number is 0x41 0xC9 0x47 0xAE, then data byte 1 is 0xAE, data byte 2 is 0x47, data byte 3 is 0xC9, data byte 4 is 0x41. If stored as a 4-byte array, then a[0]=0xAE, a[1]=0x47, a[2]=0xC9, a[3]= 0x41.

If the total number of bytes is 8, data byte 1 through data byte 4 form the first floating-point number and data byte 5 through data byte 8 form the second floating-point number.

8) CRC High and CRC Low

CRC 16-bit checksums, using the lookup table method for CRC checksums. See section 7.3.3 for details.

7.3.2 Public Command Description

7.3.2.1 Address 0x0001 (Reset)

Write command:

Send Address	Function Code	Address High	Address Low	Register High	Register Low	Byte Count	Data 1~2	CRC
0x01~0x1F	0x10	0x00	0x01	0x00	0x01	0x02	0	Calculation by table look-up method

Command description:

Resets the instrument.

7.3.2.2 Address 0x0002 (Auto return to TRIG)

Read command:

Send Address	Function Code	Address High	Address Low	Register High	Register Low	CRC
0x01~0x1F	0x03	0x00	0x02	0x00	0x01	Calculation by table look-up method

- 1) **Measurement mode is Alone on the <System Setup> page, and the comparison under <Measurement Display> is OFF.** the command is returned when the measurement function is in one-parameter mode (R or T):

Send Address	Function Code	Byte Count	Data 1 to 4	CRC
0x01~0x1F	0x03	0x04	-3.4E+38~3.4E+38	Calculation by table look-up method

Data 1~4 indicates the test resistance value or temperature value.

- 2) **Measurement mode is Alone on the <System Setup> page, and Comparison under <Measurement Display> is ON.** the command is returned when the measurement function is in one-parameter mode (R or T):

Send Address	Function Code	Byte Count	Data 1 to 4	Data 5~8	CRC
0x01~0x1F	0x03	0x08	-3.4E+38~3.4E+38	1~3	Calculation by table look-up method

Data 1~4 indicate the test resistance value or temperature value, and data 5~8 indicate the comparison result.

- 3) **Measurement mode is Alone on the <System Setup> page, and comparison under <Measurement Display> is OFF.** return command when the measurement function is in two-parameter mode (R-T):

Send Address	Function Code	Byte Count	Data 1 to 4	Data 5~8	CRC
0x01~0x1F	0x03	0x08	-3.4E+38~3.4E+38	-3.4E+38~3.4E+38	Calculation by table look-up method

Data 1 to 4 indicate the test resistance value, and data 5 to 8 indicate the test temperature value.

- 4) **Measurement mode is Alone on the <System Setup> page, and Comparison under <Measurement Display> is ON.** the command is returned when the measurement function is in the two-parameter mode (R-T):

Send Address	Function Code	Byte Count	Data 1 to 4	Data 5~8	Data 9 to 12	CRC
0x01~0x1F	0x03	0x0C	-3.4E+38~3.4E+38	-3.4E+38~3.4E+38	1~3	Calculation by table look-up method

Data 1~4 indicate the test resistance value, data 5~8 indicate the test temperature value, and data 9~12 indicate the comparison result.

- 5) **Measurement mode is Scan on the <System Setup> page, and comparison under <Measurement Display> is OFF.** the command is returned when the measurement function is in one-parameter mode (R or T):

Send Address	Function Code	Byte Count	Data 1 to 4	Data 5~8	Data 9 to 12	Data 13-16	Data n~n+3	Data n+4~n+7	CRC
0x01~0x1F	0x03	0x04	1~90	-3.4E+38~3.4E+38	1~90	-3.4E+38~3.4E+38	Calculation by table look-up method

Data 1~4 indicates the open channel number, and data 5~8 indicates the corresponding test resistance value or temperature value of the channel.

Data 9~12 indicate the open channel number, and data 13~16 indicate the corresponding test resistance value or temperature value of the channel.

Data n~n+3 indicates the open channel number, and data n+4~n+7 indicates the corresponding test resistance value or temperature value of the channel.

- 6) **Measurement mode is Scan on the <System Setup> page, and Comparison is ON under <Measurement Display>.** returns to the command when the measurement function is in the two-parameter mode (R or T):

Send Address	Function Code	Byte Count	Data 1 to 4	Data 5~8	Data 9 to 12	Data 13-16	Data 17-20	Data 21-24	Data n~n+3	Data n+4~n+7	Data n+8~n+11	CRC
0x01~0x1F	0x03	0x04	1~90	-3.4E+38~3.4E+38	1~3	1~90	-3.4E+38~3.4E+38	1~3	1~3	Calculation by table look-up method

Data 1~4 indicate the open channel number, data 5~8 indicate the corresponding test resistance value or temperature value of the channel, and data 9~12 indicate the comparison result.

Data 13~16 indicate the open channel number, data 17~20 indicate the corresponding test resistance value or temperature value of the channel, and data 21~24 indicate the comparison result.

Data n~n+3 indicates the open channel number, data n+4~n+7 indicates the corresponding test resistance value or temperature value of the channel, and data n+4~n+7 indicates the comparison result.

Command description:

Each time the host computer sends this command to trigger the instrument measurement, it automatically returns the measured value.

Note: When this Command is used, the trigger method must be BUS and the address 0x0019 Auto Acquire is set to Auto.

7.3.2.3 Address 0x0003 (Instrument Model)

Read command:

Send Address	Function Code	Address High	Address Low	Register High	Register Low	CRC
0x01~0x1F	0x03	0x00	0x03	0x00	0x01	Calculation by table look-up method

Return command:

Send Address	Function Code	Byte Count	Data 1~2	CRC
0x01~0x1F	0x03	0x02	0~3	Calculation by table look-up method

Command description:

Returns the model number of the instrument. 0 indicates TH2518; 1 indicates TH2518A.

7.3.3 DISP Command Description

7.3.3.1 Address 0x0004 (Display Page)

1) Write command:

Send Address	Function Code	Address High	Address Low	Register High	Register Low	Byte Count	Data 1~2	CRC
0x01~0x1F	0x10	0x00	0x04	0x00	0x01	0x02	0~5	Calculation by table look-up method

Description: Sets the display page of the instrument.

- 0 indicates the <Measurement Display> page.
- 1 indicates the <Measurement Settings> page.
- 2 indicates the <Channel Settings> page.
- 3 indicates the <Limit Settings> page.
- 4 indicates the <System Settings> page.
- 5 indicates the <Internal Documents> page.
- 5 indicates the file list (internal).

2) Read command:

Send Address	Function Code	Address High	Address Low	Register High	Register Low	CRC
0x01~0x1F	0x03	0x00	0x04	0x00	0x01	Calculation by table look-up method

Return command:

Send Address	Function Code	Byte Count	Data 1~2	CRC
0x01~0x1F	0x03	0x02	0~5	Calculation by table look-up method

Description: Queries the current display page of the instrument and return double-byte integer data.

- 0 indicates the <Measurement Display> page.
- 1 indicates the <Measurement Settings> page.
- 2 indicates the <Channel Settings> page.
- 3 indicates the <Limit Settings> page.
- 4 indicates the <System Settings> page.
- 5 indicates the <Internal Documents> page.
- 5 indicates the file list (internal).

7.3.3.2 Address 0x0005 (Measured Value Display)

1) Write command:

Send Address	Function Code	Address High	Address Low	Register High	Address Low	Byte Count	digital	CRC
0x01~0x1F	0x10	0x00	0x05	0x00	0x01	0x02	0 or 1	Calculation by table look-up method

Command description:

Sets the **display** status under **Tools** on the instrument <Measurement Display> page.

0 means "OFF" and 1 means "ON".

2) Read command:

Send Address	Function Code	Address High	Address Low	Register High	Address Low	CRC
0x01~0x1F	0x03	0x00	0x05	0x00	0x01	Calculation by table look-up method

Return command:

Send Address	Function Code	Byte Count	Data 1~2	CRC
0x01~0x1F	0x03	0x02	0 or 1	Calculation by table look-up method

Return command description: Queries the **display** status under **Tools** on the instrument <Measurement Display> page.

0 means "OFF" and 1 means "ON".

7.3.4 FUNC Command Description

7.3.4.1 Address 0x0006 (Parameter)

1) Write command:

Send Address	Function Code	Address High	Address Low	Register High	Address Low	Byte Count	Data 1~2	CRC
0x01~0x1F	0x10	0x00	0x06	0x00	0x01	0x02	0~2	Calculation by table look-up method

Description: Sets the **parameters** of the instrument <Measurement Settings>.

0 indicates that the **parameter** of <Measurement Setting> is set to R.

1 indicates that the **parameter** of <Measurement Setting> is set to RT.

2 indicates that the **parameter** of <Measurement Setting> is set to T.

2) Read command:

Send Address	Function Code	Address High	Address Low	Register High	Address Low	CRC
0x01~0x1F	0x03	0x00	0x06	0x00	0x01	Calculation by table look-up method

Return command:

Send Address	Function Code	Byte Count	Data 1~2	CRC
0x01~0x1F	0x03	0x02	0~2	Calculation by table look-up method

Description: Queries the **parameter** of instrument <Measurement Setting>, return double-byte integer data.

0 indicates that the **parameter** of <Measurement Setting> is R.

1 indicates that the **parameter** of <Measurement Setting> is RT.

2 indicates that the **parameter** of <Measurement Setting> is T.

7.3.4.2 Address 0x0007 (R range)

1) Write command:

Send Address	Function Code	Address High	Address Low	Register High	Address Low	Byte Count	Data 1 to 4	CRC
0x01~0x1F	0x10	0x00	0x07	0x00	0x02	0x04	0~2E+5	Calculation by table look-up method

Description: Sets the **range** for which the **parameter** under Instrument <Measurement Setup> is R or R-T. Write 4-byte floating-point type data contents as follows:

200.00e-3, 2000.0e-3, 20.000e+0, 200.00e+0, 2000.0e+0, 20.000e+3, 200.00e+3

2) Read command:

Send Address	Function Code	Address High	Address Low	Register High	Address Low	CRC
0x01~0x1F	0x03	0x00	0x07	0x00	0x02	Calculation by table look-up method

Return command:

Send Address	Function Code	Byte Count	Data 1 to 4	CRC
0x01~0x1F	0x03	0x04	0~2E+5	Calculation by table look-up method

Description: Queries the **range** whose **parameter** is R or R-T under the instrument <Measurement Setting> and return four-byte integer data. The return content is as follows:

200.00e-3, 2000.0e-3, 20.000e+0, 200.00e+0, 2000.0e+0, 20.000e+3, 200.00e+3

7.3.4.3 Address 0x0008 (Range Mode)

1) Write command:

Send Address	Function Code	Address High	Address Low	Register High	Address Low	Byte Count	Data 1~2	CRC
0x01~0x1F	0x10	0x00	0x08	0x00	0x01	0x02	0~2	Calculation by table look-up method

Command description:

Sets the **parameters** under Instrument <Measurement Settings> to R, R-T, and T **range**.

0 means AUTO; 1 means NOMINAL and 1 means HOLD.

2) Read command:

Send Address	Function Code	Address High	Address Low	Register High	Address Low	CRC
0x01~0x1F	0x03	0x00	0x08	0x00	0x01	Calculation by table look-up method

Return command:

Send Address	Function Code	Byte Count	Data 1~2	CRC
0x01~0x1F	0x03	0x02	0~2	Calculation by table look-up method

Explanation: Queries to set the **range** of R, R-T, and T under the **parameter** <Measurement Settings> of the instrument.

0 means AUTO; 1 means NOMINAL and 1 means HOLD.

7.3.4.4 Address 0x0009 (0 ADJ)

1) Write command:

Send Address	Function Code	Address High	Address Low	Register High	Address Low	Byte Count	Data 1~2	CRC
0x01~0x1F	0x10	0x00	0x09	0x00	0x01	0x02	0	Calculation by table look-up method

Command description:

Bottom data after clearing 0 ADJ.

2) Read command:

Send Address	Function Code	Address High	Address Low	Register High	Address Low	CRC
0x01~0x1F	0x03	0x00	0x09	0x00	0x01	Calculation by table look-up method

Return command:

Send Address	Function Code	Byte Count	Data 1~2	CRC
0x01~0x1F	0x03	0x02	0 or 1	Calculation by table look-up method

Description: Executes the 0 ADJ of the <Measurement Display> page tool.

1 indicates that execution of the 0 ADJ fail.

0 indicates that execution of the 0 ADJ succeed.

7.3.4.5 Address 0x000A (0 ADJ Status)

1) Write command:

Send Address	Function Code	Address High	Address Low	Register High	Address Low	Byte Count	Data 1~2	CRC
0x01~0x1F	0x10	0x00	0x0A	0x00	0x01	0x02	0 or 1	Calculation by table look-up method

Command description:

Sets the ADJ status of the <Measurement Display> page tool.

2) Read command:

Send Address	Function Code	Address High	Address Low	Register High	Address Low	CRC
0x01~0x1F	0x03	0x00	0x0A	0x00	0x01	Calculation by table look-up method

Return command:

Send Address	Function Code	Byte Count	Data 1~2	CRC
0x01~0x1F	0x03	0x02	0 or 1	Calculation by table look-up method

Returns the command description:

Queries the ADJ status of the <measurement display> page tool.

0 means 0 ADJ is OFF.

1 means 0 ADJ is ON.

7.3.4.6 Address 0x000B (Measuring Unit)

1) Write command:

Send Address	Function Code	Address High	Address Low	Register High	Address Low	Byte Count	Data 1~2	CRC
0x01~0x1F	0x10	0x00	0x0B	0x00	0x01	0x02	0~6	Calculation by table look-up method

Command description:

Sets the test unit for the <Measurement Display> page when the instrument is in stand-alone test mode.

2) Read command:

Send Address	Function Code	Address High	Address Low	Register High	Address Low	CRC
0x01~0x1F	0x03	0x00	0x0B	0x00	0x01	Calculation by table look-up method

Return command:

Send Address	Function Code	Byte Count	Data 1~2	CRC
0x01~0x1F	0x03	0x02	0~6	Calculation by table look-up method

Description: Queries the **test unit** on the <Measurement Display> page when the instrument is in stand-alone test mode.

7.3.5 APER Command Description

7.3.5.1 Address 0x000C (Speed)

1) Write command:

Send Address	Function Code	Address High	Address Low	Register High	Register Low	Byte Count	Data 1~2	CRC
0x01~0x1F	0x10	0x00	0x0C	0x00	0x01	0x02	0~2	Calculation by table look-up method

Command description:

Sets the **speed** under the instrument <Measurement Settings>.

0 indicates that the **speed** under <Measurement Settings> is FAST.

1 indicates that the **speed** under <Measurement Setting> is MED.

2 indicates that the **speed** under <Measurement Settings> is SLOW.

2) Read command:

Send Address	Function Code	Address High	Address Low	Register High	Register Low	CRC
0x01~0x1F	0x03	0x00	0x0C	0x00	0x01	Calculation by table look-up method

Return command:

Send Address	Function Code	Byte Count	Data 1~2	CRC
0x01~0x1F	0x03	0x02	0~2	Calculation by table look-up method

Description:

Queries the **speed** under Instrument <Measurement Settings>. Returns data of integer type, returning data from 0 to 2.

7.3.5.2 Address 0x000D (Average)

Write command:

Send Address	Function Code	Address High	Address Low	Register High	Register Low	Byte Count	Data 1~2	CRC
0x01~0x1F	0x10	0x00	0x0D	0x00	0x01	0x02	1~255	Calculation by table look-up method

Command description:

Sets the **average** on the instrument <Measurement Settings> page. The range of data 1 to 2 is from 1 to 255.

Read command:

Send Address	Function Code	Address High	Address Low	Register High	Register Low	CRC
0x01~0x1F	0x03	0x00	0x0D	0x00	0x01	Calculation by table look-up method

Return command:

Send Address	Function Code	Byte Count	Data 1~2	CRC
0x01~0x1F	0x03	0x02	1~255	Calculation by table look-up method

Description:

Queries the **average** of the instrument <Measurement Settings> page. Returns integer type data, returning data from 1 to 255.

7.3.6 TRIG Command Description

7.3.6.1 Address 0x000E (Non-automatic Return TRIG)

Write command:

Send Address	Function Code	Address High	Address Low	Register High	Register Low	Byte Count	Data 1~2	CRC
0x01~0x1F	0x10	0x00	0x0E	0x00	0x01	0x02	0	Calculation by table look-up method

Command description:

Triggers the instrument to measure once.

7.3.6.2 Address 0x000F (Trigger Mode)

Write command:

Send Address	Function Code	Address High	Address Low	Register High	Register Low	Byte Count	Data 1~2	CRC
0x01~0x1F	0x10	0x00	0x0F	0x00	0x01	0x02	0~3	Calculation by table look-up method

Command description:

Sets the **trigger mode** of the instrument's <Measurement Settings> page.

0 indicates that the instrument is automatically triggered (INT);

1 indicates that the instrument is triggered (MAN) by pressing **TRIGGER** at the panel.

2 indicates that the instrument is triggered by HANDLER interface (EXT).

3 indicates that the instrument is triggered by RS232 communication interface (BUS).

Read command:

Send Address	Function Code	Address High	Address Low	Register High	Register Low	CRC
0x01~0x1F	0x03	0x00	0x0F	0x00	0x01	Calculation by table look-up method

Return command:

Send Address	Function Code	Byte Count	Data 1~2	CRC
0x01~0x1F	0x03	0x02	0~3	Calculation by table look-up method

Description:

Queries the **trigger mode** of the current <Measurement Settings> page of the instrument. Returns data of integer type, returning data from 0 to 3.

7.3.6.3 Address 0x0010 (Measurement Delay)

Write command:

Send Address	Function Code	Address High	Address Low	Register High	Register Low	Byte Count	Data 1 to 4	CRC
0x01~0x1F	0x10	0x00	0x10	0x00	0x02	0x04	0~9.999	Calculation by table look-up method

Command description:

Sets the **measurement delay time** on the instrument <Measurement Settings> page. The range of data 1 to 4 is from 0 to 9.999. The unit is second.

Read command:

Send Address	Function Code	Address High	Address Low	Register High	Register Low	CRC
0x01~0x1F	0x03	0x00	0x10	0x00	0x02	Calculation by table look-up method

Return command:

Send Address	Function Code	Byte Count	Data 1 to 4	CRC
0x01~0x1F	0x03	0x04	0~9.999	Calculation by table look-up method

Description:

Queries the **measurement delay** on the instrument <Measurement Settings> page. The return type is a floating-point number, and the return range is from 0 to 9.999.

7.3.6.4 Address 0x0011 (Measurement Delay Automatic)

Write command:

Send Address	Function Code	Address High	Address Low	Register High	Register Low	Byte Count	Data 1~2	CRC
0x01~0x1F	0x10	0x00	0x11	0x00	0x01	0x02	0 or 1	Calculation by table look-up method

Command description:

Sets the **measurement delay** on the instrument's <Measurement Settings> page.

0 indicates that the **measurement delay** on the <Measurement Settings> page is set to HOLD.

1 indicates that the **measurement delay** on the <Measurement Settings> page is set to AUTO.

Read command:

Send Address	Function Code	Address High	Address Low	Register High	Address Low	CRC
0x01~0x1F	0x03	0x00	0x11	0x00	0x01	Calculation by table look-up method

Return command:

Send Address	Function Code	Byte Count	Data 1~2	CRC
0x01~0x1F	0x03	0x02	0 or 1	Calculation by table look-up method

Description: Queries the measurement delay time on the <Measurement Settings> page of the instrument.

0 indicates that the current measurement delay on the <Measurement Settings> page is HOLD.

1 indicates that the current measurement delay on the <Measurement Settings> page is AUTO.

7.3.7 FETC Command Description

7.3.7.1 Address 0x0012 (Read single parameter measured value, compare OFF)

Read command:

Send Address	Function Code	Address High	Address Low	Register High	Address Low	CRC
0x01~0x1F	0x03	0x00	0x12	0x00	0x02	Calculation by table look-up method

Return command:

Send Address	Function Code	Byte Count	Data 1 to 4	CRC
0x01~0x1F	0x03	0x04	-3.4E+38~3.4E+38	Calculation by table look-up method

Description:

The measurement mode on the <System Setup> page is Alone, and the comparison under <Measurement Display> is OFF to obtain the last measurement result of the instrument.

When the measurement function is in single parameter mode (R, T), the return data format is: <Main parameter>.

<Main Parameter> range is $-3.4E+38 \sim 3.4E+38$. data 1~4 indicates <Main Parameter>. Returns $+9.90000E+37$ when the range is exceeded, or a measurement error exists.

Note: This query command returns data only when the instrument is in the <Measurement Display> page.

7.3.7.2 Address 0x0013 (Read single-parameter measured value, compare ON)

Read command:

Send Address	Function Code	Address High	Address Low	Register High	Address Low	CRC
0x01~0x1F	0x03	0x00	0x13	0x00	0x04	Calculation by table look-up method

Return command:

Send Address	Function Code	Byte Count	Data 1 to 4	Data 5~8	CRC
0x01~0x1F	0x03	0x08	$-3.4E+38 \sim 3.4E+38$	1~3	Calculation by table look-up method

Description:

Measurement mode is Alone on the <System Settings> page, and Comparison is ON under <Measurement Display> to obtain the last measurement result of the instrument and the comparison result.

When the measurement function is in single-parameter mode (R, T), the return data format is: <main parameter> <comparison result>.

<Main Parameter> range is $-3.4E+38 \sim 3.4E+38$. data 1~4 indicates <Main Parameter>. Returns $+9.90000E+37$ when the range is exceeded, or a measurement error exists.

<comparison result> ranges from 1 to 3. data 5 to 8 indicates <comparison result>.

1 indicates that the comparison result is GD; 2 indicates that the comparison result is HI; 3 indicates that the comparison result is LO.

Note: This query command returns data only when the instrument is in the <Measurement Display> page.

7.3.7.3 Address 0x0014 (Read two-parameter measured value, compare OFF)

Read command:

Send Address	Function Code	Address High	Address Low	Register High	Address Low	CRC
0x01~0x1F	0x03	0x00	0x14	0x00	0x04	Calculation by table look-up method

Return command:

Send Address	Function Code	Byte Count	Data 1 to 4	Data 5~8	CRC
0x01~0x1F	0x03	0x08	-3.4E+38~3.4E+38	-3.4E+38~3.4E+38	Calculation by table look-up method

Description:

The measurement mode on the <System Setup> page is Alone, and the comparison under <Measurement Display> is OFF, and the result of the last measurement is read.

When the measurement function is in two-parameter mode (R-T), the return data format is: <primary parameter> <secondary parameter>.

<Main Parameter> range is -3.4E+38~3.4E+38. data 1~4 indicates <Main Parameter>. Returns +9.90000E+37 when the range is exceeded, or a measurement error exists.

<Sub-parameter> range is -3.4E+38~3.4E+38. data 5~8 indicates <Sub-parameter>. Returns +9.90000E+37 when the range is exceeded, or a measurement error exists.

Note: This query command returns data only when the instrument is in the <Measurement Display> page.

7.3.7.4 Address 0x0015 (Read two-parameter measured value, compare ON)

Read command:

Send Address	Function Code	Address High	Address Low	Register High	Address Low	CRC
0x01~0x1F	0x03	0x00	0x15	0x00	0x06	Calculation by table look-up method

Return command:

Send Address	Function Code	Byte Count	Data 1 to 4	Data 5~8	Data 9 to 12	CRC
0x01~0x1F	0x03	0x0C	-3.4E+38~3.4E+38	-3.4E+38~3.4E+38	1~3	Calculation by table look-up method

Description:

Measurement mode is Alone on the <System Settings> page, and Comparison under <Measurement Display> is ON to read the result of the last measurement.

When the measurement function is in two-parameter mode (R-T), the return data format is: <primary parameter> <secondary parameter> <comparison result>.

<Main Parameter> range is -3.4E+38~3.4E+38. data 1~4 indicates <Main Parameter>. Returns +9.90000E+37 when the range is exceeded, or a measurement error exists.

<Sub-parameter> range is $-3.4E+38 \sim 3.4E+38$. data 5~8 indicates <Sub-parameter>. Returns $+9.90000E+37$ when the range is exceeded, or a measurement error exists.

<comparison result> ranges from 1 to 3. data 9 to 12 indicates <comparison result>.

1 indicates that the comparison result is GD; 2 indicates that the comparison result is HI; 3 indicates that the comparison result is LO.

Note: This query command returns data only when the instrument is in the <Measurement Display> page.

7.3.7.5 Address 0x0016 (Channel Number)

Write command:

Send Address	Function Code	Address High	Address Low	Register High	Register Low	Byte Count	Data 1~2	CRC
0x01~0x1F	0x10	0x00	0x16	0x00	0x01	0x02	1~90	Calculation by table look-up method

Command description:

Sets the channel number of the test result to be read, which is on. The range of data 1 to 2 is from 1 to 90.

7.3.7.6 Address 0x0017 (Read scanning measurement, compare OFF)

Read command:

Send Address	Function Code	Address High	Address Low	Register High	Register Low	CRC
0x01~0x1F	0x03	0x00	0x17	0x00	0x02	Calculation by table look-up method

Return command:

Send Address	Function Code	Byte Count	Data 1 to 4	CRC
0x01~0x1F	0x03	0x04	$-3.4E+38 \sim 3.4E+38$	Calculation by table look-up method

Description:

Measurement mode is Scan on the <System Setup> page, and **Comparison** under <Measurement Display> is OFF to acquire the last measurement result of the instrument.

When the measurement function is in single parameter mode (R, T), the return data format is: <Main parameter>.

<Main Parameter> The range is $-3.4E+38$ to $3.4E+38$. Returns $+9.90000E+37$ when the range is exceeded or there is a measurement error.

Note: This query command returns data only when the instrument is in the <Measurement Display> page.

7.3.7.7 Address 0x0018 (Read scanning measurement, compare ON)

Read command:

Send Address	Function Code	Address High	Address Low	Register High	Address Low	CRC
0x01~0x1F	0x03	0x00	0x18	0x00	0x04	Calculation by table look-up method

Return command:

Send Address	Function Code	Byte Count	Data 1 to 4	Data 5~8	CRC
0x01~0x1F	0x03	0x08	-3.4E+38~3.4E+38	1~3	Calculation by table look-up method

Description:

Measurement mode is Scan on the <System Settings> page, and **Compare** is ON under <Measurement Display> to acquire the last measurement result of the instrument and the comparison result.

When the measurement function is in single-parameter mode (R, T), the return data format is: <main parameter> <comparison result>.

<Main Parameter> The range is -3.4E+38 to 3.4E+38. Returns +9.90000E+37 when the range is exceeded or there is a measurement error.

<comparison results> range from 1 to 3.

1 indicates that the comparison result is GD; 2 indicates that the comparison result is HI; 3 indicates that the comparison result is LO.

Note: This query command returns data only when the instrument is in the <Measurement Display> page.

7.3.7.8 Address 0x0019 (Automatically Acquired)

Write command:

Send Address	Function Code	Address High	Address Low	Register High	Address Low	Byte Count	Data 1~2	CRC
0x01~0x1F	0x10	0x00	0x19	0x00	0x01	0x02	0 or 1	Calculation by table look-up method

Command description:

Sets whether or not the instrument automatically returns the results of each measurement.

0 means non-automatic; 1 means automatic.

Note: Use this command, see Section 7.3.1 for details.

7.3.8 TEMP Command Description

7.3.8.1 Address 0x001A (Sensor)

Write command:

Send Address	Function Code	Address High	Address Low	Register High	Register Low	Byte Count	Data 1~2	CRC
0x01~0x1F	0x10	0x00	0x1A	0x00	0x01	0x02	0~3	Calculation by table look-up method

Command description:

Sets the parameter **sensor** on the instrument's <Measurement Settings> page.

0 indicates that the setting parameter **sensor** is PT100.

1 indicates that the setting parameter **sensor** is PT500.

2 indicates that the setting parameter **sensor** is AnLG_In.

3 indicates that the setting parameter **sensor** is Termistor.

Read command:

Send Address	Function Code	Address High	Address Low	Register High	Register Low	CRC
0x01~0x1F	0x03	0x00	0x1A	0x00	0x01	Calculation by table look-up method

Return command:

Send Address	Function Code	Byte Count	Data 1~2	CRC
0x01~0x1F	0x03	0x02	0 or 1	Calculation by table look-up method

Description:

Queries the parameter **sensor** on the instrument's <Measurement Settings> page.

0 indicates that the setting parameter **sensor** is PT100.

1 indicates that the setting parameter **sensor** is PT500.

2 indicates that the setting parameter **sensor** is AnLG_In.

3 indicates that the setting parameter **sensor** is Termistor.

7.3.8.2 Address 0x001B (V1, T1, V2, T2)

Write command:

Send Address	Function Code	Address High	Address Low	Register High	Address Low	Byte Count	Data 1 to 4	Data 5~8	Data 9 to 12	Data 13-16	CRC
0x01~0x1F	0x10	0x00	0x1B	0x00	0x08	0x10	0~2.00	-99.9~999.9	0~2.00	-99.9~999.9	Calculation by table look-up method

Command description:

Sets **V1**, **T1**, **V2**, and **T2** on the instrument <Measurement Settings> page.

Data 1 to 4 is set the value of the initial resistance **V1**, the range of data 1 to 4 is from 0 to 2.00 in V.

Data 5 to 8 is set the value of the initial temperature **T1**, and the range of data 5 to 8 is from -99.9 to 999.9 in °C.

Data 9 to 12 is set the value of the constant **V2**, and the range of data 9 to 12 is from 0 to 2.00 in V.

Data 13 to 16 is set the value of the constant **T2**, and the range of data 13 to 16 is from -99.9 to 999.9 in degrees Celsius.

Read command:

Send Address	Function Code	Address High	Address Low	Register High	Address Low	CRC
0x01~0x1F	0x03	0x00	0x1B	0x00	0x08	Calculation by table look-up method

Return command:

Send Address	Function Code	Byte Count	Data 1 to 4	Data 5~8	Data 5~8	Data 9 to 12	CRC
0x01~0x1F	0x03	0x10	0~2.00	-99.9~999.9	0~2.00	-99.9~999.9	Calculation by table look-up method

Description:

Queries **V1**, **T1**, **V2**, and **T2** on the instrument <Measurement Settings> page. The return type is a floating-point number.

Data 1 to 4 are the values of the initial resistance **V1**, and the range of data 1 to 4 is from 0 to 2.00 in V.

Data 5 to 8 are the values of the initial temperature **T1**, and the range of data 5 to 8 is from -99.9 to 999.9 in degrees Celsius.

Data 9 to 12 are the values of the constant **V2**, and the range of data 9 to 12 is from 0 to 2.00 in V.

Data 13 to 16 are the values of the constant **T2**, and the range of data 13 to 16 is from -99.9 to 999.9 in °C.

7.3.8.3 Address 0x001C (Temperature Compensation)

Write command:

Send Address	Function Code	Address High	Address Low	Register High	Register Low	Byte Count	Data 1~2	CRC
0x01~0x1F	0x10	0x00	0x1C	0x00	0x01	0x02	0 or 1	Calculation by table look-up method

Command description:

Sets the parameter **Temperature Compensation** on the instrument's <Measurement Settings> page.

0 indicates parameter **temperature compensation** is OFF; 1 indicates parameter **temperature compensation** is TC.

Read command:

Send Address	Function Code	Address High	Address Low	Register High	Register Low	CRC
0x01~0x1F	0x03	0x00	0x1C	0x00	0x01	Calculation by table look-up method

Return command:

Send Address	Function Code	Byte Count	Data 1~2	CRC
0x01~0x1F	0x03	0x02	0 or 1	Calculation by table look-up method

Description:

Queries the parameter **temperature compensation** on the instrument <Measurement Settings> page.

0 indicates that the parameter **temperature compensation** is OFF; 1 indicates that the parameter **temperature compensation** is TC.

7.3.8.4 Address 0x001D (t0 and at0)

Write command:

Send Address	Function Code	Address High	Address Low	Register High	Address Low	Byte Count	Data 1 to 4	Data 5~8	CRC
0x01~0x1F	0x10	0x00	0x1D	0x00	0x02	0x04	-10~99.9	-99999~99999	Calculation by table look-up method

Command description:

Set $t0$ and $at0$ on the <Measurement Settings> page of the instrument.

Data 1~4 is set the value of $t0$, the range of data 1~4 is from -10.0 to 99.9 in °C.

Data 5~8 is set the value of $at0$, the range of data 5~8 is from -99999 to 99999 in ppm.

Read command:

Send Address	Function Code	Address High	Address Low	Register High	Address Low	CRC
0x01~0x1F	0x03	0x00	0x1D	0x00	0x02	Calculation by table look-up method

Return command:

Send Address	Function Code	Byte Count	Data 1 to 4	Data 5~8	CRC
0x01~0x1F	0x03	0x04	-10~99.9	-99999~99999	Calculation by table look-up method

Description:

Queries $t0$ and $at0$ on the instrument <Measurement Settings> page. The return type is a floating-point number.

7.3.9 COMP Command Description

7.3.9.1 Address 0x001E (Comparison Status)

Write command:

Send Address	Function Code	Address High	Address Low	Register High	Address Low	Byte Count	Data 1~2	CRC
0x01~0x1F	0x10	0x00	0x1E	0x00	0x01	0x02	0 or 1	Calculation by table look-up method

Command description:

Sets the parameter **comparison status** of the instrument's <Boundary Settings> page.

0 indicates that the parameter **comparison status** is OFF; 1 indicates that the parameter **comparison status** is ON.

Read command:

Send Address	Function Code	Address High	Address Low	Register High	Address Low	CRC
0x01~0x1F	0x03	0x00	0x1E	0x00	0x01	Calculation by table look-up method

Return command:

Send Address	Function Code	Byte Count	Data 1~2	CRC
0x01~0x1F	0x03	0x02	0 or 1	Calculation by table look-up method

Description:

Queries the parameter **comparison status** on the instrument <Boundary Settings> page.

0 indicates that the parameter **comparison status** is OFF; 1 indicates that the parameter **comparison status** is ON.

7.3.9.2 Address 0x001F (Comparison Signal)

Write command:

Send Address	Function Code	Address High	Address Low	Register High	Address Low	Byte Count	Data 1~2	CRC
0x01~0x1F	0x10	0x00	0x1F	0x00	0x01	0x02	0 or 1	Calculation by table look-up method

Command description:

Sets the **comparison signal** under Tools on the instrument <Boundary Settings> page.

0 indicates that the parameter **comparison signal** is OFF.

1 indicates that the parameter **comparison signal** is ON.

Read command:

Send Address	Function Code	Address High	Address Low	Register High	Address Low	CRC
0x01~0x1F	0x03	0x00	0x1F	0x00	0x01	Calculation by table look-up method

Return command:

Send Address	Function Code	Byte Count	Data 1~2	CRC
0x01~0x1F	0x03	0x02	0 or 1	Calculation by table look-up method

Description:

Queries the parameter **comparison signal** under Tools on the instrument <Boundary Settings> page.

0 indicates that the parameter **comparison signal** is OFF.

1 indicates that the parameter **comparison signal** is ON.

7.3.9.3 Address 0x0020 (Signal Mode)

Write command:

Send Address	Function Code	Address High	Address Low	Register High	Register Low	Byte Count	Data 1~2	CRC
0x01~0x1F	0x10	0x00	0x20	0x00	0x01	0x02	0 or 1	Calculation by table look-up method

Command description:

Sets the **signal mode** under Tools on the instrument <Boundary Settings> page.

0 indicates that the parameter **signal mode** is NG.

1 indicates that the parameter **signal mode** is GD.

Read command:

Send Address	Function Code	Address High	Address Low	Register High	Register Low	CRC
0x01~0x1F	0x03	0x00	0x20	0x00	0x01	Calculation by table look-up method

Return command:

Send Address	Function Code	Byte Count	Data 1~2	CRC
0x01~0x1F	0x03	0x02	0 or 1 or 2	Calculation by table look-up method

Description:

Queries the parameter **signal mode** under Tools on the instrument <Boundary Settings> page.

0 indicates that the parameter **signal mode** is NG.

1 indicates that the parameter **signal mode** is GD.

7.3.9.4 Address 0x0021 (Boundary Mode)

Write command:

Send Address	Function Code	Address High	Address Low	Register High	Register Low	Byte Count	Data 1~2	CRC
0x01~0x1F	0x10	0x00	0x21	0x00	0x01	0x02	0~2	Calculation by table look-up method

Command description:

Sets the parameter **boundary mode** of the instrument <Boundary Settings> page.

0 indicates that the parameter **boundary mode** is AbsDev.

1 indicates that the parameter **boundary mode** is Perc.

2 indicates that the parameter **boundary mode** is ABS.

Read command:

Send Address	Function Code	Address High	Address Low	Register High	Register Low	CRC
0x01~0x1F	0x03	0x00	0x21	0x00	0x01	Calculation by table look-up method

Return command:

Send Address	Function Code	Byte Count	Data 1~2	CRC
0x01~0x1F	0x03	0x02	0~2	Calculation by table look-up method

Description:

Queries the parameter **boundary mode** on the instrument <Boundary Settings> page.

0 indicates that the parameter **boundary mode** is AbsDev.

1 indicates that the parameter **boundary mode** is Perc.

2 indicates that the parameter **boundary mode** is ABS.

7.3.9.5 Address 0x0022 (Nominal Ω)

Write command:

Send Address	Function Code	Address High	Address Low	Register High	Register Low	Byte Count	Data 1 to 4	CRC
0x01~0x1F	0x10	0x00	0x22	0x00	0x02	0x04	0~2E+5	Calculation by table look-up method

Command description:

Sets the **nominal** of the instrument's <Boundary Settings> page. The range of data 1 to 4 is from 0 to 2E+5 in Ω .

Read command:

Send Address	Function Code	Address High	Address Low	Register High	Register Low	CRC
0x01~0x1F	0x03	0x00	0x22	0x00	0x02	Calculation by table look-up method

Return command:

Send Address	Function Code	Byte Count	Data 1 to 4	CRC
0x01~0x1F	0x03	0x04	0~2E+5	Calculation by table look-up method

Description:

Queries the **nominal** of the instrument <Boundary Settings> page. The return type is a floating-point number, and the return range is from 0 to 2E+5.

Note: This command only applies to the <System Setup> page where the **measurement mode is Alone**, the <Measurement Setup> page where the **measurement parameter is R or R-T**, and the <Boundary Setup> page where the **boundary mode is ABS or AbsDev**.

7.3.9.6 Address 0x0023 (AbsDev Upper Limit)

Write command:

Send Address	Function Code	Address High	Address Low	Register High	Register Low	Byte Count	Data 1 to 4	CRC
0x01~0x1F	0x10	0x00	0x23	0x00	0x02	0x04	0~2E+5	Calculation by table look-up method

Command description:

Sets the **upper limit of the instrument** <Boundary Setting> page. The range of data 1 to 4 is from 0 to 2E+5 in Ω .

Read command:

Send Address	Function Code	Address High	Address Low	Register High	Address Low	CRC
0x01~0x1F	0x03	0x00	0x23	0x00	0x02	Calculation by table look-up method

Return command:

Send Address	Function Code	Byte Count	Data 1 to 4	CRC
0x01~0x1F	0x03	0x04	0~2E+5	Calculation by table look-up method

Description:

Queries the **upper limit** of the instrument <Boundary Settings> page. The return type is a floating-point number, and the return range is from 0 to 2E+5.

Note: This command only applies to the <System Setup> page where the measurement mode is Alone, the <Measurement Setup> page where the measurement parameter is R or R-T, and the <Boundary Setup> page where the boundary mode is AbsDev.

7.3.9.7 Address 0x0024 (AbsDev Lower Limit)

Write command:

Send Address	Function Code	Address High	Address Low	Register High	Address Low	Byte Count	Data 1 to 4	CRC
0x01~0x1F	0x10	0x00	0x24	0x00	0x02	0x04	0~2E+5	Calculation by table look-up method

Command description:

Sets the **lower limit** of the instrument's <Boundary Setting> page. The range of data 1 to 4 is from 0 to 2E+5 in Ω .

Read command:

Send Address	Function Code	Address High	Address Low	Register High	Address Low	CRC
0x01~0x1F	0x03	0x00	0x24	0x00	0x02	Calculation by table look-up method

Return command:

Send Address	Function Code	Byte Count	Data 1 to 4	CRC
0x01~0x1F	0x03	0x04	0~2E+5	Calculation by table look-up method

Description:

Queries the **lower limit** of the instrument <Boundary Settings> page. The return type is a floating-point number, and the return range is from 0 to 2E+5.

Note: This command only applies to the <System Setup> page where the **measurement mode is Alone**, the <Measurement Setup> page where the **measurement parameter is R or R-T**, and the <Boundary Setup> page where the **boundary mode is AbsDev**.

7.3.9.8 Address 0x0025 (Perc Upper Limit)

Write command:

Send Address	Function Code	Address High	Address Low	Register High	Address Low	Byte Count	Data 1 to 4	CRC
0x01~0x1F	0x10	0x00	0x25	0x00	0x02	0x04	-99.99~99.99	Calculation by table look-up method

Command description:

Sets the **upper limit of the instrument's** <Boundary Settings> page. The range of data 1 to 4 is from -99.99 to 99.99 in %.

Read command:

Send Address	Function Code	Address High	Address Low	Register High	Address Low	CRC
0x01~0x1F	0x03	0x00	0x25	0x00	0x02	Calculation by table look-up method

Return command:

Send Address	Function Code	Byte Count	Data 1 to 4	CRC
0x01~0x1F	0x03	0x04	-99.99~99.99	Calculation by table look-up method

Description:

Queries the **upper limit** of the instrument <Boundary Settings> page. The return type is a floating-point number, and the return range is from -99.99 to 99.99 in %.

Note: This command only applies to the <System Setup> page where the measurement mode is Alone, the <Measurement Setup> page where the measurement parameter is R or R-T, and the <Boundary Setup> page where the boundary mode is Perc.

7.3.9.9 Address 0x0026 (Perc Lower Limit)

Write command:

Send Address	Function Code	Address High	Address Low	Register High	Register Low	Byte Count	Data 1 to 4	CRC
0x01~0x1F	0x10	0x00	0x26	0x00	0x02	0x04	-99.99~99.99	Calculation by table look-up method

Command description:

Sets the lower limit of the instrument's <Boundary Settings> page. The range of data 1 to 4 is from -99.99 to 99.99 in %.

Read command:

Send Address	Function Code	Address High	Address Low	Register High	Register Low	CRC
0x01~0x1F	0x03	0x00	0x26	0x00	0x02	Calculation by table look-up method

Return command:

Send Address	Function Code	Byte Count	Data 1 to 4	CRC
0x01~0x1F	0x03	0x04	-99.99~99.99	Calculation by table look-up method

Description:

Queries the lower limit of the instrument <Boundary Settings> page. The return type is a floating-point number, and the return range is from -99.99 to 99.99 in %.

Note: This command only applies to the <System Setup> page where the measurement mode is Alone, the <Measurement Setup> page where the measurement parameter is R or R-T, and the <Boundary Setup> page where the boundary mode is Perc.

7.3.9.10 Address 0x0027 (ABS Upper Limit)

Write command:

Send Address	Function Code	Address High	Address Low	Register High	Address Low	Byte Count	Data 1 to 4	CRC
0x01~0x1F	0x10	0x00	0x27	0x00	0x02	0x04	0~2E+5	Calculation by table look-up method

Command description:

Sets the **upper limit of the instrument** <Boundary Setting> page. The range of data 1 to 4 is from 0 to 2E+5. unit is Ω .

Read command:

Send Address	Function Code	Address High	Address Low	Register High	Address Low	CRC
0x01~0x1F	0x03	0x00	0x27	0x00	0x02	Calculation by table look-up method

Return command:

Send Address	Function Code	Byte Count	Data 1 to 4	CRC
0x01~0x1F	0x03	0x04	0~2E+5	Calculation by table look-up method

Description:

Queries the **upper limit** of the instrument <Boundary Settings> page. The return type is a floating-point number, and the return range is from 0 to 2E+5.

Note: This command is only applicable to the <System Setup> page where the **measurement mode is Alone**, the <Measurement Setup> page where the **measurement parameter is R or R-T**, and the <Boundary Setup> page where the **boundary mode is ABS**.

7.3.9.11 Address 0x0028 (ABS Lower Limit)

Write command:

Send Address	Function Code	Address High	Address Low	Register High	Address Low	Byte Count	Data 1 to 4	CRC
0x01~0x1F	0x10	0x00	0x28	0x00	0x02	0x04	0~2E+5	Calculation by table look-up method

Command description:

Sets the **lower limit** of the instrument's <Boundary Setting> page. The range of data 1 to 4 is from 0 to 2E+5 in Ω .

Read command:

Send Address	Function Code	Address High	Address Low	Register High	Address Low	CRC
0x01~0x1F	0x03	0x00	0x28	0x00	0x02	Calculation by table look-up method

Return command:

Send Address	Function Code	Byte Count	Data 1 to 4	CRC
0x01~0x1F	0x03	0x04	0~2E+5	Calculation by table look-up method

Description:

Queries the **lower limit** of the instrument <Boundary Settings> page. The return type is a floating-point number, and the return range is from 0 to 2E+5.

Note: This command is only applicable to the <System Setup> page where the **measurement mode is Alone**, the <Measurement Setup> page where the **measurement parameter is R or R-T**, and the <Boundary Setup> page where the **boundary mode is ABS**.

7.3.9.12 Address 0x0029 (Nominal °C)

Write command:

Send Address	Function Code	Address High	Address Low	Register High	Address Low	Byte Count	Data 1 to 4	CRC
0x01~0x1F	0x10	0x00	0x29	0x00	0x02	0x04	-100~999.9	Calculation by table look-up method

Command description:

Sets the **nominal** on the instrument <Boundary Setup> page. The range of data 1 to 4 is from -100 to 999.9 in °C.

Read command:

Send Address	Function Code	Address High	Address Low	Register High	Address Low	CRC
0x01~0x1F	0x03	0x00	0x29	0x00	0x02	Calculation by table look-up method

Return command:

Send Address	Function Code	Byte Count	Data 1 to 4	CRC
0x01~0x1F	0x03	0x04	-100~999.9	Calculation by table look-up method

Description:

Queries the **nominal** of the instrument <Boundary Settings> page. The return type is a floating-point number, and the return range is from -100 to 999.9 in °C.

Note: This command is only applicable to the <System Setup> page where the measurement mode is Alone, the <Measurement Setup> page where the measurement parameter is T, and the <Boundary Setup> page where the boundary mode is ABS or AbsDev.

7.3.9.13 Address 0x002A (AbsDev Upper Limit)

Write command:

Send Address	Function Code	Address High	Address Low	Register High	Address Low	Byte Count	Data 1 to 4	CRC
0x01~0x1F	0x10	0x00	0x2A	0x00	0x02	0x04	-100~999.9	Calculation by table look-up method

Command description:

Sets the **upper limit of the instrument's** <Boundary Settings> page. The range of data 1 to 4 is from -100 to 999.9 in °C.

Read command:

Send Address	Function Code	Address High	Address Low	Register High	Address Low	CRC
0x01~0x1F	0x03	0x00	0x2A	0x00	0x02	Calculation by table look-up method

Return command:

Send Address	Function Code	Byte Count	Data 1 to 4	CRC
0x01~0x1F	0x03	0x04	-100~999.9	Calculation by table look-up method

Description:

Queries the **upper limit** of the instrument <Boundary Settings> page. The return type is a floating-point number, and the return range is from -100 to 999.9 in °C.

Note: This command only applies to the <System Setup> page with measurement mode Alone, the <Measurement Setup> page with measurement parameter T, and the <Boundary Setup> page with boundary mode AbsDev.

7.3.9.14 Address 0x002B (AbsDev Lower Limit)

Write command:

Send Address	Function Code	Address High	Address Low	Register High	Register Low	Byte Count	Data 1 to 4	CRC
0x01~0x1F	0x10	0x00	0x2B	0x00	0x02	0x04	-100~999.9	Calculation by table look-up method

Command description:

Sets the lower limit of the instrument's <Boundary Settings> page. The range of data 1 to 4 is from -100 to 999.9 in °C.

Read command:

Send Address	Function Code	Address High	Address Low	Register High	Register Low	CRC
0x01~0x1F	0x03	0x00	0x2B	0x00	0x02	Calculation by table look-up method

Return command:

Send Address	Function Code	Byte Count	Data 1 to 4	CRC
0x01~0x1F	0x03	0x04	-100~999.9	Calculation by table look-up method

Description:

Queries the lower limit of the instrument <Boundary Settings> page. The return type is a floating-point number, and the return range is from -100 to 999.9 in °C.

Note: This command only applies to the <System Setup> page with measurement mode Alone, the <Measurement Setup> page with measurement parameter T, and the <Boundary Setup> page with boundary mode AbsDev.

7.3.9.15 Address 0x002C (Perc Upper Limit)

Write command:

Send Address	Function Code	Address High	Address Low	Register High	Address Low	Byte Count	Data 1 to 4	CRC
0x01~0x1F	0x10	0x00	0x2C	0x00	0x02	0x04	-99.99~99.99	Calculation by table look-up method

Command description:

Sets the upper limit of the instrument's <Boundary Settings> page. The range of data 1 to 4 is from -99.99 to 99.99 in %.

Read command:

Send Address	Function Code	Address High	Address Low	Register High	Address Low	CRC
0x01~0x1F	0x03	0x00	0x2C	0x00	0x02	Calculation by table look-up method

Return command:

Send Address	Function Code	Byte Count	Data 1 to 4	CRC
0x01~0x1F	0x03	0x04	-99.99~99.99	Calculation by table look-up method

Description:

Queries the upper limit of the instrument <Boundary Settings> page. The return type is a floating-point number, and the return range is from -99.99 to 99.99 in %.

Note: This command only applies to the <System Setup> page where the measurement mode is Alone, the <Measurement Setup> page where the measurement parameter is T, and the <Boundary Setup> page where the boundary mode is Perc.

7.3.9.16 Address 0x002D (Perc Lower Limit)

Write command:

Send Address	Function Code	Address High	Address Low	Register High	Address Low	Byte Count	Data 1 to 4	CRC
0x01~0x1F	0x10	0x00	0x2D	0x00	0x02	0x04	-99.99~99.99	Calculation by table look-up method

Command description:

Sets the lower limit of the instrument's <Boundary Settings> page. The range of data 1 to 4 is from -99.99 to 99.99 in %.

Read command:

Send Address	Function Code	Address High	Address Low	Register High	Address Low	CRC
0x01~0x1F	0x03	0x00	0x2D	0x00	0x02	Calculation by table look-up method

Return command:

Send Address	Function Code	Byte Count	Data 1 to 4	CRC
0x01~0x1F	0x03	0x04	-99.99~99.99	Calculation by table look-up method

Description:

Queries the lower limit of the instrument <Boundary Settings> page. The return type is a floating-point number, and the return range is from -99.99 to 99.99 in %.

Note: This command only applies to the <System Setup> page where the measurement mode is Alone, the <Measurement Setup> page where the measurement parameter is T, and the <Boundary Setup> page where the boundary mode is Perc.

7.3.9.17 Address 0x002E (ABS Upper Limit)

Write command:

Send Address	Function Code	Address High	Address Low	Register High	Address Low	Byte Count	Data 1 to 4	CRC
0x01~0x1F	0x10	0x00	0x2E	0x00	0x02	0x04	-100~999.9	Calculation by table look-up method

Command description:

Sets the upper limit of the instrument's <Boundary Settings> page. The range of data 1 to 4 is from -100 to 999.9 in °C.

Read command:

Send Address	Function Code	Address High	Address Low	Register High	Address Low	CRC
0x01~0x1F	0x03	0x00	0x2E	0x00	0x02	Calculation by table look-up method

Return command:

Send Address	Function Code	Byte Count	Data 1 to 4	CRC
0x01~0x1F	0x03	0x04	-100~999.9	Calculation by table look-up method

Description: Queries the upper limit of the instrument <Boundary Setting> page. The return type is a floating-point number, and the return range is from -100 to 999.9 in °C.

Note: This command is only applicable to the <System Setup> page where the measurement mode is Alone, the <Measurement Setup> page where the measurement parameter is T, and the <Boundary Setup> page where the boundary mode is ABS.

7.3.9.18 Address 0x002F (ABS Lower Limit)

Write command:

Send Address	Function Code	Address High	Address Low	Register High	Address Low	Byte Count	Data 1 to 4	CRC
0x01~0x1F	0x10	0x00	0x2F	0x00	0x02	0x04	-100~999.9	Calculation by table look-up method

Command description:

Sets the lower limit of the instrument's <Boundary Settings> page. The range of data 1 to 4 is from -100 to 999.9 in °C.

Read command:

Send Address	Function Code	Address High	Address Low	Register High	Address Low	CRC
0x01~0x1F	0x03	0x00	0x2F	0x00	0x02	Calculation by table look-up method

Return command:

Send Address	Function Code	Byte Count	Data 1 to 4	CRC
0x01~0x1F	0x03	0x04	-100~999.9	Calculation by table look-up method

Description: Queries the lower limit of the instrument <Boundary Setting> page. The return type is a floating-point number, and the return range is from -100 to 999.9 in °C.

Note: This command is only applicable to the <System Setup> page where the measurement mode is Alone, the <Measurement Setup> page where the measurement parameter is T, and the <Boundary Setup> page where the boundary mode is ABS.

7.3.10 CHAN Command Description

7.3.10.1 Address 0x0030 (Channel n)

Write command:

Send Address	Function Code	Address High	Address Low	Register High	Address Low	Byte Count	Data 1~2	CRC
0x01~0x1F	0x10	0x00	0x30	0x00	0x01	0x02	1~90	Calculation by table look-up method

Command description:

Sets the channel n to be operated in scan test mode. The range of channel n is 1 to 90.

7.3.10.2 Address 0x0031 (Channel State)

Write command:

Send Address	Function Code	Address High	Address Low	Register High	Address Low	Byte Count	Data 1~2	CRC
0x01~0x1F	0x10	0x00	0x31	0x00	0x01	0x02	0 or 1	Calculation by table look-up method

Command description:

Sets the channel status of channel n on the instrument's <Channel Setup> page. Channel n is set by command 7.3.10.1.

0 indicates that the channel state of channel n is OFF.

1 indicates that the channel state of channel n is ON.

Read command:

Send Address	Function Code	Address High	Address Low	Register High	Address Low	CRC
0x01~0x1F	0x03	0x00	0x31	0x00	0x01	Calculation by table look-up method

Return command:

Send Address	Function Code	Byte Count	Data 1~2	CRC
0x01~0x1F	0x03	0x02	0 or 1	Calculation by table look-up method

Description:

Queries the channel state of channel n on the instrument <Channel Settings> page.

0 indicates that the channel state of channel n is OFF.

1 indicates that the channel state of channel n is ON.

7.3.10.3 Address 0x0032 (Test Unit, High-end, Low-end)

Write command:

Send Address	Function Code	Address High	Address Low	Register High	Address Low	Byte Count	Data 1 to 4	Data 5~8	Data 9 to 12	CRC
0x01~0x1F	0x10	0x00	0x32	0x00	0x06	0x0C	1~6	1~16	1~16	Calculation by table look-up method

Command description:

Sets the test unit, test high-end, and test low-end for channel n on the instrument <Channel Setup> page. Channel n is set by command 7.3.10.1.

Data 1 to 4 are set for the test unit, and the range of data 1 to 4 is from 1 to 6.

Data 5 to 8 are set for the test high-end, and range of data 5 to 8 is from 1 to 16.

Data 9 to 12 are set for the test low-end, and range of data 9 to 12 is from 1 to 16.

Read command:

Send Address	Function Code	Address High	Address Low	Register High	Address Low	CRC
0x01~0x1F	0x03	0x00	0x32	0x00	0x06	Calculation by table look-up method

Return command:

Send Address	Function Code	Byte Count	Data 1 to 4	Data 5~8	Data 9~12	CRC
0x01~0x1F	0x03	0x0C	1~6	1~16	1~16	Calculation by table look-up method

Description:

Queries the test unit, test high-end, and test low-end of channel n on the instrument <Channel Setup> page. Channel n is set by command 7.3.10.1.

Data 1 to 4 are set for the test unit, and the range of data 1 to 4 is from 1 to 6.

Data 5 to 8 are set for the test high-end, and the range of data 5 to 8 is from 1 to 16.

Data 9 to 12 are set for the test low-end, and the range of data 9 to 12 is from 1 to 16.

7.3.10.4 Address 0x0033 (Nominal Ω)

Write command:

Send Address	Function Code	Address High	Address Low	Register High	Address Low	Byte Count	Data 1 to 4	CRC
0x01~0x1F	0x10	0x00	0x33	0x00	0x02	0x04	0~2E+5	Calculation by table look-up method

Command description:

Sets the **nominal** of the instrument's <Boundary Settings> page. The range of data 1 to 4 is from 0 to 2E+5 in Ω .

Read command:

Send Address	Function Code	Address High	Address Low	Register High	Address Low	CRC
0x01~0x1F	0x03	0x00	0x33	0x00	0x02	Calculation by table look-up method

Return command:

Send Address	Function Code	Byte Count	Data 1 to 4	CRC
0x01~0x1F	0x03	0x04	0~2E+5	Calculation by table look-up method

Description:

Queries the **nominal** of the instrument <Boundary Settings> page. The return type is a floating-point number, and the return range is from 0 to 2E+5.

Note: This command is only applicable to the <System Setup> page where the measurement mode is Scan, the <Measurement Setup> page where the measurement parameter is R or R-T, and the <Boundary Setup> page where the boundary mode is ABS or AbsDev.

7.3.10.5 Address 0x0034 (AbsDev Upper Limit)

Write command:

Send Address	Function Code	Address High	Address Low	Register High	Address Low	Byte Count	Data 1 to 4	CRC
0x01~0x1F	0x10	0x00	0x34	0x00	0x02	0x04	0~2E+5	Calculation by table look-up method

Command description:

Sets the upper limit of the instrument's <Boundary Setting> page. The range of data 1 to 4 is from 0 to $2E+5$ in Ω .

Read command:

Send Address	Function Code	Address High	Address Low	Register High	Address Low	CRC
0x01~0x1F	0x03	0x00	0x23	0x00	0x02	Calculation by table look-up method

Return command:

Send Address	Function Code	Byte Count	Data 1 to 4	CRC
0x01~0x1F	0x03	0x04	0~ $2E+5$	Calculation by table look-up method

Description:

Queries the upper limit of the instrument <Boundary Settings> page. The return type is a floating-point number, and the return range is from 0 to $2E+5$.

Note: This command only applies to the <System Setup> page where the measurement mode is Scan, the <Measurement Setup> page where the measurement parameter is R or R-T, and the <Boundary Setup> page where the boundary mode is AbsDev.

7.3.10.6 Address 0x0035 (AbsDev Lower Limit)

Write command:

Send Address	Function Code	Address High	Address Low	Register High	Address Low	Byte Count	Data 1 to 4	CRC
0x01~0x1F	0x10	0x00	0x35	0x00	0x02	0x04	0~ $2E+5$	Calculation by table look-up method

Command description:

Sets the lower limit of the instrument's <Boundary Setting> page. The range of data 1 to 4 is from 0 to $2E+5$ in Ω .

Read command:

Send Address	Function Code	Address High	Address Low	Register High	Address Low	CRC
0x01~0x1F	0x03	0x00	0x35	0x00	0x02	Calculation by table look-up method

Return command:

Send Address	Function Code	Byte Count	Data 1 to 4	CRC
0x01~0x1F	0x03	0x04	0~2E+5	Calculation by table look-up method

Description:

Queries the **lower limit** of the instrument <Boundary Settings> page. The return type is a floating-point number, and the return range is from 0 to 2E+5.

Note: This command only applies to the <System Setup> page where the **measurement mode is Scan**, the <Measurement Setup> page where the **measurement parameter is R or R-T**, and the <Boundary Setup> page where the **boundary mode is AbsDev**.

7.3.10.7 Address 0x0036 (Perc Upper Limit)

Write command:

Send Address	Function Code	Address High	Address Low	Register High	Register Low	Byte Count	Data 1 to 4	CRC
0x01~0x1F	0x10	0x00	0x25	0x00	0x02	0x04	-99.99~99.99	Calculation by table look-up method

Command description:

Sets the **upper limit of the instrument's** <Boundary Settings> page. The range of data 1 to 4 is from -99.99 to 99.99 in %.

Read command:

Send Address	Function Code	Address High	Address Low	Register High	Register Low	CRC
0x01~0x1F	0x03	0x00	0x36	0x00	0x02	Calculation by table look-up method

Return command:

Send Address	Function Code	Byte Count	Data 1 to 4	CRC
0x01~0x1F	0x03	0x04	-99.99~99.99	Calculation by table look-up method

Description:

Queries the **upper limit** of the instrument <Boundary Settings> page. The return type is a floating-point number, and the return range is from -99.99 to 99.99 in %.

Note: This command is only applicable to the <System Setup> page where the measurement mode is Scan, the <Measurement Setup> page where the measurement parameter is R or R-T, and the <Boundary Setup> page where the boundary mode is Perc.

7.3.10.8 Address 0x0037 (Perc Lower Limit)

Write command:

Send Address	Function Code	Address High	Address Low	Register High	Register Low	Byte Count	Data 1 to 4	CRC
0x01~0x1F	0x10	0x00	0x37	0x00	0x02	0x04	-99.99~99.99	Calculation by table look-up method

Command description:

Sets the lower limit of the instrument's <Boundary Settings> page. The range of data 1 to 4 is from -99.99 to 99.99 in %.

Read command:

Send Address	Function Code	Address High	Address Low	Register High	Register Low	CRC
0x01~0x1F	0x03	0x00	0x37	0x00	0x02	Calculation by table look-up method

Return command:

Send Address	Function Code	Byte Count	Data 1 to 4	CRC
0x01~0x1F	0x03	0x04	-99.99~99.99	Calculation by table look-up method

Description:

Queries the lower limit of the instrument <Boundary Settings> page. The return type is a floating-point number, and the return range is from -99.99 to 99.99 in %.

Note: This command is only applicable to the <System Setup> page where the measurement mode is Scan, the <Measurement Setup> page where the measurement parameter is R or R-T, and the <Boundary Setup> page where the boundary mode is Perc.

7.3.10.9 Address 0x0038 (ABS Upper Limit)

Write command:

Send Address	Function Code	Address High	Address Low	Register High	Address Low	Byte Count	Data 1 to 4	CRC
0x01~0x1F	0x10	0x00	0x38	0x00	0x02	0x04	0~2E+5	Calculation by table look-up method

Command description:

Sets the upper limit of the instrument <Boundary Setting> page. The range of data 1 to 4 is from 0 to 2E+5 in Ω .

Read command:

Send Address	Function Code	Address High	Address Low	Register High	Address Low	CRC
0x01~0x1F	0x03	0x00	0x38	0x00	0x02	Calculation by table look-up method

Return command:

Send Address	Function Code	Byte Count	Data 1 to 4	CRC
0x01~0x1F	0x03	0x04	0~2E+5	Calculation by table look-up method

Description:

Queries the upper limit of the instrument <Boundary Settings> page. The return type is a floating-point number, and the return range is from 0 to 2E+5.

Note: This command is only applicable when the measurement mode is Scan on the <System Setup> page, the measurement parameter is R or R-T on the <Measurement Setup> page, and the boundary mode is ABS on the <Boundary Setup> page.

7.3.10.10 Address 0x0039 (ABS Lower Limit)

Write command:

Send Address	Function Code	Address High	Address Low	Register High	Address Low	Byte Count	Data 1 to 4	CRC
0x01~0x1F	0x10	0x00	0x39	0x00	0x02	0x04	0~2E+5	Calculation by table look-up method

Command description:

Sets the lower limit of the instrument's <Boundary Setting> page. The range of data 1 to 4 is from 0 to 2E+5 in Ω .

Read command:

Send Address	Function Code	Address High	Address Low	Register High	Address Low	CRC
0x01~0x1F	0x03	0x00	0x39	0x00	0x02	Calculation by table look-up method

Return command:

Send Address	Function Code	Byte Count	Data 1 to 4	CRC
0x01~0x1F	0x03	0x04	0~2E+5	Calculation by table look-up method

Description:

Queries the **lower limit** of the instrument <Boundary Settings> page. The return type is a floating-point number, and the return range is from 0 to 2E+5.

Note: This command is only applicable when the **measurement mode is Scan on the <System Setup> page, the **measurement parameter** is R or R-T on the <Measurement Setup> page, and the **boundary mode** is ABS on the <Boundary Setup> page.**

7.3.10.11 Address 0x003A (Nominal °C)

Write command:

Send Address	Function Code	Address High	Address Low	Register High	Address Low	Byte Count	Data 1 to 4	CRC
0x01~0x1F	0x10	0x00	0x3A	0x00	0x02	0x04	-100~999.9	Calculation by table look-up method

Command description:

Sets the **nominal** on the instrument <Boundary Setup> page. The range of data 1 to 4 is from -100 to 999.9 in °C.

Read command:

Send Address	Function Code	Address High	Address Low	Register High	Address Low	CRC
0x01~0x1F	0x03	0x00	0x3A	0x00	0x02	Calculation by table look-up method

Return command:

Send Address	Function Code	Byte Count	Data 1 to 4	CRC
0x01~0x1F	0x03	0x04	-100~999.9	Calculation by table look-up method

Description:

Queries the **nominal** of the instrument <Boundary Settings> page. The return type is a floating-point number, and the return range is from -100 to 999.9 in °C.

Note: This command only applies to the <System Setup> page where the **measurement mode** is Scan, the <Measurement Setup> page where the **measurement parameter** is T, and the <Boundary Setup> page where the **boundary mode** is ABS or AbsDev.

7.3.10.12 Address 0x003B (AbsDev Upper Limit)

Write command:

Send Address	Function Code	Address High	Address Low	Register High	Register Low	Byte Count	Data 1 to 4	CRC
0x01~0x1F	0x10	0x00	0x3B	0x00	0x02	0x04	-100~999.9	Calculation by table look-up method

Command description:

Sets the **upper limit of the instrument's** <Boundary Settings> page. The range of data 1 to 4 is from -100 to 999.9 in °C.

Read command:

Send Address	Function Code	Address High	Address Low	Register High	Register Low	CRC
0x01~0x1F	0x03	0x00	0x3B	0x00	0x02	Calculation by table look-up method

Return command:

Send Address	Function Code	Byte Count	Data 1 to 4	CRC
0x01~0x1F	0x03	0x04	-100~999.9	Calculation by table look-up method

Description:

Queries the **upper limit** of the instrument <Boundary Settings> page. The return type is a floating-point number, and the return range is from -100 to 999.9 in °C.

Note: This command only applies to the <System Setup> page where the measurement mode is Scan, the <Measurement Setup> page where the measurement parameter is T, and the <Boundary Setup> page where the boundary mode is AbsDev.

7.3.10.13 Address 0x003C (AbsDev Lower Limit)

Write command:

Send Address	Function Code	Address High	Address Low	Register High	Register Low	Byte Count	Data 1 to 4	CRC
0x01~0x1F	0x10	0x00	0x3C	0x00	0x02	0x04	-100~999.9	Calculation by table look-up method

Command description:

Sets the lower limit of the instrument's <Boundary Settings> page. The range of data 1 to 4 is from -100 to 999.9 in °C.

Read command:

Send Address	Function Code	Address High	Address Low	Register High	Register Low	CRC
0x01~0x1F	0x03	0x00	0x3C	0x00	0x02	Calculation by table look-up method

Return command:

Send Address	Function Code	Byte Count	Data 1 to 4	CRC
0x01~0x1F	0x03	0x04	-100~999.9	Calculation by table look-up method

Description:

Queries the lower limit of the instrument <Boundary Settings> page. The return type is a floating-point number, and the return range is from -100 to 999.9 in °C.

Note: This command only applies to the <System Setup> page where the measurement mode is Scan, the <Measurement Setup> page where the measurement parameter is T, and the <Boundary Setup> page where the boundary mode is AbsDev.

7.3.10.14 Address 0x003D (Perc Upper Limit)

Write command:

Send Address	Function Code	Address High	Address Low	Register High	Address Low	Byte Count	Data 1 to 4	CRC
0x01~0x1F	0x10	0x00	0x3D	0x00	0x02	0x04	-99.99~99.99	Calculation by table look-up method

Command description:

Sets the upper limit of the instrument's <Boundary Settings> page. The range of data 1 to 4 is from -99.99 to 99.99 in %.

Read command:

Send Address	Function Code	Address High	Address Low	Register High	Address Low	CRC
0x01~0x1F	0x03	0x00	0x3D	0x00	0x02	Calculation by table look-up method

Return command:

Send Address	Function Code	Byte Count	Data 1 to 4	CRC
0x01~0x1F	0x03	0x04	-99.99~99.99	Calculation by table look-up method

Description:

Queries the upper limit of the instrument <Boundary Settings> page. The return type is a floating-point number, and the return range is from -99.99 to 99.99 in %.

Note: This command is only applicable to the <System Setup> page where the measurement mode is Scan, the <Measurement Setup> page where the measurement parameter is T, and the <Boundary Setup> page where the boundary mode is Perc.

7.3.10.15 Address 0x003E (Perc Lower Limit)

Write command:

Send Address	Function Code	Address High	Address Low	Register High	Address Low	Byte Count	Data 1 to 4	CRC
0x01~0x1F	0x10	0x00	0x3E	0x00	0x02	0x04	-99.99~99.99	Calculation by table look-up method

Command description:

Sets the lower limit of the instrument's <Boundary Settings> page. The range of data 1 to 4 is from -99.99 to 99.99 in %.

Read command:

Send Address	Function Code	Address High	Address Low	Register High	Address Low	CRC
0x01~0x1F	0x03	0x00	0x3E	0x00	0x02	Calculation by table look-up method

Return command:

Send Address	Function Code	Byte Count	Data 1 to 4	CRC
0x01~0x1F	0x03	0x04	-99.99~99.99	Calculation by table look-up method

Description:

Queries the lower limit of the instrument <Boundary Settings> page. The return type is a floating-point number, and the return range is from -99.99 to 99.99 in %.

Note: This command is only applicable to the <System Setup> page where the measurement mode is Scan, the <Measurement Setup> page where the measurement parameter is T, and the <Boundary Setup> page where the boundary mode is Perc.

7.3.10.16 Address 0x003F (ABS Upper Limit)

Write command:

Send Address	Function Code	Address High	Address Low	Register High	Address Low	Byte Count	Data 1 to 4	CRC
0x01~0x1F	0x10	0x00	0x3F	0x00	0x02	0x04	-100~999.9	Calculation by table look-up method

Command description:

Sets the upper limit of the instrument's <Boundary Settings> page. The range of data 1 to 4 is from -100 to 999.9 in °C.

Read command:

Send Address	Function Code	Address High	Address Low	Register High	Address Low	CRC
0x01~0x1F	0x03	0x00	0x3F	0x00	0x02	Calculation by table look-up method

Return command:

Send Address	Function Code	Byte Count	Data 1 to 4	CRC
0x01~0x1F	0x03	0x04	-100~999.9	Calculation by table look-up method

Description: Queries the upper limit of the instrument <Boundary Setting> page. The return type is a floating-point number, and the return range is from -100 to 999.9 in °C.

Note: This command is only applicable when the measurement mode is Scan on the <System Setup> page, the measurement parameter is T on the <Measurement Setup> page, and the boundary mode is ABS on the <Boundary Setup> page.

7.3.10.17 Address 0x0040 (ABS Lower Limit)

Write command:

Send Address	Function Code	Address High	Address Low	Register High	Address Low	Byte Count	Data 1 to 4	CRC
0x01~0x1F	0x10	0x00	0x40	0x00	0x02	0x04	-100~999.9	Calculation by table look-up method

Command description:

Sets the lower limit of the instrument's <Boundary Settings> page. The range of data 1 to 4 is from -100 to 999.9 in °C.

Read command:

Send Address	Function Code	Address High	Address Low	Register High	Address Low	CRC
0x01~0x1F	0x03	0x00	0x40	0x00	0x02	Calculation by table look-up method

Return command:

Send Address	Function Code	Byte Count	Data 1 to 4	CRC
0x01~0x1F	0x03	0x04	-100~999.9	Calculation by table look-up method

Description: Queries the lower limit of the instrument <Boundary Setting> page. The return type is a floating-point number, and the return range is from -100 to 999.9 in °C.

Note: This command is only applicable when the measurement mode is Scan on the <System Setup> page, the measurement parameter is T on the <Measurement Setup> page, and the boundary mode is ABS on the <Boundary Setup> page.

7.3.11 SYST Command Description

7.3.11.1 Address 0x0041 (Touch Tone)

Write command:

Send Address	Function Code	Address High	Address Low	Register High	Register Low	Byte Count	Data 1~2	CRC
0x01~0x1F	0x10	0x00	0x41	0x00	0x01	0x02	0 or 1	Calculation by table look-up method

Command description:

Sets the touch tone for the instrument's <System Settings> page.

0 indicates that the touch tone of the <System Settings> page is OFF.

1 indicates that the touch tone of the <System Settings> page is ON.

Read command:

Send Address	Function Code	Address High	Address Low	Register High	Register Low	CRC
0x01~0x1F	0x03	0x00	0x41	0x00	0x01	Calculation by table look-up method

Return command:

Send Address	Function Code	Byte Count	Data 1~2	CRC
0x01~0x1F	0x03	0x02	0 or 1	Calculation by table look-up method

Description: Queries the touch tone on the <System Settings> page of the instrument.

0 indicates that the touch tone of the <System Settings> page is OFF.

1 indicates that the touch tone of the <System Settings> page is ON.

7.3.11.2 Address 0x0042 (Measurement Mode)

Write command:

Send Address	Function Code	Address High	Address Low	Register High	Register Low	Byte Count	Data 1~2	CRC
0x01~0x1F	0x10	0x00	0x42	0x00	0x01	0x02	0 or 1	Calculation by table look-up method

Command description:

Sets the **measurement mode** on the instrument's <System Settings> page.

0 indicates that the **measurement mode** on the <System Settings> page is Alone.

1 indicates that the **measurement mode** on the <System Settings> page is Scan.

Read command:

Send Address	Function Code	Address High	Address Low	Register High	Address Low	CRC
0x01~0x1F	0x03	0x00	0x42	0x00	0x01	Calculation by table look-up method

Return command:

Send Address	Function Code	Byte Count	Data 1~2	CRC
0x01~0x1F	0x03	0x02	0 or 1	Calculation by table look-up method

Description:

Queries the **measurement mode** on the instrument's <System Settings> page.

0 indicates that the **measurement mode** on the <System Settings> page is Alone.

1 indicates that the **measurement mode** on the <System Settings> page is Scan.

7.3.11.3 Address 0x0043 (Shift Output)

Write command:

Send Address	Function Code	Address High	Address Low	Register High	Address Low	Byte Count	Data 1~2	CRC
0x01~0x1F	0x10	0x00	0x43	0x00	0x01	0x02	0 or 1	Calculation by table look-up method

Command description:

Sets the **shift output** of the instrument's <System Setup> page.

0 indicates that the **shift output** of the <System Settings> page is OFF.

1 indicates that the **shift output** of the <System Settings> page is ON.

Read command:

Send Address	Function Code	Address High	Address Low	Register High	Address Low	CRC
0x01~0x1F	0x03	0x00	0x43	0x00	0x01	Calculation by table look-up

						method
--	--	--	--	--	--	--------

Return command:

Send Address	Function Code	Byte Count	Data 1~2	CRC
0x01~0x1F	0x03	0x02	0 or 1	Calculation by table look-up method

Description: Queries the **shift output** of the <System Settings> page of the instrument.

0 indicates that the **shift output** of the <System Settings> page is OFF.

1 indicates that the **shift output** of the <System Settings> page is ON.

7.3.11.4 Address 0x0044 (Power Supply Frequency)

1) Write command:

Send Address	Function Code	Address High	Address Low	Register High	Register Low	Byte Count	Data 1~2	CRC
0x01~0x1F	0x10	0x00	0x44	0x00	0x01	0x02	50 or 60	Calculation by table look-up method

Command description:

Sets the **power supply frequency** on the instrument's <System Settings> page.

2) Read command:

Send Address	Function Code	Address High	Address Low	Register High	Register Low	CRC
0x01~0x1F	0x03	0x00	0x44	0x00	0x01	Calculation by table look-up method

Return command:

Send Address	Function Code	Byte Count	Data 1~2	CRC
0x01~0x1F	0x03	0x02	50 or 60	Calculation by table look-up method

Description: Queries the **power supply frequency** on the <System Settings> page of the instrument.

7.3.11.5 Address 0x0045 (Hdl Power Supply)

Write command:

Send Address	Function Code	Address High	Address Low	Register High	Address Low	Byte Count	Data 1~2	CRC
0x01~0x1F	0x10	0x00	0x45	0x00	0x01	0x02	0 or 1	Calculation by table look-up method

Command description:

Sets the **Hdl power supply** on the instrument's <System Setup> page.0 indicates that the **Hdl power supply** on the <System Setup> page is set to internal.1 indicates that the **Hdl power supply** on the <System Setup> page is set to external.

Read command:

Send Address	Function Code	Address High	Address Low	Register High	Address Low	CRC
0x01~0x1F	0x03	0x00	0x45	0x00	0x01	Calculation by table look-up method

Return command:

Send Address	Function Code	Byte Count	Data 1~2	CRC
0x01~0x1F	0x03	0x02	0 or 1	Calculation by table look-up method

Description:

Queries the **Hdl power supply** on the instrument's <System Setup> page.0 indicates that the current **Hdl power supply** is internal.1 indicates that the current **Hdl power supply** is external.

7.3.11.6 Address 0x0046 (System Reset)

Write command:

Send Address	Function Code	Address High	Address Low	Register High	Address Low	Byte Count	Data 1~2	CRC
0x01~0x1F	0x10	0x00	0x46	0x00	0x01	0x02	0	Calculation by table look-up method

Command description:

Triggers the `system reset` for the <System Settings> page tool.

7.1 MODBUS Protocol Debugging

Note: First follow the steps in section 7.2 to debug the SCPI protocol serial communication successfully. This step is to confirm whether there is any problem with the serial port cable.

7.4.1 Instrument Settings



Figure 6-18 MODBUS

- 1) Set the 232 address to 8.
- 2) Set `PROTO` to MODBUS in `Tools`.

7.4.2 Instrument Commissioning

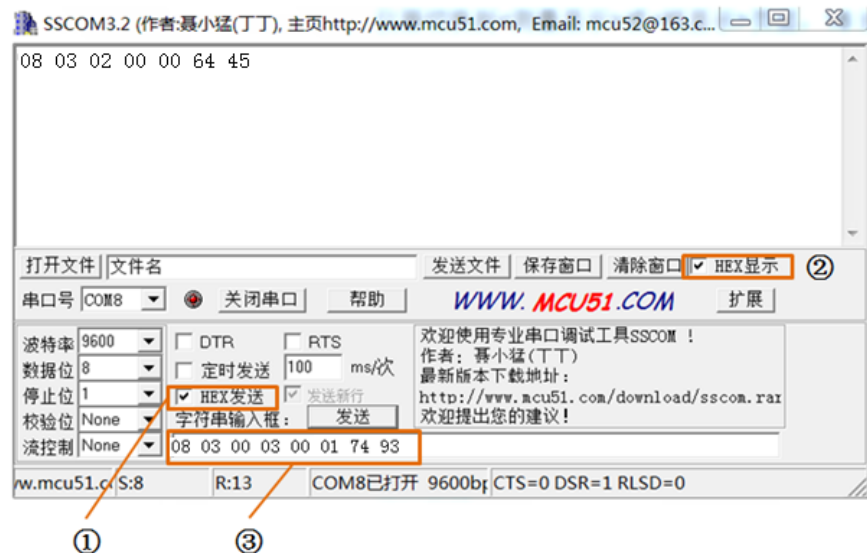

Figure 6-19 Send Command

HEX send command:

```
08 03 00 03 00 01 74 93
```

Return data:

```
08 03 02 00 00 64 45
```

If data is returned, MODBUS communication is successful.

If no data is returned, make sure

- a) The bus address is the same as the transmit address.
- b) Whether PROTO is MODBUS.

7.4.3 Getting Measurement Results

Note: The instrument returns measurement data only on the <Measurement Display> page.

7.4.3.1 Non-automatic

■ Stand-alone mode

- 1) Set Instrument <Parameter Setup>→ <Measurement Setup>→ Trigger Mode to BUS.
- 2) Send the command address 0x0E to trigger the instrument to measure once.
Send: 08 10 00 0E 00 01 02 00 00 CD 2E
Return: 08 10 00 0E 00 01 60 93
- 3) Send the command address 0x13 (<Parameter setting>→ <Boundary setting>→ Comparison status is ON) to read the measurement result.
Send: 08 03 00 13 00 04 B5 55
Return: 08 03 08 43 16 FF 56 40 00 00 00 00 C1 6C
- 4) Read the results again and repeat steps 2) and 3).
Send: 08 10 00 0E 00 01 02 00 00 CD 2E
Return: 08 10 00 0E 00 01 60 93
Send: 08 03 00 13 00 04 B5 55
Return: 08 03 08 43 17 00 D8 40 00 00 00 00 AD BC

■ Scanning mode

- 1) Set Instrument <Parameter Setup>→ <Measurement Setup>→ Trigger Mode to BUS.
- 2) Send the command address 0x0E to trigger the instrument to measure once.
Send: 08 10 00 0E 00 01 02 00 00 CD 2E
Return: 08 10 00 0E 00 01 60 93
- 3) Send command address 0x16 to set the channel number to be read.
Send: 08 10 00 16 00 01 02 00 05 0E F5
Return: 08 10 00 16 00 01 E0 94
- 4) Send the command address 0x18 (<Parameter setting>→ <Boundary setting>→ Comparison status is ON) to read the measurement result.
Send: 08 03 00 18 00 04 C4 97
Return: 08 03 08 44 81 E4 29 3F 80 00 00 68 5E
- 5) Read the results again and repeat steps 2), 3) and 4).

7.4.3.2 Semi-automatic (Recommended)

■ Stand-alone mode

- 1) Set Instrument <Parameter Setup>→ <Measurement Setup>→ Trigger Mode to BUS.
- 2) Set Instrument <System Setup>→ <Tools>→ FetcAuto to ON. (Switchboard Save)

- 3) Send command address 0x02 to trigger the instrument to measure once.
- Send: 08 03 00 02 00 01 25 53
- Return: 08 03 08 3B 54 C6 1E 40 40 00 00 41 59
- 4) Read the results again and repeat step 3).
- Send: 08 03 00 02 00 01 25 53
- Return: 08 03 08 3B 4C FD 09 40 40 00 00 A9 D0
- Scanning mode
- 1) Set Instrument <Parameter Setup>→ <Measurement Setup>→ **Trigger Mode** to BUS.
- 2) Set Instrument <System Setup>→ <Tools>→ **FetcAuto** to ON.(Switchboard Save)
- 3) Send command address 0x02 to trigger the instrument to measure once.
- Send: 08 03 00 02 00 01 25 53
- Return:
- 08 03 60
- 3f 80 00 00 40 76 66 66 40 40 00 00
- 40 00 00 00 40 93 99 9A 40 40 00 00 00
- 40 40 00 00 41 57 cc cd 40 40 00 00
- 40 80 00 00 42 CD A3 54 3F 80 00 00
- 40 a0 00 00 44 78 a4 cd 40 00 00 00 00
- 40 c0 00 00 46 1a f2 ec 40 00 00 00 00
- 40 e0 00 00 42 cd f0 21 3f 80 00 00
- 41 00 00 00 46 9A C2 66 40 00 00 00
- 03 9F
- 4) Read the results again and repeat step 3).
- Send: 08 03 00 02 00 01 25 53
- Return:
- 08 03 60
- 3f 80 00 00 3d ce f2 41 40 40 00 00 00
- 40 00 00 00 3f 7c 96 ab 40 40 00 00 00
- 40 40 00 00 41 1e 39 e0 40 40 00 00
- 40 80 00 00 42 c5 6e 2f 3f 80 00 00
- 40 a0 00 00 44 76 16 a8 40 00 00 00 00
- 40 c0 00 00 46 1a f8 85 40 00 00 00 00
- 40 e0 00 00 42 c5 5f 70 3f 80 00 00
- 41 00 00 00 46 9A CF CD 40 00 00 00 00
- 25 43

Note: Pay attention to the interval time of sending TRIG, the conventional operation is to wait until the upper computer reads the test data, and then send the next trigger command.

7.4.3.3 Fully Automatic

■ Stand-alone mode

- 1) Set Instrument <Parameter Setup>→ <Measurement Setup>→ Trigger Mode to INT.
- 2) Set Instrument <System Setup>→ <Tools>→ FetcAuto to ON.(Switchboard Save)
- 3) Each time the instrument finishes measurement, it sends the measurement result command to the host computer. The host computer simply receives the data.

Return: 08 03 04 3B 4E 9C 45 A6 F3

Return: 08 03 04 3B 4E 95 FB 20 D3

Return: 08 03 04 3B 4E 9C 45 A6 F3

■ scanning mode

- 1) Set Instrument <Parameter Setup>→ <Measurement Setup>→ Trigger Mode to INT.
- 2) Set Instrument <System Setup>→ <Tools>→ FetcAuto to ON. (Switchboard Save)
- 3) Each time the instrument finishes measurement, it sends the measurement result command to the host computer. The host computer simply receives the data.

Return: 08 03 60 3F 80 00 00 00 3D CE CD 8E 40 40 00 00 00 40 00 00 00 3F 7C
A6 65 40 40 00 00 40 40 00 00 41 1E 41 74 40 40 00 00 40 80 00 00 42 C5 7B 7F 3F 80
00 00 40 A0 00 00 44 76 26 56 40 00 00 00 00 40 c0 00 00 46 1b 02 29 40 00 00 00 40
e0 00 00 42 c5 6c 3d 3f 80 00 00 41 00 00 00 46 9a d9 cd 40 00 00 00 00 c6 e1

Return: 08 03 60 3F 80 00 00 00 3D CE C7 43 40 40 00 00 00 40 00 00 00 3F 7C
A8 3B 40 40 00 00 40 40 00 00 41 1E 41 9E 40 40 00 00 40 80 00 00 42 C5 7C AC 3F
80 00 00 40 A0 00 00 44 76 28 42 40 00 00 00 00 40 c0 00 00 46 1b 03 e1 40 00 00 00
40 e0 00 00 42 c5 6e 8a 3f 80 00 00 41 00 00 00 46 9a db 66 40 00 00 00 00 c6 36

Return: 08 03 60 3F 80 00 00 00 3D CE CD 08 40 40 00 00 40 00 00 00 3F 7C A7
A4 40 40 00 00 40 40 00 00 41 1E 42 8F 40 40 00 00 40 80 00 00 42 C5 7C 50 3F 80 00
00 40 A0 00 00 00 44 76 29 89 40 00 00 00 00 40 c0 00 00 46 1b 02 e1 40 00 00 00 40
e0 00 00 42 c5 6e 70 3f 80 00 00 41 00 00 00 46 9a da 9a 40 00 00 00 9c d1

7.5 MODBUS Commands Detailed Description

7.5.1 Send Address and Command Address

Send address:

The transmit address is the **232 address** under the instrument's <System Settings> page.

Command address:

The Command address is the address high and address low bits in the command format.

7.5.2 Data byte 1~n

If the total number of bytes is 2, data byte 1 belongs to the high 8 bits and data byte 2 data low 8 bits, forming a 16-bit integer.

If the total number of bytes is 4, data byte 1 belongs to the highest 8 bits of the floating-point number, data byte 4 data lowest 8 bits, data byte 1 to data byte 4 form a floating-point number.

If the total number of bytes is 8, it means 2 floating-point numbers, data byte 1 to data byte 4 form the first floating-point number, data byte 5 to data byte 8 form the second floating-point number.

For example, decimal number 25.16, converted hexadecimal number is 0x41 0xC9 0x47 0xAE, then data byte 1 is 0x41, data byte 2 is 0xC9, data byte 3 is 0x47, data byte 4 is 0xAE. if stored in a 4-byte array, then a[0]=0xAE, a[1]=0x47, a[2]=0xC9, a[3]= 0x41.

7.5.3 CRC Low and CRC High

The MODBUS Command CRC16 calibration of this instrument adopts the look-up table method. The specific codes are as follows:

```
//CRC16 High Byte Value Table
const U8 Crc16HighTable[] =
{
0x00,0xC1,0x81,0x40,0x01,0xC0,0x80,0x41,0x01,0xC0,0x80,0x41,0x00,0xC1,0x81,0x40,
0x01,0xC0,0x80,0x41,0x00,0xC1,0x81,0x40,0x00,0xC1,0x81,0x40,0x01,0xC0,0x80,0x41,
0x01,0xC0,0x80,0x41,0x00,0xC1,0x81,0x40,0x00,0xC1,0x81,0x40,0x01,0xC0,0x80,0x41,
0x00,0xC1,0x81,0x40,0x01,0xC0,0x80,0x41,0x01,0xC0,0x80,0x41,0x00,0xC1,0x81,0x40,
0x01,0xC0,0x80,0x41,0x00,0xC1,0x81,0x40,0x00,0xC1,0x81,0x40,0x01,0xC0,0x80,0x41,
0x01,0xC0,0x80,0x41,0x00,0xC1,0x81,0x40,0x00,0xC1,0x81,0x40,0x01,0xC0,0x80,0x41,
0x00,0xC1,0x81,0x40,0x01,0xC0,0x80,0x41,0x01,0xC0,0x80,0x41,0x00,0xC1,0x81,0x40,
0x00,0xC1,0x81,0x40,0x01,0xC0,0x80,0x41,0x01,0xC0,0x80,0x41,0x00,0xC1,0x81,0x40,
0x01,0xC0,0x80,0x41,0x00,0xC1,0x81,0x40,0x00,0xC1,0x81,0x40,0x01,0xC0,0x80,0x41,
0x01,0xC0,0x80,0x41,0x00,0xC1,0x81,0x40,0x00,0xC1,0x81,0x40,0x01,0xC0,0x80,0x41,
0x00,0xC1,0x81,0x40,0x01,0xC0,0x80,0x41,0x01,0xC0,0x80,0x41,0x00,0xC1,0x81,0x40,
0x01,0xC0,0x80,0x41,0x00,0xC1,0x81,0x40,0x00,0xC1,0x81,0x40,0x01,0xC0,0x80,0x41,
0x01,0xC0,0x80,0x41,0x00,0xC1,0x81,0x40,0x00,0xC1,0x81,0x40,0x01,0xC0,0x80,0x41,
0x00,0xC1,0x81,0x40,0x01,0xC0,0x80,0x41,0x01,0xC0,0x80,0x41,0x00,0xC1,0x81,0x40,
};
```

```
//CRC16 Low Byte Value Table
const U8 Crc16LowTable[] =
{
0x00,0xC0,0xC1,0x01,0xC3,0x03,0x02,0xC2,0xC6,0x06,0x07,0xC7,0x05,0xC5,0xC4,
0x04,0xCC,0x0C,0x0D,0xCD,0x0F,0xCF,0xCE,0x0E,0x0A,0xCA,0xCB,0x0B,0xC9,0x09,
0x08,0xC8,0xD8,0x18,0x19,0xD9,0x1B,0xDB,0xDA,0x1A,0x1E,0xDE,0xDF,0x1F,0xDD,
0x1D,0x1C,0xDC,0x14,0xD4,0xD5,0x15,0xD7,0x17,0x16,0xD6,0xD2,0x12,0x13,0xD3,
0x11,0xD1,0xD0,0x10,0xF0,0x30,0x31,0xF1,0x33,0xF3,0xF2,0x32,0x36,0xF6,0xF7,0x37,
0xF5,0x35,0x34,0xF4,0x3C,0xFC,0xFD,0xD3C,0xFF,0x3F,0x3E,0xFE,0xFA,0x3A,0x3B,
0xFB,0x39,0xF9,0xF8,0x38,0x28,0xE8,0xE9,0x29,0xEB,0x2B,0x2A,0xEA,0xEE,0x2E,0x2F,
0xEF,0x2D,0xED,0xEC,0x2C,0xE4,0x24,0x25,0xE5,0x27,0xE7,0xE6,0x26,0x22,0xE2,
0xE3,0x23,0xE1,0x21,0x20,0xE0,0xA0,0x60,0x61,0xA1,0x63,0xA3,0xA2,0x62,0x66,0xA6,
0xA7,0x67,0xA5,0x65,0x64,0xA4,0x6C,0xAC,0xAD,0x6D,0xAF,0x6F,0x6E,0xAE,0xAA,
0xA6,0x66,0xAB,0x69,0xA9,0xA8,0x68,0x78,0xB8,0xB9,0x79,0xBB,0x7B,0x7A,0xBA,
0xBE,0x7E,0x7F,0xBF,0x7D,0xBD,0xBC,0x7C,0xB4,0x74,0x75,0xB5,0x77,0xB7,0xB6,
0x76,0x72,0xB2,0xB3,0x73,0xB1,0x71,0x70,0xB0,0x50,0x90,0x91,0x51,0x93,0x53,0x52,
0x92,0x96,0x56,0x57,0x97,0x55,0x95,0x94,0x54,0x9C,0x5C,0x5D,0x9D,0x5F,0x9F,0x9E,
0x5E,0x5A,0x9A,0x9B,0x5B,0x99,0x59,0x58,0x98,0x88,0x48,0x49,0x89,0x4B,0x8B,0x8A,
0x4A,0x4E,0x8E,0x8F,0x4F,0x8D,0x4D,0x4C,0x8C,0x44,0x84,0x85,0x45,0x87,0x47,0x46,
0x86,0x82,0x42,0x43,0x83,0x41,0x81,0x80,0x40,
};
```

```
U16 CalcCrc16Code(char *pbuf, U16 size)
{
U8 crc_high = 0xFF;
U8 crc_low = 0xFF;
U8 crc_index;
U16 crc_code;

while(size--)
{
crc_index = crc_low ^ *pbuf++;
crc_low = crc_high ^ Crc16HighTable[crc_index];
crc_high = Crc16LowTable[crc_index];
}
```

```

}
crc_code = ((crc_high << 8) | crc_low);

return(crc_code);
}

```

7.5.4 Return Command Format

0	1	2	3	4	5	6	7	8	9	10	11	12
Send Address	Function Code	Byte Count	Data byte 1	Data byte 2	Data byte 3	Data byte 4	Data byte 5	Data byte 6	Data byte 7	Data byte 8	CRC Low	CRC High

Send address: instrument 232 address

Function Code: 0x03

Total number of bytes: 0x08

Data 1~Data 4: Resistance value of the measured part, floating-point hexadecimal representation. The high byte is in the front and the low byte is in the back. **The number of bytes is 4, data byte 1 belongs to the highest 8 bits of the floating-point number, data byte 4 data lowest 8 bits, data byte 1 to data byte 4 form a floating-point number.** See the website: <http://lostphp.com/hexconvert/> for the conversion of the progression system. As shown in the figure below:

IEEE 754浮点数十六进制相互转换(32位,四字
节,单精度)

10进制 24.14204978942871

16进制 41 C1 22 EB

Data 5~Data 8: Status of the measurement result, 0 means that the measurement result value is valid.

7.5.5 Actual Example

Send: 08 03 00 02 00 01 25 53

Return data description:

08 Send address

03 Function code

54 Total number of bytes

3F 80 00 00 Converts decimal number to 1, indicating channel CH1

3D D4 BE 83 Converts decimal number to 0.103879, indicating the measured value of channel CH1

3F 80 00 00 Converts decimal number to 1, indicating that the CH1 comparison result is qualified

40 00 00 00 Converts decimal number to 2, indicating channel CH2

3F 80 8E 37 Converts decimal number to 1.0043, indicating the measured value of channel CH2

3F 80 00 00 Converts decimal number to 1, indicating that the CH2 comparison result is qualified

40 40 00 00 Converts decimal number to 3, indicating channel CH3

43 0F F5 C3 converts decimal number to 143.96, indicating the measured value of channel CH3

40 00 00 00 Converts decimal number to 2, indicating that the CH3 comparison result is disqualified

40 80 00 00 Converts decimal number to 4, indicating channel CH4

42 CC 07 2B Converts decimal number to 102.014, indicating the measured value of channel CH4

40 00 00 00 Converts decimal number to 2, indicating that the CH4 comparison result is disqualified

40 A0 00 00 Converts decimal number to 5, indicating channel CH5

44 81 CA E1 Converts decimal number to 1038.34, indicating the measured value of channel CH5

3F 80 00 00 Converts decimal number to 1, indicating that the CH5 comparison result is qualified

40 C0 00 00 Converts decimal number to 6, indicating channel CH6

46 0B C3 AE Converts decimal number to 8944.92, indicating the measured value of channel CH6

40 00 00 00 Converts decimal number to 2, indicating that the CH6 comparison result is disqualified

40 E0 00 00 Converts decimal number to 7, indicating channel CH7

44 B3 9A E1 Converts decimal number to 1436.84, indicating the measured value of channel CH7

3F 80 00 00 Converts decimal number to 1, indicating that the CH7 comparison result is qualified

AC 84 CRC checksum

Chapter 8 Handler Interface Usage Notes

TH2518 series DC Resistance/Temperature Scanners provide users with a Handler interface, which is mainly used for inputting signals such as triggers and outputting sorting results. When the instrument is used in automatic component sorting test system, this interface provides the contact signal with the system and the output signal of sorting results.

8.2 Handler Ports and Specific Meanings

Port Number	Port Name	Meaning
1	O_RESERVE D2	Reserved bit
2	EXT_GND	External Power Ground This signal is connected to the internal power supply INT_GND when the Hdl power supply is set to internal in the <System Setup> page. When Hdl Power is set to External on the <System Setup> page, this port is an external power input with a voltage range of +5V to +30V.
3	INT_VCC	Internal +5V power output. It is not recommended that the user use the instrument's internal power supply, if you must use it, make sure that the current is less than 0.3A and should be far away from sources of interference.
4	NC	Empty pin
5	NC	Empty pin
6	SCLK	The shift clock signal, together with SER, RCK, realizes the shift output of 90 comparison result signals.
7	PUMP	Air pump control signal, the output level is controlled by the command SYST:PUMP ON, see SCPI command system for details.
8	/EOC	AD end signal, active low
9	/PASS5	<Channel Setup> page is set to all open channels of U5 whose test comparison results pass, this pin outputs a low level. If one fails, output high level.
10	/PASS3	<Channel Setup> page is set to all open channels of U3 whose test comparison results pass, this pin outputs a low level. If one fails, output high level.
11	/PASS1	<Channel Setup> page is set to all open channels of U1 whose test comparison results pass, this pin outputs a low level. If one fails, output high level.
12	/Keylock	Key Lock Input Signal, Low Active, when this signal is active, all touch keys as well as the keys on the front panel are disabled.
13	/START	Measurement trigger input signal, falling edge valid. When the instrument is in external trigger mode or internal trigger mode in scan mode, the instrument will perform a trigger measurement when this signal is valid.
14	O_RESERVE D1	Reserved bit
15	EXT_VCC	External power input This signal is connected to the internal power supply INT_VCC when the Hdl power supply is set to internal in the <System Setup> page. When Hdl Power is set to External on the <System Setup> page, this port is an external power input with a voltage range of +5V to +30V.
16	INT_GND	Internal power ground
17	NC	Empty pin
18	RCK	Shift latch signals, together with SER, SCLK, realize the shift output of 90 comparison result signals.
19	SER	Shift data signals, together with RCK, SCLK, realize the shift output of 90 comparison result signals.

20	/EOT	Measurement end signal, low active
21	/PASS6	<Channel Setup> page is set to all open channels of U6 whose test comparison results pass, this pin outputs a low level. If one fails, output high level.
22	/PASS4	<Channel Setup> page is set to all open channels of U4 whose test comparison results pass, this pin outputs a low level. If one fails, output high level.
23	/PASS2	<Channel Setup> page is set to all open channels of U2 whose test comparison results pass, this pin outputs a low level. If one fails, output high level.
24	/PASS_TOTAL	Scan mode: all open channels whose test comparison results pass, this pin outputs a low level. If one fails, output high level. Stand-alone mode: test comparison pass, output low level. Otherwise output high and low level.
25	/STOP	Measurement stop input signal. Low Valid, in scanning mode, when this signal is valid, the instrument will stop the current test immediately and will not output the current test result.

Note: After using the Channel Compare Sort Board, EXT-VCC and EXT-GND are moved to the port of the Sort Board. In this case, pins 15 and 3 of the Handler port are internal power, and pins 2 and 16 are internal ground. When the Channel Comparison Sorting Board is not used, the external power supply is separated from the internal power supply, and the external ground is separated from the internal ground.

8.2 Handler Timing Diagram

8.2.1 Stand-alone Mode

When the test function is R and temperature compensation is off or when the test function is T

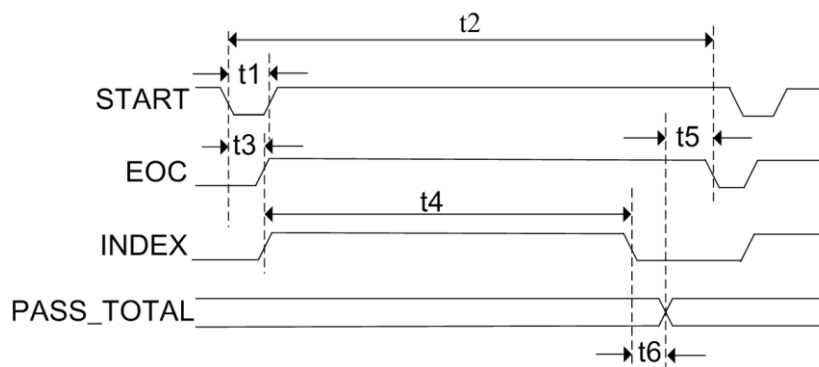

When the test function is R and temperature compensation is on or when the test function is R-T

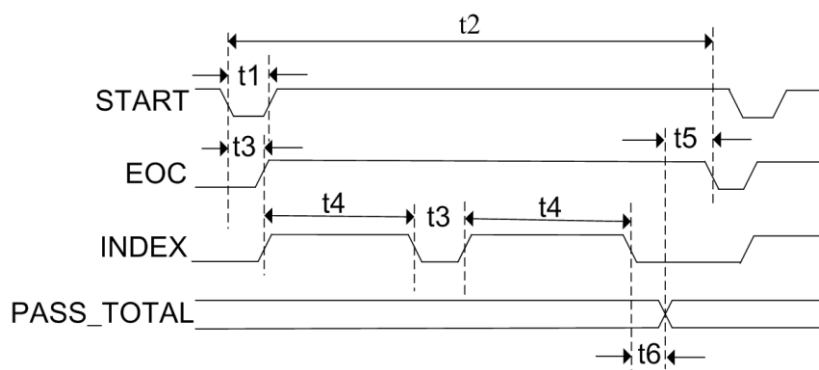

Timing	Minimum Value	Maximum Value
t1: Trigger pulse width	1us	---
t2: One measurement time	t_3+t_4	---
t3: Measurement delay time	See measurement delay setting	---
t4: Sampling time for one measurement	Sampling Time ^[1]	---
t5: Time to format and display test results	Display "On": 17ms Display "Off": 2.5ms	---
t6: Data processing sorting output time	50us	---

8.2.2 Scanning Mode

When temperature compensation is OFF

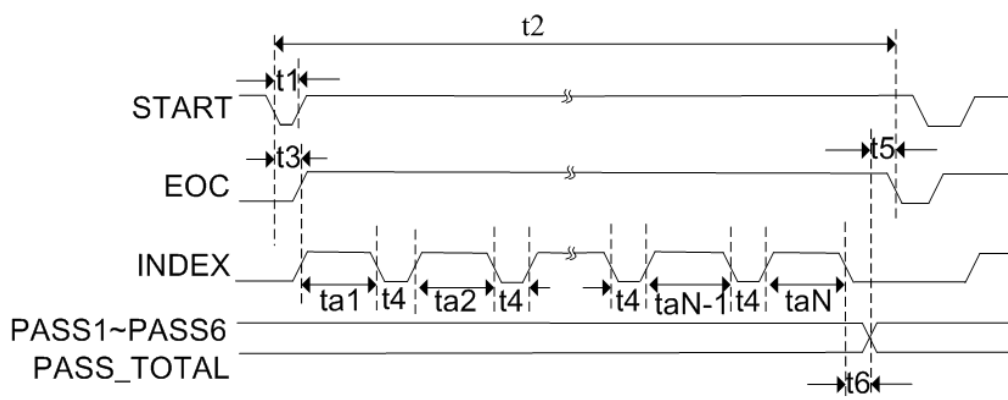

When test function is R or R-T and temperature compensation is ON

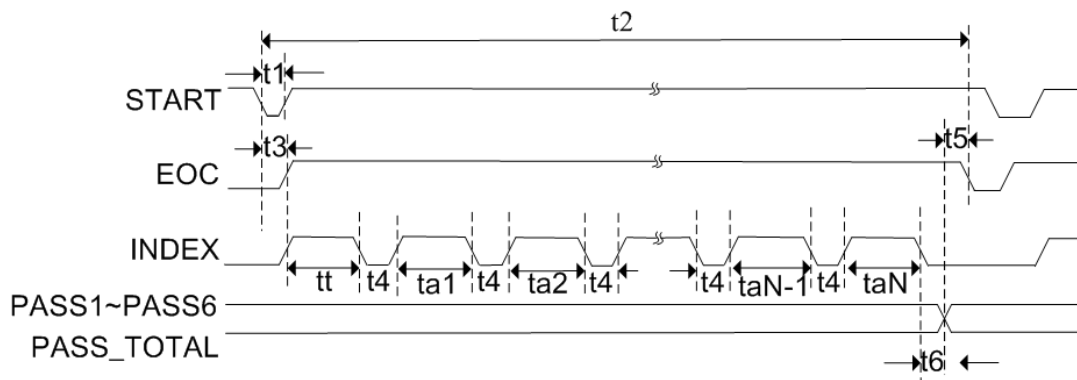

Note: P1/P2/P3 is the PASS1/PASS2/PASS3 signal.

Timing	Minimum Value	Maximum Value
t1: Trigger pulse width	1us	---
t2: One measurement time	$t_3+t_4*(N^{[2]}-1)+tt+ta_1+-----+ta_N$	---
t3: Measurement delay time	See measurement delay setting	---
t4: Single-step measurement data processing, display time, channel switching and measurement delay time	8ms+t3	---
t5: Display time	Shift output time for 90-way comparison results Shift "on": 10ms Shift "Off": 0ms	---
t6: Data processing sorting output time	4ms	---

ta1,ta2.....taN-1,taN ^[2]	Sampling Time ^[1]	---
tt: temperature test time	Sampling Time ^[1]	---

Note 1: Sampling Time =

6ms * Average (50 Hz) / 5ms * Average (60 Hz) Fast

21 ms * Average (50 Hz) / 16.6ms (60 Hz) * Average Medium

105 ms * Average (50 Hz) / 110ms * Average (60 Hz) Slow

Average is the average of <Measurement Settings>.

Note 2: The number of tests (i.e., steps) required for scanning, i.e., the maximum number of test channels required in the six test units, e.g., the first test unit has six test channels; the second test unit has five test channels; the third test unit has seven test channels; the fourth test unit has eight test channels; the fifth test unit has nine test channels; and the sixth test unit has eight test channels. Then N is 9.

Note 3: The above test timings are obtained when the range is locked, if the range selection is automatic, the time when searching for the range should be added.

8.2.3 Shift Output Timing of Comparison Results for **Each** Test Channel

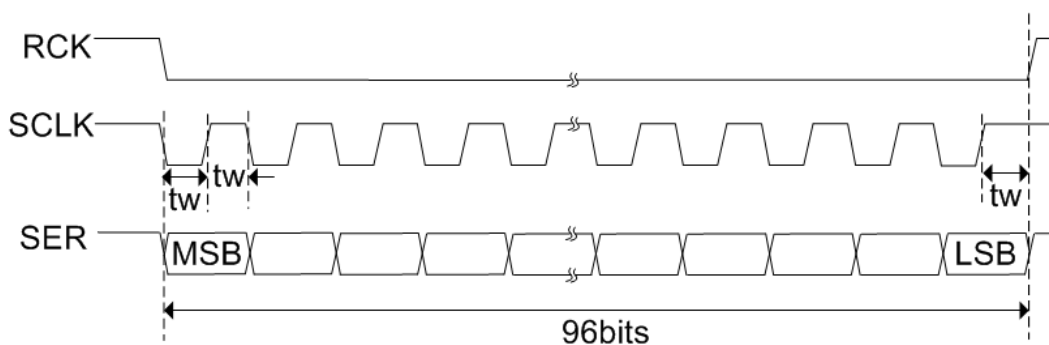

Note 1: Pulse width btw: 50uS

Note 2: In all open test channels, the MSB bit is the sorting result of the channel with the smallest number of sequences, and the LSB is the sorting result of the channel with the largest number of sequences (for details, refer to the description attached to the sorting board).

Note 3: The total number of bits shifted out is the number of open test channels, up to 96 bits.

Note 4: The sorting result is **low valid**, i.e., when the sorting result of one channel is qualified, the output sorting signal is **low**.

Note 5: Test channels with comparison not turned on or not enabled are treated as failed outputs.

8.2.4 Electrical Characteristics

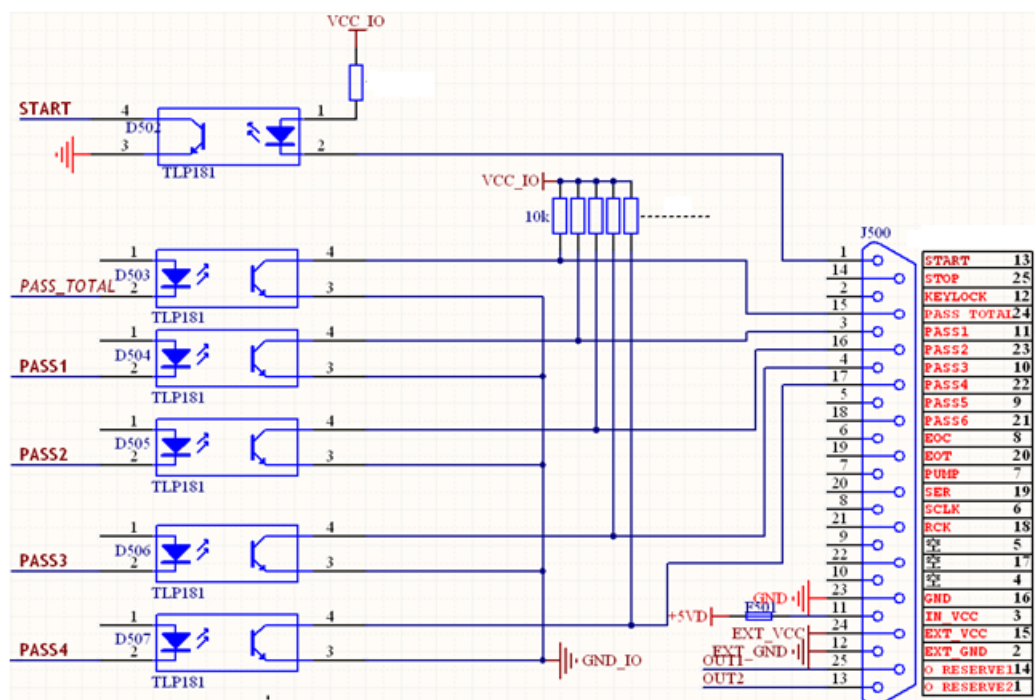

VCC_IO: Handler interface power supply, should be set as EXT_VCC or INT_VCC.

GND_IO: Handler interface ground, should be set as EXT_GND or INT_GND.

Note: The three signals SCLK/RCK/SER, without going through the optocoupler and pull-up resistor shown above, are directly from the CPU to the Handler interface. These three signals are used with the **single-channel comparative sorting board accessory** (see below for details) for the single-channel sorting output of qualified and unqualified signals.

8.3 Channel Comparison Sorting Board-TH2518-01

8.3.1 Introduction to Sorting Board

Based on the instrument's Handler interface, the TH2518 series DC resistance/temperature scanner is provided with a comparison and sorting board for each test channel, as shown in the figure below. On the basis of retaining all the signals on the original Handler (comparative sorting signals (PASS-TOTAL) and comparative sorting signals at the scanner board level (PASS1-PASS6), etc.), it extends the sorting output signals of the test channels. The sorting board is flexible and easy to use and can be plugged into the Handler interface of the instrument.

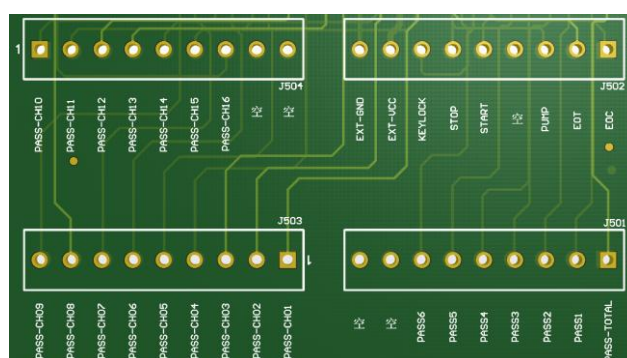

8.3.2 Sorting Board Ports and Port Description

Port Number	Port Name	Meaning
J501-1	PASS-TOTAL	Scan mode: all open channels whose test comparison results pass, this pin outputs a low level. If one fails, output high level. Stand-alone mode: test comparison pass, output low level. Otherwise output high and low level.
J501-2	PASS1	<Channel Setup> page is set to all open channels of U1 whose test comparison results pass, this pin outputs a low level. If one fails, output high level.
J501-3	PASS2	<Channel Setup> page is set to all open channels of U2 whose test comparison results pass, this pin outputs a low level. If one fails, output high level.
J501-4	PASS3	<Channel Setup> page is set to all open channels of U3 whose test comparison results pass, this pin outputs a low level. If one fails, output high level.
J501-5	PASS4	<Channel Setup> page is set to all open channels of U4 whose test comparison results pass, this pin outputs a low level. If one fails, output high level.
J501-6	PASS5	<Channel Setup> page is set to all open channels of U5 whose test comparison results pass, this pin outputs a low level. If one fails, output high level.
J501-7	PASS6	<Channel Setup> page is set to all open channels of U6 whose test comparison results pass, this pin outputs a low level. If one fails, output high level.
J501-8	NC	Empty pin
J501-9	NC	Empty pin
J502-1	EOC	Measurement end signal. Low active.
J502-2	EOT	AD end signal, low active.
J502-3	PUMP	Air pump control signal, the output level is controlled by the command SYST:PUMP ON, see SCPI command system for details.
J502-4	NC	Empty pin
J502-5	START	Measurement trigger input signal, falling edge valid. When the instrument is in external trigger mode or internal trigger mode in scan mode, the instrument will perform a trigger measurement when this signal is valid.
J502-6	STOP	Measurement stop input signal. Low Valid, in scanning mode, when this signal is valid, the instrument will stop the current test immediately and will not output the current test result.
J502-7	KEYLOCK	Key Lock Input Signal, Low Active, when this signal is active, all touch keys as well as the keys on the front panel are disabled.
J502-8	EXT_VCC	External power input, voltage range +5V~+30V, generally 24V.
J502-9	EXT_GND	External power ground
J503-1	PASS-CH01	Number 1 sorting output. Pass is low, fail is high.
J503-2	PASS-CH02	Number 2 sorting output. Pass is low, fail is high.
J503-3	PASS-CH03	Number 3 sorting output. Pass is low, fail is high.
J503-4	PASS-CH04	Number 4 sorting output. Pass is low, fail is high.
J503-5	PASS-CH05	Number 5 sorting output. Pass is low, fail is high.
J503-6	PASS-CH06	Number 6 sorting output. Pass is low, fail is high.
J503-7	PASS-CH07	Number 7 sorting output. Pass is low, fail is high.
J503-8	PASS-CH08	Number 8 sorting output. Pass is low, fail is high.
J503-9	PASS-CH09	Number 9 sorting output. Pass is low, fail is high.
J504-1	PASS-CH10	Number 10 sorting output. Pass is low, fail is high.
J504-2	PASS-CH11	Number 11 sorting output. Pass is low, fail is high.

J504-3	PASS-CH12	Number 12 sorting output. Pass is low, fail is high.
J504-4	PASS-CH13	Number 13 sorting output. Pass is low, fail is high.
J504-5	PASS-CH14	Number 14 sorting output. Pass is low, fail is high.
J504-6	PASS-CH15	Number 15 sorting output. Pass is low, fail is high.
J504-7	PASS-CH16	Number 16 sorting output. Pass is low, fail is high.
J504-8	NC	Empty pin
J504-9	NC	Empty pin

8.3.3 Cascade of Sorting Board

When the number of channels to be tested is greater than 16, a cascade to the binning board is used.

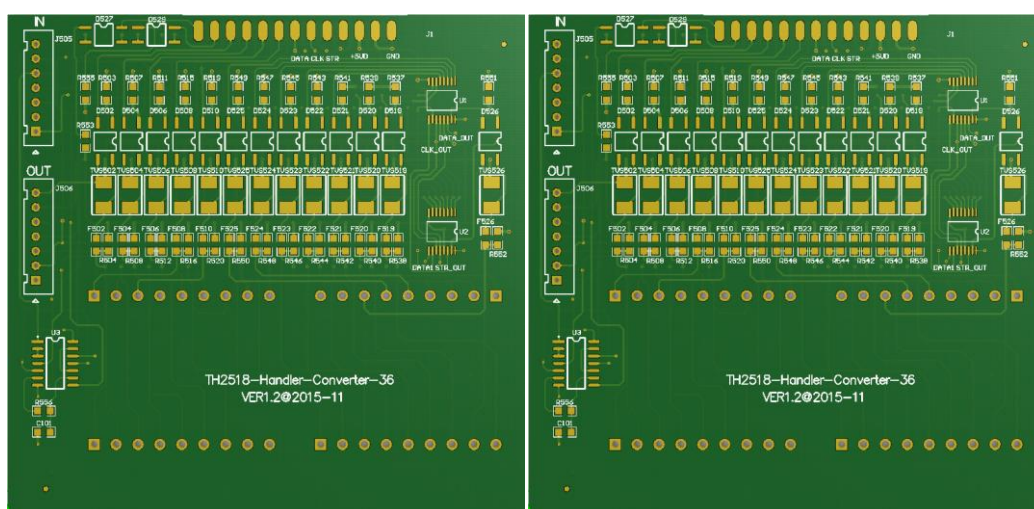

First sorting plate Second sorting plate

The connection method is as follows:

- 1) The ZHC-7P holder (IN) of the first sorting board is plugged into the HANDLER port of the main unit.
- 2) The ZHC-7P holder (OUT) of the first sorting board is connected to the ZHC-7P holder (IN) of the second sorting board, using the ZHC-7P cable for one-to-one corresponding connection (pin 1 corresponds to pin 17 corresponds to pin 7).
- 3) The ZHC-7P holder (OUT) of the second sorting board is connected to the ZHC-7P holder (IN) of the third sorting board, using the ZHC-7P cable for one-to-one connection (pin 1 corresponds to pin 17 corresponds to pin 7).
- 4) Fourth, fifth, sixth sorting boards and so on.

External power and external ground connections to either the first or second tap are available.

8.3.4 Sorting Mode OneToOne

A single board supports up to 16 channels of single-channel sorting and comparison results output. The cascading of 6 sorting boards can support up to 90 channels of sorting and comparison result output. When the sorting mode is set to **OneToOne** in the **<Parameter Setting>** page, the corresponding situation is as follows:

The first sorting board corresponds as follows:

CH01 ↔ PASS-CH01	CH09 ↔ PASS-CH09
CH02 ↔ PASS-CH02	CH10 ↔ PASS-CH10
CH03 ↔ PASS-CH03	CH11 ↔ PASS-CH11
CH04 ↔ PASS-CH04	CH12 ↔ PASS-CH12
CH05 ↔ PASS-CH05	CH13 ↔ PASS-CH13
CH06 ↔ PASS-CH06	CH14 ↔ PASS-CH14
CH07 ↔ PASS-CH07	CH15 ↔ PASS-CH15
CH08 ↔ PASS-CH08	CH16 ↔ PASS-CH16

The second sorting board corresponds as follows:

CH17 ↔ PASS-CH01	CH25 ↔ PASS-CH09
CH18 ↔ PASS-CH02	CH26 ↔ PASS-CH10
CH19 ↔ PASS-CH03	CH27 ↔ PASS-CH11
CH20 ↔ PASS-CH04	CH28 ↔ PASS-CH12
CH21 ↔ PASS-CH05	CH29 ↔ PASS-CH13
CH22 ↔ PASS-CH06	CH30 ↔ PASS-CH14
CH23 ↔ PASS-CH07	CH31 ↔ PASS-CH15
CH24 ↔ PASS-CH08	CH32 ↔ PASS-CH16

The third sorting board corresponds as follows:

CH33 ↔ PASS-CH01	CH41 ↔ PASS-CH09
CH34 ↔ PASS-CH02	CH42 ↔ PASS-CH10
CH35 ↔ PASS-CH03	CH43 ↔ PASS-CH11
CH36 ↔ PASS-CH04	CH44 ↔ PASS-CH12
CH37 ↔ PASS-CH05	CH45 ↔ PASS-CH13
CH38 ↔ PASS-CH06	CH46 ↔ PASS-CH14
CH39 ↔ PASS-CH07	CH47 ↔ PASS-CH15
CH40 ↔ PASS-CH08	CH48 ↔ PASS-CH16

The fourth sorting plate corresponds as follows:

CH49 ↔ PASS-CH01	CH57 ↔ PASS-CH09
CH50 ↔ PASS-CH02	CH58 ↔ PASS-CH10
CH51 ↔ PASS-CH03	CH59 ↔ PASS-CH11
CH52 ↔ PASS-CH04	CH60 ↔ PASS-CH12
CH53 ↔ PASS-CH05	CH61 ↔ PASS-CH13
CH54 ↔ PASS-CH06	CH62 ↔ PASS-CH14
CH55 ↔ PASS-CH07	CH63 ↔ PASS-CH15
CH56 ↔ PASS-CH08	CH64 ↔ PASS-CH16

The fifth sorting board corresponds as follows:

CH65 ↔ PASS-CH01	CH73 ↔ PASS-CH09
CH66 ↔ PASS-CH02	CH74 ↔ PASS-CH10
CH67 ↔ PASS-CH03	CH75 ↔ PASS-CH11
CH68 ↔ PASS-CH04	CH76 ↔ PASS-CH12
CH69 ↔ PASS-CH05	CH77 ↔ PASS-CH13
CH70 ↔ PASS-CH06	CH78 ↔ PASS-CH14
CH71 ↔ PASS-CH07	CH79 ↔ PASS-CH15
CH72 ↔ PASS-CH08	CH80 ↔ PASS-CH16

The sixth sorting plate corresponds as follows:

CH81 ↔ PASS-CH01	CH89 ↔ PASS-CH09
CH82 ↔ PASS-CH02	CH90 ↔ PASS-CH10
CH83 ↔ PASS-CH03	
CH84 ↔ PASS-CH04	
CH85 ↔ PASS-CH05	
CH86 ↔ PASS-CH06	

CH87 ↔ PASS-CH07	
CH88 ↔ PASS-CH08	

8.3.5 Sorting Mode SHIFT

A single board supports up to 16 channels of single-channel sorting and comparison results output. A cascade of 6 sorting boards can support up to 90 channels of sorting and comparison results output. The order of shifting depends on the channel number of the test channel (i.e., the channel with the smallest number is shifted out first), so the correspondence between the output sorting channel and the test channel may change according to the change of the test channel setting. When the sorting mode is set to **SHIFT** in the parameter setting page, users can refer to the following situations for analysis:

- 1) Number of open channels less than 16

E.g. 1: CH01~CH08 ON, rest OFF. At this time: CH01↔PASS-CH09, CH02↔PASS-CH10,, CH08↔PASS-CH16.

E.g. 2: CH01~CH03 ON, rest OFF. At this time: CH01↔PASS-CH14, CH02↔PASS-CH15, CH03↔PASS-CH16.

E.g. 3: CH7~CH09 ON, rest OFF. At this time: CH07 ↔ PASS-CH14, CH08 ↔ PASS-CH15, CH09 ↔ PASS-CH16.

E.g. 4: CH01, CH03, CH05, CH07 ON, rest OFF. At this time: CH01↔PASS-CH13, CH03↔PASS-CH14, CH05↔PASS-CH15, CH07↔PASS-CH16.

- 2) The number of open channels is equal to 16

E.g. 1: CH01~CH16 ON, rest OFF. At this time: CH01↔PASS-CH01, CH02↔PASS-CH02,, CH16↔PASS-CH16.

E.g. 2: CH03~CH18 ON, rest OFF. At this time: CH03↔PASS-CH01, CH04↔PASS-CH02,, CH18↔PASS-CH16.

E.g. 3: CH02, CH04, CH05, CH07, CH09, CH11, CH12, CH13, CH15, CH17, CH20, CH23, CH25, CH26, CH28, CH30 ON and the rest OFF. At this time:

CH02 ↔ PASS-CH01, CH04 ↔ PASS-CH02, CH05 ↔ PASS-CH03, CH07 ↔ PASS-CH04, CH09 ↔ PASS-CH05, CH11 ↔ PASS-CH06, CH12 ↔ PASS-CH07, CH13 ↔ PASS-CH08, CH15 ↔ PASS-CH09, CH17 ↔ PASS-CH10, CH20 ↔ PASS-CH11, CH23 ↔ PASS-CH12, CH25 ↔ PASS-CH13, CH26 ↔ PASS-CH14, CH28 ↔ PASS-CH15, CH30 ↔ PASS-CH16

- 3) Number of open channels greater than 16

If 1: CH01~CH17 ON, rest OFF. At this time:

CH01 ↔ PASS-CH16 for the second sorting board.

CH02 ↔ PASS-CH01 for the first sorting board.

CH03 ↔ PASS-CH02 for the first sorting board.

.....

CH17 ↔ PASS-CH16 for the first sorting board.

E.g. 2: CH03~CH19 ON, rest OFF. At this time:

CH03 ↔ PASS-CH16 for the second sorting board.

CH04 ↔ PASS-CH01 for the first sorting board.

CH05 ↔ PASS-CH02 for the first sorting board.

.....

CH19 ↔ PASS-CH16 for the first sorting board.

E.g. 3: CH02, CH04, CH05, CH07, CH09, CH11, CH12, CH13, CH15, CH17, CH20, CH23, CH25, CH26, CH28, CH30, CH32 ON, rest OFF. At this time:

CH02 ↔ PASS-CH16 for the second sorting plate, CH04 ↔ PASS-CH01 for the first sorting plate.

CH05 ↔ PASS-CH02 for the first sorting board, CH07 ↔ PASS-CH03 for the first sorting board.

CH09 ↔ PASS-CH04 for the first sorting board, CH11 ↔ PASS-CH05 for the first sorting board.

CH12 ↔ PASS-CH06 for the first sorting board, CH13 ↔ PASS-CH07 for the first sorting board.

CH15 ↔ PASS-CH08 for the first sorting board, CH17 ↔ PASS-CH09 for the first sorting board.

CH20 ↔ PASS-CH10 for the first sorting plate, CH23 ↔ PASS-CH11 for the first sorting plate.

CH25 ↔ PASS-CH12 for the first sorting board, CH26 ↔ PASS-CH13 for the first sorting board.

CH28 ↔ PASS-CH14 for the first sorting board, CH30 ↔ PASS-CH15 for the first sorting board.

CH32 ↔ PASS-CH16 for the first sorting plate

Note: When the number of channels tested is greater than 16, a cascade of sorting boards is required to sort multiple channels. the PASS-CH16 is always the last open channel tested.

8.3.6 Sorting Board Shift Output Signal Sketch

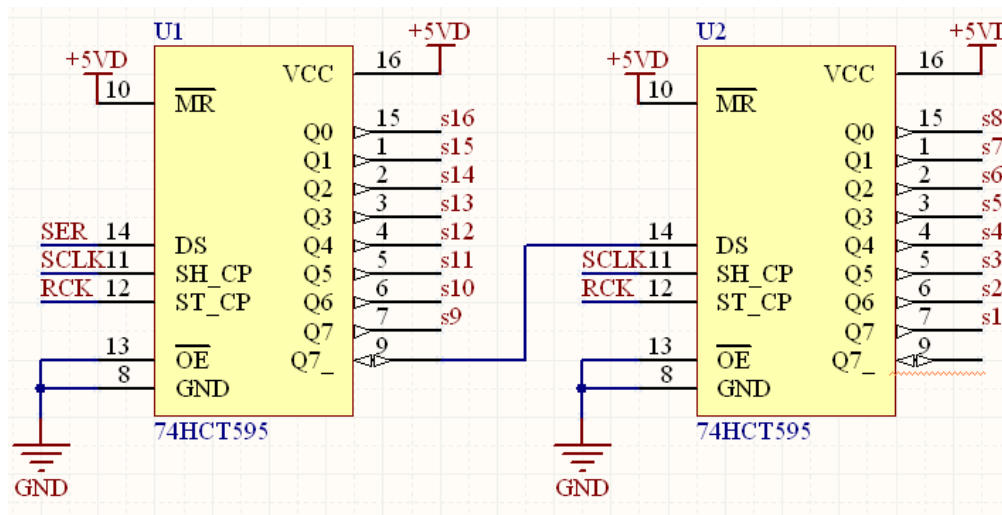

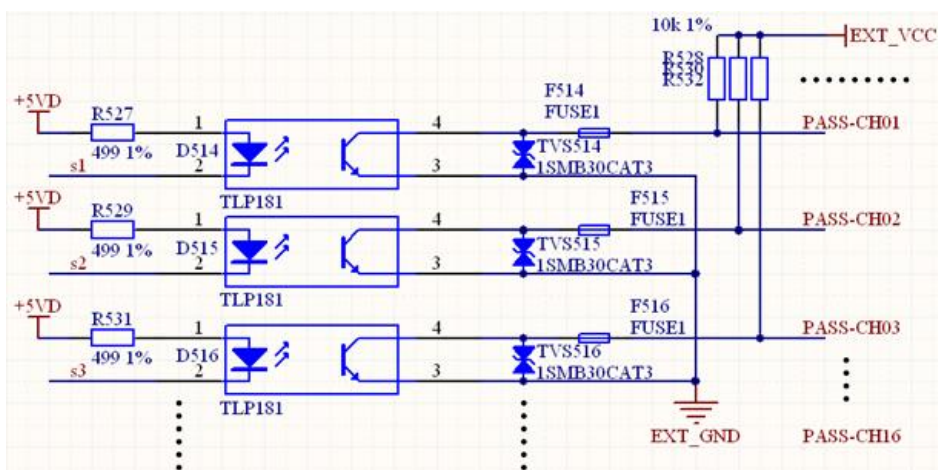

8.3.7 Precautions for Use

First of all, this scanning channel comparison sorting board only supports the user to use it when using external power supply. After docking this sorting board with the Handler interface, the internal Handler of TH2518 instrument will work on the internal power supply regardless of whether the Handler power supply of the instrument is selected internally or externally. Users only need to connect the external power supply and external ground to EXT-VCC/EXT-GND at the corresponding positions on the terminal block of the option board.

8.2 Scanning Plug-in Board Pin Interface Description

The front top view of the scanning plugboard bullhorn connector is shown below:

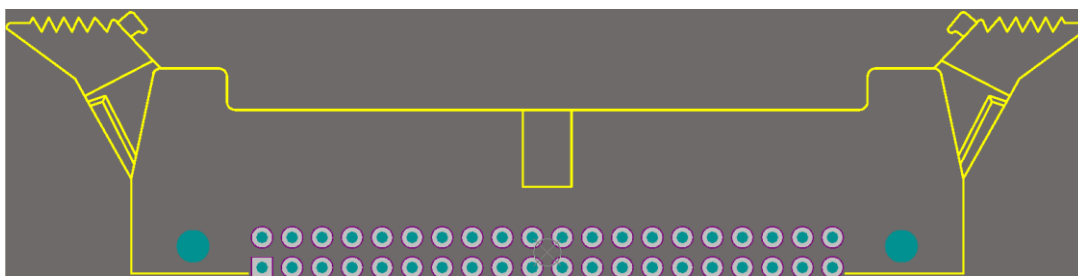

The pin descriptions corresponding to the above figure are shown in the table below:

G	D1	D2	D3	D4	D5	D6	D7	D8	G	G	D9	D10	D11	D12	D13	D14	D15	D16	G
G	S1	S2	S3	S4	S5	S6	S7	S8	G	G	S9	S10	S11	S12	S13	S14	S15	S16	G

G: GND

D: Current drive terminal

S: Voltage sampling terminal

Specific connections can be found in section 3.5.1 Junction Box (Accessories).

Chapter 9 Packages & Warranty

9.1 Packages

Instruments should be shipped with the following items:

serial number	name (of a thing)	quantities
1	TH2518 Series Instrument Mainframe	1 unit
2	TH2518-MS Test Scanner Board	1 piece
3	TH26050A four-terminal test cable	1 payment
4	Three-wire power cord	1 root
5	Flat cable (40 cores)	1 root
6	1A Fuse	2 pieces
7	Command manual	1 copy
8	Certificate of Conformity	1 sheet
9	Test Report	1 copy
10	warranty card	1 sheet

After receiving the instrument, the user should check the above contents after opening the box, if missing, please contact our company or operation department immediately.

9.2 Option

TH26056 Junction Box

TH2518-01 Channel Comparison Sorting Board

9.3 Symbol

The following symbols are on the panel or nameplate of each instrument.

- 1) Manufacturer's name or trademark.
- 2) Product name and model number.
- 3) Product number and year of manufacture.
- 4) Manufacture of measuring instruments license mark and number.
- 5) Test end symbol.

9.4 Packaging

Measuring instruments should generally be packed in plastic bags together with accessories, spare parts, Command manuals and product certificates of conformity in a sturdy packing box that is dust, shock and moisture proof.

9.5 Transportation

The gauge should be carefully and gently placed, protected from moisture and showers during transportation.

9.6 Storage

The measuring instrument is stored in a ventilated room with an ambient temperature of 5°C~40°C and a relative humidity of not more than 85%, and the air should not contain harmful impurities that corrode the measuring instrument.

9.7 Warranty

Warranty period: The warranty period of two years shall be calculated from the date of shipment of the instrument purchased from the Company by the user unit, or from the date of shipment of the instrument purchased from the management department. Warranty should be issued by the instrument warranty card. During the warranty period, if the instrument is damaged due to improper operation by the user, the maintenance cost shall be borne by the user. The company is responsible for the lifetime maintenance of the instrument.

The maintenance of this instrument requires professional and technical personnel to carry out maintenance; maintenance, please do not replace the internal components of the instrument without authorization; after the maintenance of the instrument, it must be re-metered and calibrated, so as not to affect the accuracy of the test. Due to the user blind maintenance, replacement of instrument components caused by damage to the instrument is not covered by the warranty, the user should bear the maintenance costs.

Chapter 10 Appendix

10.1 Firmware Upgrade

Some parts of this manual apply to software version V1.4.4 or later.

10.1.1 TH2518 Upgrade

- 1) Copy the file TH2518.sec to a USB flash drive and insert it into the TH2518 instrument USB flash drive port.
- 2) Turn on the TH2518, enter the <System Setup> interface, set the "Password" setting item to "Lock System", and the system lock password to "2518". Turn off the instrument.
- 3) Power on the computer again and enter the upgrade password "25182014" to complete the upgrade.
- 4) After completing the upgrade, enter the password "2518" to enter the <Measurement Display> page.
- 5) Enter the <System Settings> interface, set the "Password" setting to "OFF", and enter the password "2518".

10.1.2 TH2518A Upgrade

- 1) Copy the file TH2518A.sec to a USB flash drive and insert it into the TH2518 instrument USB flash drive port.
- 2) Turn on the TH2518A, enter the <System Setup> interface, set the "Password" setting item to "Lock System", and the system lock password to "2518". Turn off the instrument.
- 3) Power on the computer again and enter the upgrade password "25182014" to complete the upgrade.
- 4) After completing the upgrade, enter the password "2518" to enter the <Measurement Display> page.
- 5) Enter the <System Settings> interface, set the "Password" setting to "OFF", and enter the password "2518".

10.1.3 Upgrade Matters

If the upgrade prompts "Load *.SEC File failed!", please format the USB flash disk and put only the upgrade file corresponding to the instrument model on the USB flash disk.

When formatting, make the following selections:

File system: FAT32 (default)

Allocation unit size: default configuration size

Formatting Options: Quick Format

10.2 Manual Change Commands

- 1) Version: V1.1.0
Date: 2019.12.23
Note: Large version of the Commands format changed.
- 2) Version: V1.1.1 (for program version 1.3.2 and above, same below)

Date: 2020.03.10

Description: MODBUS auto return format corresponds to the program.

3) Version: V1.1.2

Date: 2020.03.30

Description: Replaces the boot page image.

4) Version: V1.1.3

Date: 2020.11.23

Description: Modifies the PT100 and PT500 temperature ranges.

Modifies TH2518 command set section and typography.

5) Version: V1.1.4

Date: 2021.04.25

Description: Modifies the picture of the system setup interface and add the description of bottom saving and bottom valve ratio.

6) Version: V1.1.5

Date: 2021.10.11

Description: Modifies the error in the MODBUS command description section.

7) Version: V1.1.6

Date: 2022.01.07

Description: Modifies the SCPI command description section error.

Modifies the system settings image to add the next page

The PROTO and FetcAuto locations are relocated to the next page of System Setup. the PROTO parameter name is changed to 232 Protocol.